



322003 (F02H2AW02S)

Bain-marie on cupboard, two wells (2 GN container capacity) with wheels, overshelf with LED lights and two stainless steel tray sliders, H=900mm (Nordic)

Main Features

- Electronic overheating protection.
- Perfect compact design makes it ideal for space saving environments.
- CB and CE certified by a third party notified body.
- Soft closing doors on operator side.
- Underneath ambient cupboard with doors ideal for extra storage.
- Available options with online configurator: colors, tray sliders, overshelves, feet/wheels with desired diameter, height 750mm for kids.
- Overshelf equipped with LED lights.
- Optional plinth can be installed to cover the feet or the wheels.
- AISI 304 Tray slider in flush mounted stainless steel is installed on long sides and they can also be folded down to facilitate passage of the units through doorways.
- Ideal for servery lines without an operator.
- Unit mounted on 125 mm wheels 2 swivel and 2 with brakes.
- Stylish A type overshelf designed for extra increased visibility on the surface for charming food display.
- Curved glass.
- Designed to serve the food in gastronorm containers.
- Suitable for GN 1/1 containers with a maximum height of 200 mm.
- Precise temperature control and setting at 0,1°C .
- As standard the product comes with digitally controlled thermostat which is in line of HACCP norms and provides visual alarm as a warning of the increasing or decreasing temperatures.
- It is possible to transform one of the GNs to soup dispenser with the available accessory.
- Available drop-in dimensions: 2, 3, 4 GN.
- Wells bottom are inclined to guarantee full well drainage.
- Food introduced at the correct temperature maintains its core temperature according to Afnor Standards.
- Available dimensions: 2, 3, 4 GN.
- Thanks to the sleek, minimalist glass structure, food and dust does not get trapped and the cleaning is made easier.
- Designed to work with both hot and cold water.



Construction

- Heating elements connected to the well bottom include safety thermostat.
- IPx4 water protection.
- Overshelf in complete AISI 304.
- Top in AISI 304.
- Sturdy construction with laminated panelings on 4 sides.
- Well in 304 AISI stainless steel with rounded corners to facilitate cleaning operations. The well is also equipped with a drain hole.
- Electronic control with temperature display.

Sustainability

- Etched foil heating elements to maximize heat transmission for reduced warm-up times.
- 19mm thick rock wool isolated with galvanize sheet guarantees excellent well insulation to reduce energy dispersion.
- Equipped with separated GN 1/1 wells to minimize water and electricity usage allowing to operate only the needed wells. Each well can be switched on/off independently.

Optional Accessories

PNC Code	Description
Feet, wheels and ramps	
800002	Kit 4 height adjustable flanged feet, Marine
Kicking strips	
800005	Kicking strip for 2 GN units (only for Bain-Marie with separated wells)

Recommended Detergents

PNC Code	Description
OS2881	S01 STAINLESS STEEL SURFACE POLISHER; 6 BOTTLES X 750ML C/T
OS2883	S03 ALCOHOL BASE DETERGENT; 6 BOTTLES X 750ML; ADR&IMDG&IATA Limited Quantity
OS2884	S04 GLASSES & HARD SURFACES CLEANERS; 6 BOTTLES X 750ML
OS3257	S05 - MULTIPURPOSE DEGREASER; 6PCS X 750ML; ADR&IMDG Limited Quantity



Technical specifications

Electric

Supply voltage:	220-240 V/1N ph/50/60 Hz
Electrical power max.:	2.04 kW

Water:

Water drain outlet size:	3/4"
--------------------------	------

Key Information:

N° of doors:	1
External dimensions, Width:	800 mm
External dimensions, Depth:	1180 mm
External dimensions, Height:	1304 mm
Net weight:	97.5 kg
Shipping height:	1334 mm
Shipping width:	840 mm
Shipping depth:	899 mm
Shipping volume:	1.01 m ³
Set temperature:	+85 / +95 °C

Sustainability

Noise level:	45 dBA
--------------	--------

Front

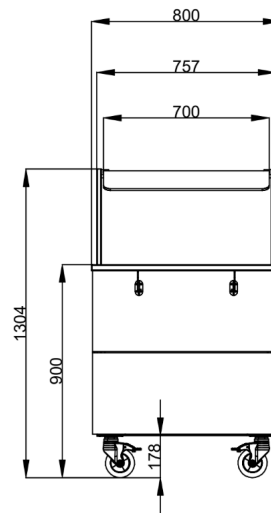

Side

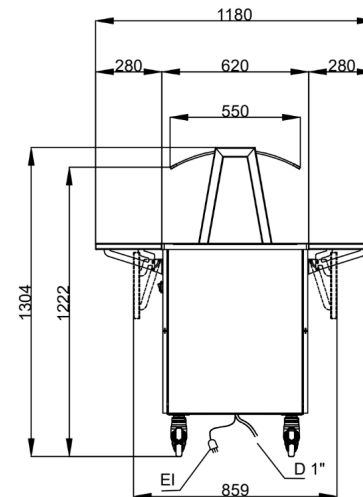

Top

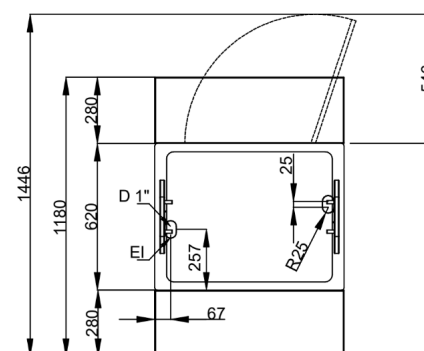

D = Drain

EI = Electrical inlet (power)



Find out more:
ISO Certificates
Electrolux Professional Recognitions

The company reserves the right to make modifications to the products without prior notice. All information correct at time of printing.

2026/05/12

3/3