



322066 (F14C2KW02S)

Refrigerated stainless steel surface on cupboard (2 GN container capacity) with wheels, overshelf with LED lights and two stainless steel tray sliders, H=750mm (Nordic)

Main Features

- Perfect compact design makes it ideal for space saving environments.
- CB and CE certified by a third party notified body.
- Soft closing doors on operator side.
- Underneath ambient cupboard with doors ideal for extra storage.
- Available options with online configurator: colors, tray sliders, overshelves, feet/wheels with desired diameter, height 750mm for kids.
- Overshelf equipped with LED lights.
- Optional plinth can be installed to cover the feet or the wheels.
- AISI 304 Tray slider in flush mounted stainless steel is installed on long sides and they can also be folded down to facilitate passage of the units through doorways.
- Ideal for servery lines without an operator.
- Unit mounted on 125 mm wheels 2 swivel and 2 with brakes.
- Stylish A type overshelf designed for extra increased visibility on the surface for charming food display.
- Curved glass.
- Precise temperature control and setting at 0,1°C .
- As standard the product comes with digitally controlled thermostat which is in line of HACCP norms and provides visual alarm as a warning of the increasing or decreasing temperatures.
- Food introduced at the correct temperature maintains its core temperature according to Afnor Standards.
- Automatic defrosting guarantees evaporators clearance and efficient well cooling.
- Designed to serve the food on plates .
- When the temperature of the surface is cooled down to below 0 °C, the humidity in the air forms ice on the surface. If there is air circulation in the ambient, there is condensation on the surface instead of ice.
- Equipped with a drain hole to easily discharge top condensation.
- Surface mat is available as an accessory.
- Available dimensions: 2, 3, 4 GN.
- Thanks to the sleek, minimalist glass structure, food and dust does not get trapped and the cleaning is made easier.



Construction

- Well bottom is inclined to facilitate water drainage.
- Overshelf in complete AISI 304.
- Top in AISI 304.
- Sturdy construction with laminated panelings on 4 sides.
- Well in 304 AISI stainless steel with rounded corners to facilitate cleaning operations. The well is also equipped with a drain hole.
- Electronic control with temperature display.
- IPx2 water protection.
- The bottom is equipped with copper tubes to ensure proper cooling, with this system the air touches the cold surface and gets cooled.
- Pressed Stainless steel top 30mm deep with rounded edges and drain hole for easier cleaning.

Sustainability

- Hydrocarbon refrigerant gas R290 for the lowest environmental impact (GWP=3) - CFC and HCFC free.
- High-density expanded polyurethane foam with cyclopentane guarantees excellent well insulation to reduce energy dispersion.

Optional Accessories

| PNC Code | Description |
|-------------------------------|--|
| Feet, wheels and ramps | |
| 800002 | Kit 4 height adjustable flanged feet, Marine |
| Kicking strips | |
| 800004 | Kicking strip for 2 GN units (not for Bain-Marie with separated wells) |

Recommended Detergents

| PNC Code | Description |
|----------|---|
| OS2881 | S01 STAINLESS STEEL SURFACE POLISHER; 6 BOTTLES X 750ML C/T |
| OS2883 | S03 ALCOHOL BASE DETERGENT; 6 BOTTLES X 750ML; ADR&IMDG&IATA Limited Quantity |
| OS2884 | S04 GLASSES & HARD SURFACES CLEANERS; 6 BOTTLES X 750ML |
| OS3257 | S05 - MULTIPURPOSE DEGREASER; 6PCS X 750ML; ADR&IMDG Limited Quantity |



Technical specifications

Electric

| | |
|------------------------|-----------------------|
| Supply voltage: | 220-240 V/1N ph/50 Hz |
| Electrical power max.: | 0.49 kW |

Water:

| | |
|--------------------------|------|
| Water drain outlet size: | 3/4" |
|--------------------------|------|

Key Information:

| | |
|------------------------------|---------------------|
| N° of doors: | 1 |
| External dimensions, Width: | 770 mm |
| External dimensions, Depth: | 1180 mm |
| External dimensions, Height: | 1154 mm |
| Net weight: | 102.5 kg |
| Shipping height: | 1184 mm |
| Shipping width: | 810 mm |
| Shipping depth: | 899 mm |
| Shipping volume: | 0.86 m ³ |
| Set temperature: | -10 / 0 °C |
| Top temperature: | -10 / 0 °C |

Sustainability

| | |
|--------------|--------|
| Noise level: | 59 dBA |
|--------------|--------|

Front

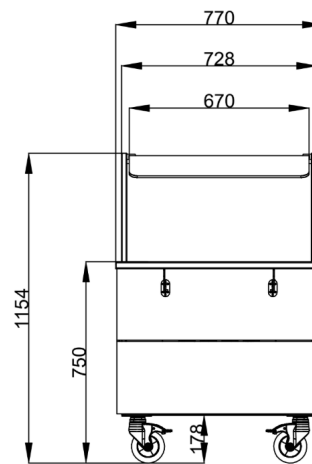

Side

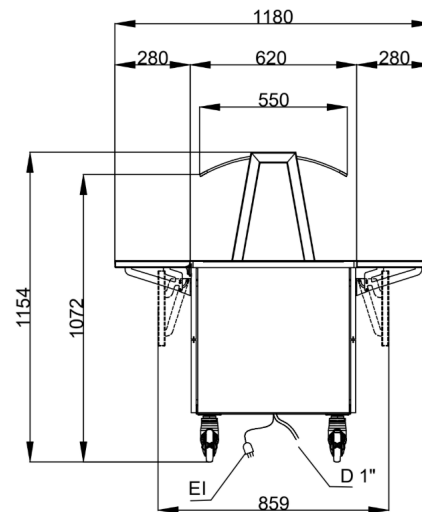

Top

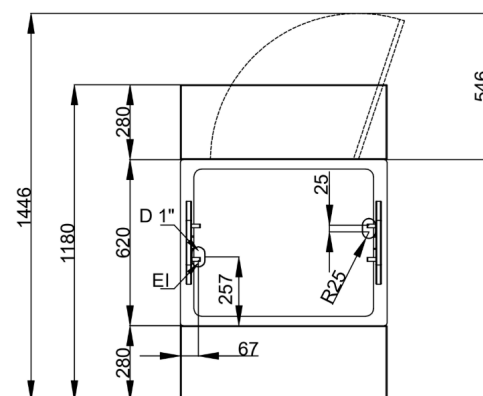

D = Drain

EI = Electrical inlet (power)



Find out more:
ISO Certificates
Electrolux Professional Recognitions

The company reserves the right to make modifications to the products without prior notice. All information correct at time of printing.

2026/05/16

3/3