

**341084 (D21C3)**

Drop-in refrigerated quartz surface (3 GN container capacity)

Main Features

- CB and CE certified by a third party notified body.
- Designed to be positioned in flush installation providing improved cleanability and suitable for modern design installations.
- Precise temperature control and setting at 0,1°C .
- As standard the product comes with digitally controlled thermostat which is in line of HACCP norms and provides visual alarm as a warning of the increasing or decreasing temperatures.
- Available drop-in dimensions: 1, 2, 3, 4, 5, 6 GN.
- Food introduced at the correct temperature maintains its core temperature according to Afnor Standards.
- Automatic defrosting guarantees evaporators clearance and efficient well cooling.
- Remote version is available.
- Designed to serve the food on plates .
- Equipped with a drain hole to easily discharge top condensation.
- It comes with stylish white coloured quartz top and stainless steel framed that makes it ideal to serve cold dishes in an elegant way.

Construction

- Electronic control with temperature display.
- IPx2 water protection.
- The bottom is equipped with copper tubes to ensure proper cooling, with this system the air touches the cold surface and gets cooled.
- AISI 304 Stainless steel frame with rounded corners to facilitate cleaning operations.
- White quartz surface (other quartz colors are available on request).

Sustainability

- Hydrocarbon refrigerant gas R290 for the lowest environmental impact (GWP=3) - CFC and HCFC free.
- High-density expanded polyurethane foam with cyclopentane guarantees excellent well insulation to reduce energy dispersion.



Recommended Detergents

PNC Code	Description
OS2881	S01 STAINLESS STEEL SURFACE POLISHER; 6 BOTTLES X 750ML C/T
OS2883	S03 ALCOHOL BASE DETERGENT; 6 BOTTLES X 750ML; ADR&IMDG&IATA Limited Quantity
OS2884	S04 GLASSES & HARD SURFACES CLEANERS; 6 BOTTLES X 750ML
OS3257	S05 - MULTIPURPOSE DEGREASER; 6PCS X 750ML; ADR&IMDG Limited Quantity



Technical specifications

Electric

Supply voltage:	220-240 V/1N ph/50 Hz
Electrical power max.:	0.47 kW

Water:

Drain line size:	1"
Water drain outlet size:	1"

Key Information:

External dimensions, Width:	1100 mm
External dimensions, Depth:	620 mm
External dimensions, Height:	380 mm
Net weight:	44 kg
Shipping weight (gross):	86 kg
Shipping height:	500 mm
Shipping width:	660 mm
Shipping depth:	1140 mm
Shipping volume:	0.38 m ³
Set temperature:	-10 / 0 °C
Top temperature:	-10 / 0 °C

Refrigeration Data

Refrigerant type:	R290
-------------------	------

Sustainability

Noise level:	59 dBA
--------------	--------

Side

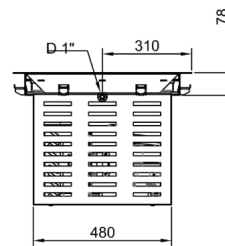

Top

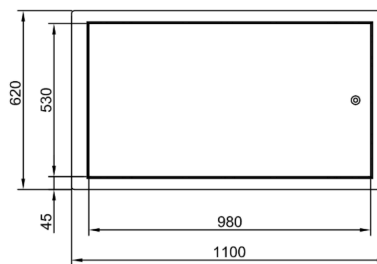

Other

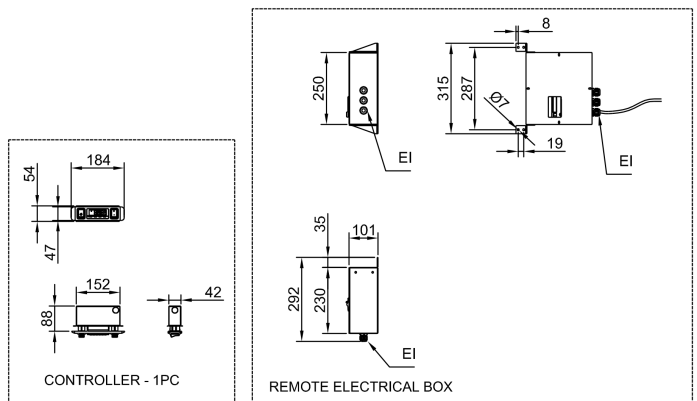

D = Drain

EI = Electrical inlet (power)

ED = Remote electrical connection



Find out more:
ISO Certificates
Electrolux Professional Recognitions

The company reserves the right to make modifications to the products without prior notice. All information correct at time of printing.

2026/05/16

3/4

Technical specifications

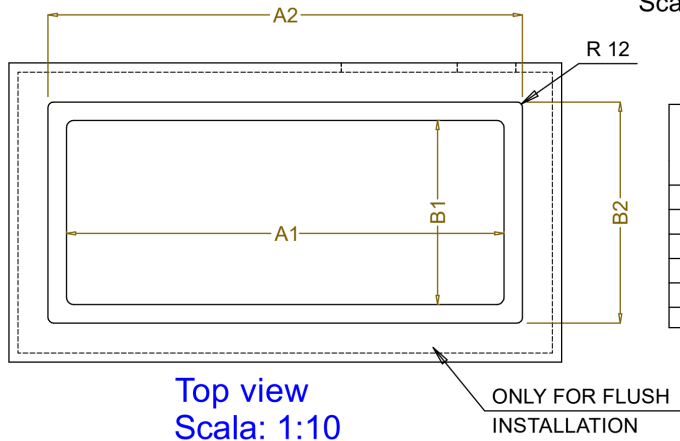
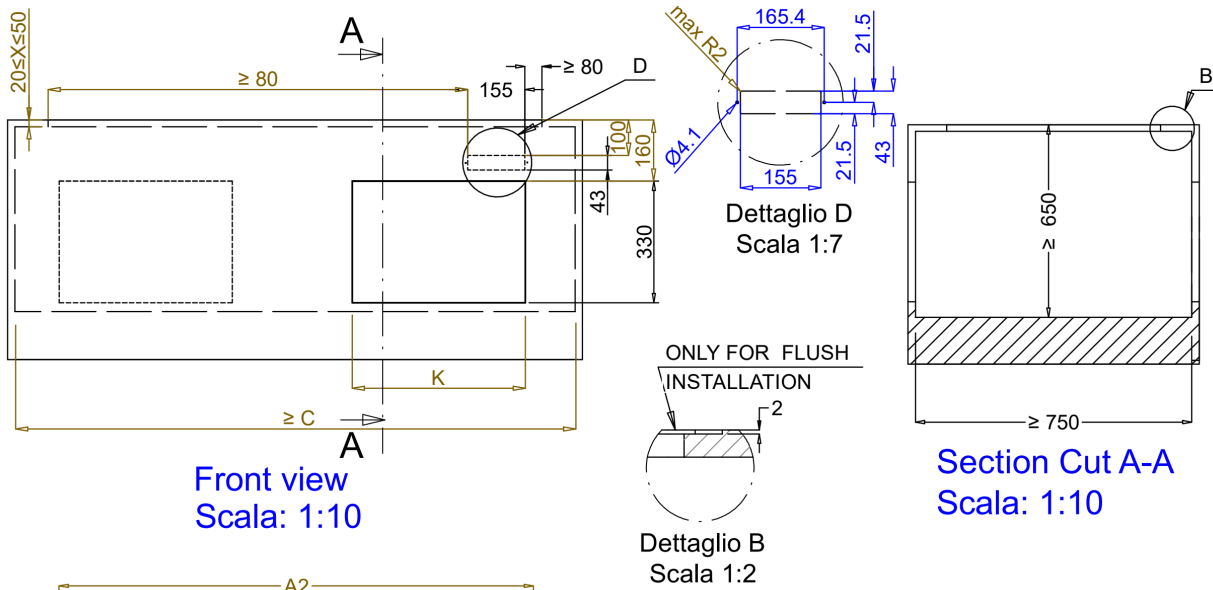

CAPACITY	CUTOUT		LOWERING FOR FLUSH INSTALLATION		C	K
	A1	B1	A2	B2		
1GN	355	560	454	624	535	380
2GN	680		774		855	
3GN	1010		1104		1190	
4GN	1330	1424	1510	470		
5GN	1660	1744	1835			
6GN	1985	2074	2165			

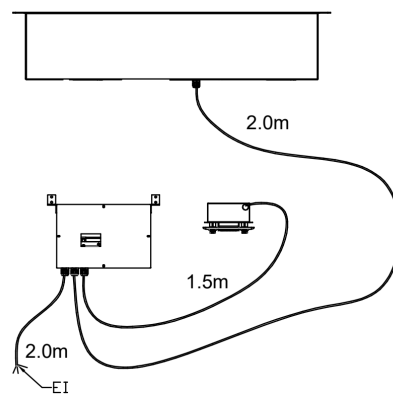
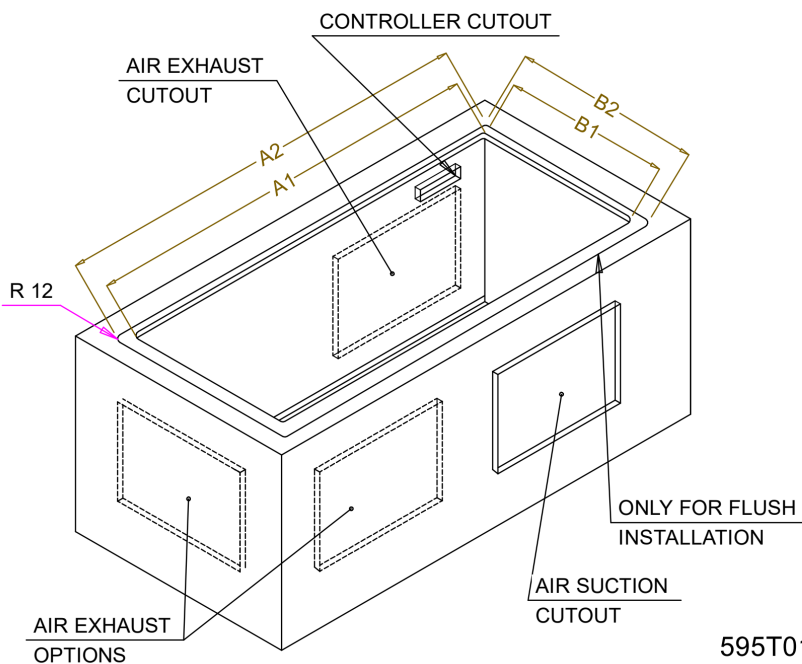

595T01Q00 - COLD QUARTZ SURFACE



Find out more:
ISO Certificates
Electrolux Professional Recognitions

The company reserves the right to make modifications to the products without prior notice. All information correct at time of printing.

2026/05/16

4/4