

**351084 (E2VVADBRZA)**

LiberoPro Point Mobile Counter with 1 refrigerated drawer , suitable for 2 LiberoPro Line appliances with four 1-phase sockets

Main Features

- Compact, lightweight and easy to move.
- Plate holder shelf coupled with tempered glass and lighting for a better visibility from guest side.
- Designed for LiberoPro Duo function for automatic regulation of fan speed according to cooking intensity. Can be activated exclusively with LiberoPro stand alone units.
- LiberoPro Fresh is a low noise air filtration system to absorb efficiently grease particles and bad odours in the working area. It is a 2-stage filtering system with stainless steel fat filters and ceramic activated carbon ones.
- Integrated stainless steel refrigerated drawer with temperature regulation between 0°C and +10°C. No drain required.
- 37 lt refrigerated drawer capacity accepting N° 1 GN1/1 + N° 1 GN 2/4 trays.
- 30 lt neutral drawer - accepting N° 1 GN1/1 - is available as optional accessory.
- Can be combined with up to two tabletop appliances LiberoPro 1PHASE (Plug Type Schuko): flat induction hobs, induction wok, induction griddle.
- Through the user interface with soft touch buttons the operator can: - vary the 4 fan speed; - switch on the LED lighting system of the cooking area; - set the temperature of the refrigerated drawer; - display indications on maintenance operations (e.g. on filters) or any anomalous operating conditions.

Construction

- IPx4 water protection.
- Frontal panel in AISI 304 can be customized requiring a special execution.
- Mounted on 4 swivelling wheels with brakes on the 2 front wheels (on the operator side).
- Heavy duty AISI 304 Stainless steel construction.
- Plug type: IEC/EN 60309-1/2 - 32 amps.
- Side support frames each holding n.2 GN 1/9 containers and n.1 tools holder. All included in the standard delivery and easily removable for better cleanability.
- Grease and odours filters are easily accessible and removable from operator's side for efficient maintenance without any tool.



Included Accessories

PNC Code	Description	Quantity
650190	Carbon filter for Mobile Counter	2
650191	Labyrinth grease filter with stainless steel grid for Mobile Counter	2
650192	Support frame for containers including 2 x 1/9 GN trays and 1 kitchen tool holder for Mobile Counter, left side	1
650193	Support frame for containers including 2 x 1/9 GN trays and 1 kitchen tool holder for Mobile Counter, right side	1

Optional Accessories

PNC Code	Description
Filters	
650190	Carbon filter for Mobile Counter
650191	Labyrinth grease filter with stainless steel grid for Mobile Counter
Other accessories	
650189	Neutral drawer for Mobile Counter
650192	Support frame for containers including 2 x 1/9 GN trays and 1 kitchen tool holder for Mobile Counter, left side
650193	Support frame for containers including 2 x 1/9 GN trays and 1 kitchen tool holder for Mobile Counter, right side
650194	Kitchen tool holder to be inserted into support frame for Mobile Counter
650195	Side paper towel support
651003	Cover in PVC for Mobile Counter 2 modules
Shelves	
650005	Tilting side shelf for Mobile Counter

Recommended Detergents

PNC Code	Description
0S2881	S01 STAINLESS STEEL SURFACE POLISHER; 6 BOTTLES X 750ML C/T
0S2882	S02 Degreaser for ovens and SpeedDelight. Specific for cleaning the cooking chambers of GourmeXpress and SpeeDelight. Active up to a maximum of 50°C Complete with spray bottle Pack of 6 750ml bottles
0S2883	S03 ALCOHOL BASE DETERGENT; 6 BOTTLES X 750ML; ADR&IMDG&IATA Limited Quantity
0S2884	S04 GLASSES & HARD SURFACES CLEANERS; 6 BOTTLES X 750ML



Technical specifications

Electric

Supply voltage:	380-415/380-400 V/3N ph/50/60 Hz
Electrical power max.:	14.5 kW
Plug type:	IEC/EN 60309-1/2
Key Information:	
External dimensions, Width:	1231 mm
External dimensions, Depth:	788 mm
External dimensions, Height:	1284 mm
Net weight:	180 kg
Air Emission:	
Air Flow Rate	710 m ³ / hour
Sustainability	
Refrigerant type:	R600a

Front

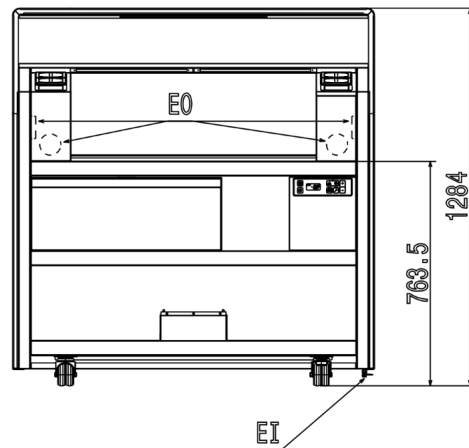

Side

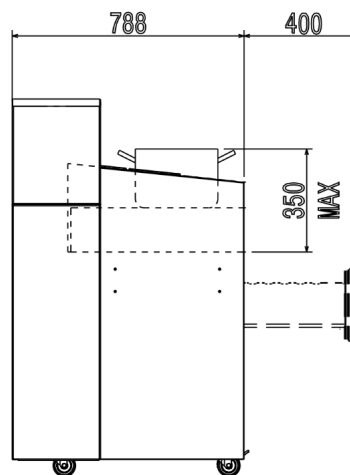

Top

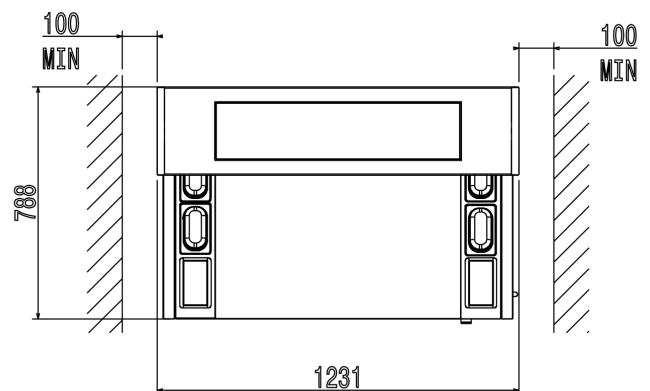

EI = Electrical inlet (power)

EO = Electrical Outlet



Find out more:
ISO Certificates
Electrolux Professional Recognitions

The company reserves the right to make modifications to the products without prior notice. All information correct at time of printing.

03/03/2026

3/3