

371078 (E7FREH2BF0)

7+7-lt electric Fryer free standing with 2 "V" shape wells (external heating elements), 2 baskets and lids included

371141 (E7FREH22FN)

7+7-lt electric Fryer free standing with 2 "V" shape wells (external heating elements), 2 baskets and lids included

Main Features

- All major compartments located in front of unit for ease of maintenance.
- Deep drawn V-Shaped wells.
- IPx4 water protection.
- Overheat protection thermostat as standard on all units.
- Thermostatic regulation of oil temperature up to a maximum of 185 °C.
- Unit to be mounted on height adjustable feet in stainless steel.
- High efficiency infrared heating elements are attached to the outside of the wells.
- Oil drains through a top into a drainage container positioned under the wells.
- Optional portable oil quality monitoring tool (code 9B8081) for efficient oil management

Construction

- Interior of well with rounded corners for ease of cleaning.
- Model has right-angled side edges to allow flush fitting joints between units, eliminating gaps and possible dirt traps.
- One piece pressed 1.5 mm work top in Stainless steel.
- All exterior panels in Stainless Steel with Scotch Brite finishing.

Sustainability

- This model is compliant with Swiss Energy Efficiency Ordinance (730.02).

Included Accessories

PNC Code	Description	Quantity
206350	Door for open base cupboard	2
921608	Basket for 7lt top and free standing fryers	2



Optional Accessories

PNC Code	Description
Bases & base accessories	
206350	Door for open base cupboard
Baskets	
921608	Basket for 7lt top and free standing fryers
Bridge supports	
206138	Support for bridge type installation, 1000mm (only for 371141)
206139	Support for bridge type installation, 1200mm (only for 371078)
Chimney upstands	
206304	Chimney upstand, 800mm (only for 371078)
206400	Chimney grid net, 400mm (700XP/900)
Feet, wheels and ramps	
206135	Kit 4 wheels - 2 swivelling with brake - it is mandatory to install Base support and wheels
206136	Flanged feet kit
206210	Kit 4 feet for concrete installation (not for 900 line free standing grill)
206367	Base support for feet or wheels - 800mm (700/900)
206368	Base support for feet or wheels - 1200mm (700/900)
206369	Base support for feet or wheels - 1600mm (700/900)
206370	Base support for feet or wheels - 2000mm (700/900)
Grease/oil management	
921693	Filter for fryer oil collection basin for 7lt, 14lt, 15lt free standing fryers
Handrails	
206307	Right and left side handrails
206308	Back handrail 800 mm
Installation solutions	
206086	Junction sealing kit
Kicking strips	
206148	Frontal kicking strip for concrete installation, 800mm
206150	Frontal kicking strip for concrete installation, 1000mm
206151	Frontal kicking strip for concrete installation, 1200mm
206152	Frontal kicking strip for concrete installation, 1600mm
206176	Frontal kicking strip, 800mm (not for refr-freezer base)
206177	Frontal kicking strip, 1000mm (not for refr-freezer base)
206178	Frontal kicking strip, 1200mm (not for refr-freezer base)
206179	Frontal kicking strip, 1600mm (not for refr-freezer base)
206249	Pair of side kicking strips
206265	Pair of side kicking strips for concrete installation



PNC Code	Description
Panels	
206374	Rear paneling - 800mm (700/900)
206375	Rear paneling - 1000mm (700/900)
206376	Rear paneling - 1200mm (700/900)
216000	2 side covering panels for free standing appliances



Technical specifications

371078 371141

Electric

Supply voltage:	380-400 V/ 3N ph/50-60 Hz	230 V/3 ph/ 50/60 Hz
Total Watts:	10.8 kW	10.8 kW
Predisposed for:		

Key Information:

Usable well dimensions (width):	240 mm	240 mm
Usable well dimensions (height):	235 mm	235 mm
Usable well dimensions (depth):	380 mm	380 mm
Well capacity:	5.5 lt MIN; 7 lt MAX	5.5 lt MIN; 7 lt MAX
Thermostat Range:	105 °C MIN; 185 °C MAX	105 °C MIN; 185 °C MAX
Net weight:	69 kg	69 kg
Shipping weight:	81 kg	81 kg
Shipping height:	1130 mm	1140 mm
Shipping width:	820 mm	820 mm
Shipping depth:	860 mm	860 mm
Shipping volume:	0.8 m ³	0.8 m ³
Certification group:	EFE72M07	N7FE2

Front

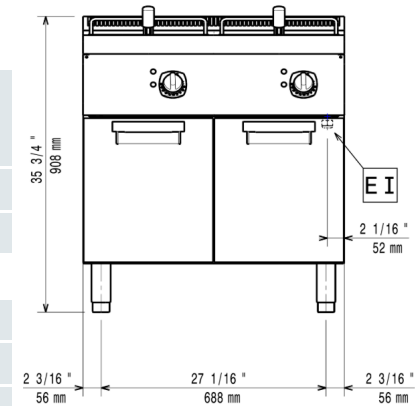

Side

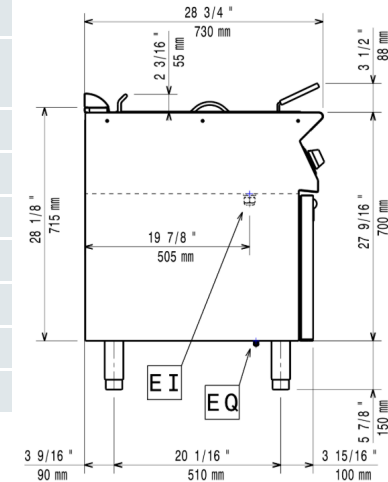

Top

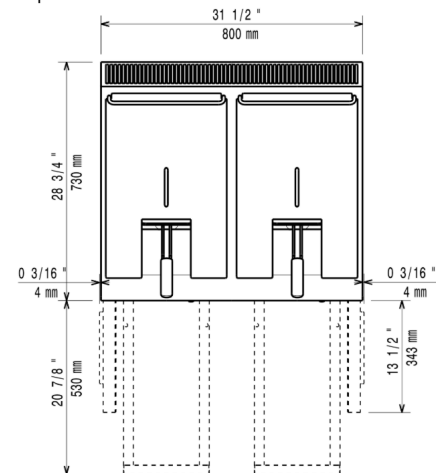

EI = Electrical inlet (power)

EQ = Equipotential screw

DO = Overflow drain pipe



Find out more:
ISO Certificates
Electrolux Professional Recognitions

The company reserves the right to make modifications to the products without prior notice. All information correct at time of printing.

09/03/2026

4/4