

**371116 (E7WTNDN000)**

Ambient WorkTop with closed front, 1/2 module

Main Features

- Heavy duty internal frame in Stainless steel.
- Right angled side edges eliminate gaps and possible dirt traps between units.
- Unit to be installed on other 700 line bases.
- Suitable for countertop installation.

Construction

- One piece pressed 1.5 mm work top in Stainless steel.
- Stainless steel top provides a heavy duty work surface under any load.

Optional Accessories

PNC Code	Description
Bridge supports	
206137	Support for bridge type installation, 800mm
206138	Support for bridge type installation, 1000mm
206139	Support for bridge type installation, 1200mm
206140	Support for bridge type installation, 1400mm
206141	Support for bridge type installation, 1600mm
206154	Support for bridge type installation, 400mm
Chimney upstands	
206303	Chimney upstand, 400mm



PNC Code	Description
Handrails	
206307	Right and left side handrails
206308	Back handrail 800 mm
216046	Frontal handrail, 400mm
216047	Frontal handrail, 800mm
216049	Frontal handrail, 1200mm
216050	Frontal handrail, 1600mm
216185	Large handrail - portioning shelf, 400mm
216186	Large handrail - portioning shelf, 800mm
Installation solutions	
206086	Junction sealing kit
Panels	
216277	2 side covering panels for top appliances
Shelves	
206183	Half module overshelf
Water taps	
206289	Water column with swivel arm (water column extension not included)
206291	Water column extension for 700 line



Technical specifications

Key Information:

External dimensions, Width:	400 mm
External dimensions, Depth:	730 mm
External dimensions, Height:	250 mm
Net weight:	10 kg

Front

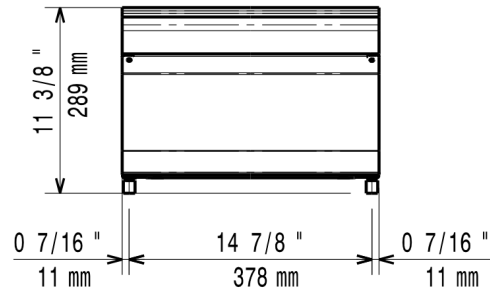

Side

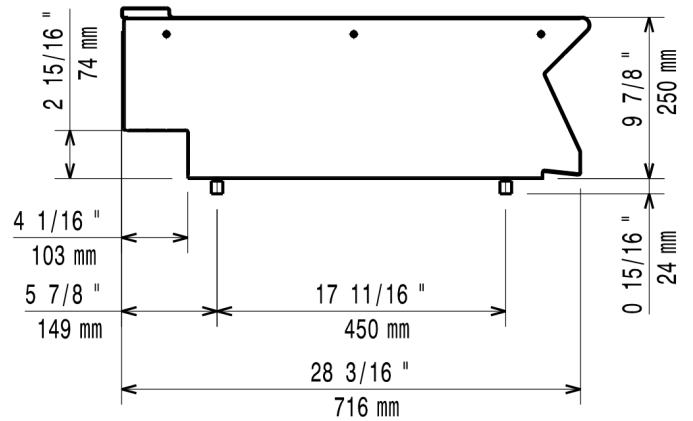

Top

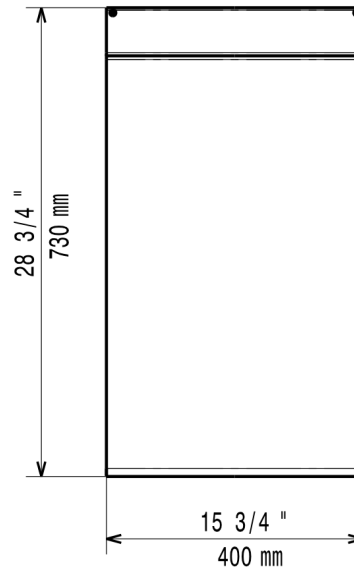

Find out more:
[ISO Certificates](#)
[Electrolux Professional Recognitions](#)

The company reserves the right to make modifications to the products without prior notice. All information correct at time of printing.

24/02/2026

3/3