

371150 (E7ECMH4QE5)

4-Hot Square Plate (2,6 kW each) electric Range on electric Oven (6 kW) - marine

Main Features

- Base compartment consists of an electric standard oven with thick oven door for heat insulation, positioned beneath the base plate.
- IPx4 water protection.
- The four 2.6kW cast-iron square plates are hermtically sealed to the one-piece top.
- The special design of the control knob system guarantees against water infiltration.
- Electric oven to have separate thermostats for top and bottom heating elements.
- Stainless steel oven chamber with 3 levels of runners to accomodate 2/1 GN shelves (2 steam pans).
- Ribbed enamelled steel oven base plate.
- Oven thermostat adjustable from 100 °C to 300 °C.

Construction

- Model has right-angled side edges to allow flush fitting joints between units, eliminating gaps and possible dirt traps.
- One piece pressed 1.5 mm work top in Stainless steel.
- All exterior panels in Stainless Steel with Scotch Brite finishing.

Included Accessories

PNC Code	Description	Quantity
164250	GN2/1 chrome grid for static oven	1



Optional Accessories

PNC Code	Description
Baskets	
921611	Full size basket (220x350x240) for pasta cookers - 700XP and EMPower
Burner grids, plates, supports	
206168	2 cast iron plate bars for electric cooking top
Chimney upstands	
206400	Chimney grid net, 400mm (700XP/900)
Containers, trays and grids	
164250	GN2/1 chrome grid for static oven
Feet, wheels and ramps	
206135	Kit 4 wheels - 2 swivelling with brake - it is mandatory to install Base support and wheels
206136	Flanged feet kit
206210	Kit 4 feet for concrete installation (not for 900 line free standing grill)
206367	Base support for feet or wheels - 800mm (700/900)
206368	Base support for feet or wheels - 1200mm (700/900)
206369	Base support for feet or wheels - 1600mm (700/900)
206370	Base support for feet or wheels - 2000mm (700/900)
Handrails	
206307	Right and left side handrails
206308	Back handrail 800 mm
216047	Frontal handrail, 800mm
216049	Frontal handrail, 1200mm
216050	Frontal handrail, 1600mm
216186	Large handrail - portioning shelf, 800mm
Installation solutions	
206086	Junction sealing kit
Kicking strips	
206148	Frontal kicking strip for concrete installation, 800mm
206151	Frontal kicking strip for concrete installation, 1200mm
206152	Frontal kicking strip for concrete installation, 1600mm
206176	Frontal kicking strip, 800mm (not for refr-freezer base)
206177	Frontal kicking strip, 1000mm (not for refr-freezer base)
206178	Frontal kicking strip, 1200mm (not for refr-freezer base)
206179	Frontal kicking strip, 1600mm (not for refr-freezer base)
206249	Pair of side kicking strips
206265	Pair of side kicking strips for concrete installation



PNC Code	Description
Panels	
206374	Rear paneling - 800mm (700/900)
206375	Rear paneling - 1000mm (700/900)
206376	Rear paneling - 1200mm (700/900)
216000	2 side covering panels for free standing appliances
Water taps	
206289	Water column with swivel arm (water column extension not included)
206291	Water column extension for 700 line



Technical specifications

Electric

Supply voltage:	400 V/3 ph/50/60 Hz
Electrical power max.:	16.4 kW
Key Information:	
Oven Heat Input:	6 kW
Oven working Temperature:	100 °C MIN; 300 °C MAX
Oven Cavity Dimensions (width):	540 mm
Oven Cavity Dimensions (height):	300 mm
Oven Cavity Dimensions (depth):	650 mm
External dimensions, Width:	800 mm
External dimensions, Depth:	730 mm
External dimensions, Height:	850 mm
Net weight:	80 kg
Certification group:	N7CE1
Front Plates Power:	2.6 - 2.6 kW
Back Plates Power:	2.6 - 2.6 kW
Front Plates dimensions:	230x230 230x230
Back Plates dimensions:	230x230 230x230
Waterproof index:	IPX4

Front

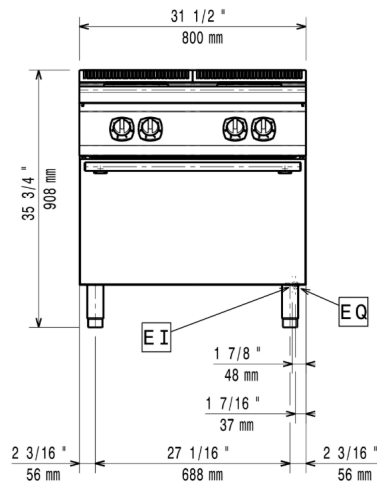

Side

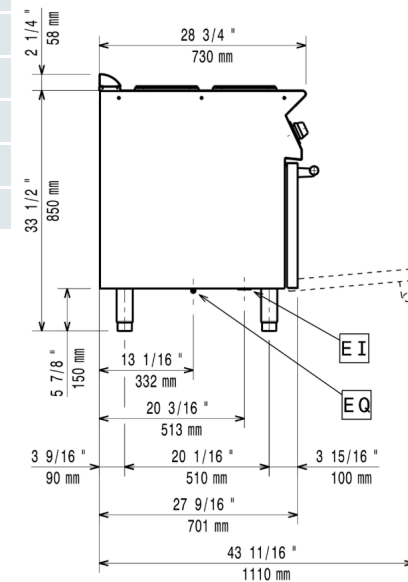

Top

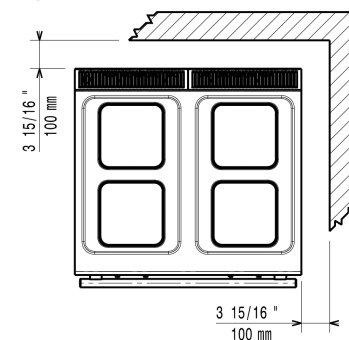

EI = Electrical inlet (power)

EQ = Equipotential screw



Find out more:
ISO Certificates
Electrolux Professional Recognitions

The company reserves the right to make modifications to the products without prior notice. All information correct at time of printing.

24/02/2026

4/4