



371295 (E7TTBECOMIN)

Refrigerated base with 4 drawers, -2/+10° C, automatic evaporation of defrost condense - R290

Main Features

- Adjustable temperature range from -2 °C to +10 °C to suit meat, fish and dairy storage requirements.
- Forced air circulation for rapid cooling and an even temperature distribution.
- Right angled side edges eliminate gaps and possible dirt traps between units.
- Unit can be easily installed below other 700 line top models.
- Defrosting and automatic evaporation of condense drain: the condense is automatically evaporated thanks to the electric resistance in the condense drain container.
- GN compliant
- Designed for modular installation into the cooking block.

Construction

- Access to all components from the front
- Built-in compressor to suit operating conditions.
- Exterior panels in Stainless steel with Scotch Brite finish to meet the highest hygiene standards.
- Unit delivered with 150 mm height adjustable feet in Stainless steel. Feet can be extended up to 250 mm.

Sustainability

- CFC and HCFC free (highly ecological refrigerant type: R290).



Optional Accessories

PNC Code	Description
Bases & base accessories	
206351	2 drawers for refrigerated base
Feet, wheels and ramps	
206136	Flanged feet kit
206210	Kit 4 feet for concrete installation (not for 900 line free standing grill)
206432	Kit 6 wheels - 3 swivelling with brake
Handrails	
206309	Back handrail 1200 mm
Kicking strips	
206151	Frontal kicking strip for concrete installation, 1200mm
206178	Frontal kicking strip, 1200mm (not for refr-freezer base)
206249	Pair of side kicking strips
206265	Pair of side kicking strips for concrete installation
Panels	
206248	2 panels for service duct for single "top on base" installation
206376	Rear paneling - 1200mm (700/900)
216000	2 side covering panels for free standing appliances

Recommended Detergents

PNC Code	Description
OS2292	C41 HI-TEMP RAPID DEGREASER, 1 pack of six 1 lt. bottles (trigger incl.)
OS2881	S01 STAINLESS STEEL SURFACE POLISHER; 6 BOTTLES X 750ML C/T
OS2882	S02 Degreaser for ovens and SpeedDelight. Specific for cleaning the cooking chambers of GourmeXpress and SpeeDelight. Active up to a maximum of 50°C Complete with spray bottle Pack of 6 750ml bottles
OS2883	S03 ALCOHOL BASE DETERGENT; 6 BOTTLES X 750ML; ADR&IMDG&IATA Limited Quantity
OS2884	S04 GLASSES & HARD SURFACES CLEANERS; 6 BOTTLES X 750ML
OS3257	S05 - MULTIPURPOSE DEGREASER; 6PCS X 750ML; ADR&IMDG Limited Quantity



Technical specifications

Electric

Supply voltage:	230 V/1N ph/50 Hz
Electrical power max.:	0.4 kW
Total Watts:	0.4 kW
Plug type:	CE-SCHUKO

Key Information:

External dimensions, Width:	1200 mm
External dimensions, Depth:	700 mm
External dimensions, Height:	600 mm
Net weight:	95 kg
Shipping weight (gross):	112 kg
Shipping height:	800 mm
Shipping width:	820 mm
Shipping depth:	1260 mm
Shipping volume:	0.83 m ³
Gross capacity:	120 liter

Sustainability

Refrigerant weight:	85 g
---------------------	------

Front

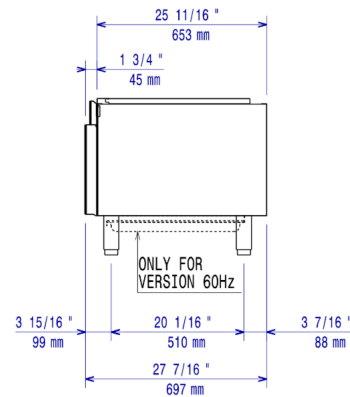

Side

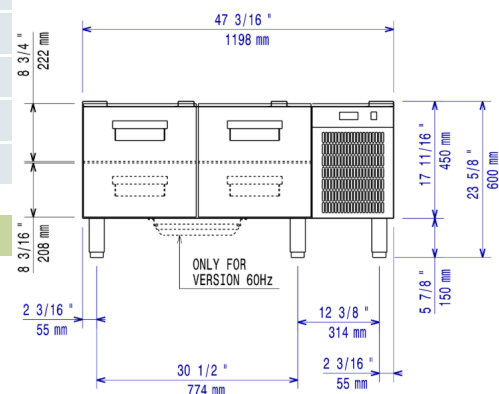

Top

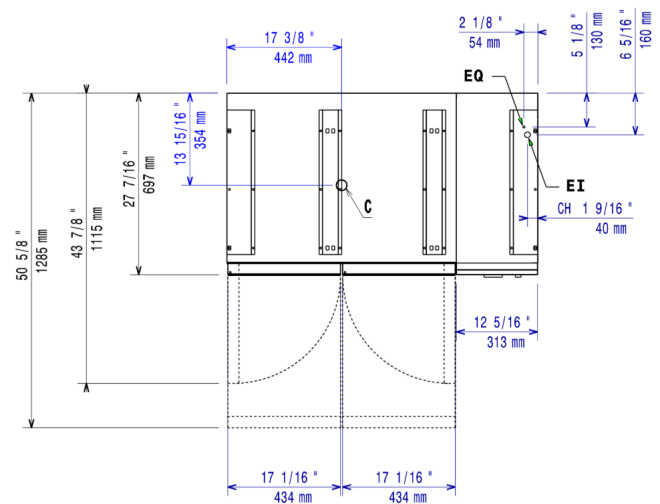

EI = Electrical inlet (power)



Find out more:
ISO Certificates
Electrolux Professional Recognitions

The company reserves the right to make modifications to the products without prior notice. All information correct at time of printing.

2026/06/10

3/3