



**391084 (E9FRGD1JFT0)**

23-lt gas tube Fryer with 1 well, 2 half size baskets and lid included

## Main Features

---

- All major compartments located in front of unit for ease of maintenance.
- Flame failure device on each burner.
- Gas appliance supplied for use with natural or LPG gas, conversion jets supplied as standard.
- Overheat protection thermostat as standard on all units.
- Piezo spark ignition for added safety.
- The special design of the control knob system guarantees against water infiltration.
- Unit delivered with four 50 mm legs in stainless steel as standard (all round Stainless steel kick plates as option).
- Ideal for frying breaded, battered or floured foods in general.
- Tube burners located inside the well avoid food particles burning or spoiling the oil, reducing its usability for fast heat up and quick temperature recovery during the cooking.
- Oil drains through a tap into a drainage container positioned under the well.
- Supplied as standard with 2 half size baskets and 1 right side door for cupboard.
- Thermostatic regulation of oil temperature from 110 °C up to a maximum of 190 °C.
- Optional portable oil quality monitoring tool (code 9B8081) for efficient oil management.

## Construction

---

- Interior of well with rounded corners for ease of cleaning.
- Model has right-angled side edges to allow flush fitting joints between units, eliminating gaps and possible dirt traps.
- One piece pressed 1.5 mm work top in Stainless steel.
- IPX5 water resistance certification.
- All exterior panels in Stainless Steel with Scotch Brite finishing.
- Unit is 930 mm deep to give a larger working surface area.



## Included Accessories

PNC Code	Description	Quantity
206350	Door for open base cupboard	1
927223	2 half size baskets for 15lt OptiOil and 18/23lt fryers	1

## Optional Accessories

PNC Code	Description
----------	-------------

### Bases & base accessories

206350	Door for open base cupboard
--------	-----------------------------

### Baskets

927223	2 half size baskets for 15lt OptiOil and 18/23lt fryers
--------	---

927226	1 full size basket for 15lt OptiOil and 18/23lt fryers
--------	--

### Chimney upstands

206126	Draught diverter, 120 mm diameter
--------	-----------------------------------

206127	Matching ring for flue condenser, 120 mm diameter
--------	---

206303	Chimney upstand, 400mm
--------	------------------------

206310	Flue condenser for 1/2 module, 120 mm diameter
--------	--

### Feet, wheels and ramps

206136	Flanged feet kit
--------	------------------

206210	Kit 4 feet for concrete installation (not for 900 line free standing grill)
--------	---

206372	Base support for feet or wheels (lateral) for 23lt fryers, pasta cookers and refrigerated bases (900XP)
--------	---

### Grease/oil management

200086	Stainless steel oil filter for 18/23lt fryers
--------	---

206209	Extension pipe for oil drainage for fryers
--------	--

927227	Unclogging rod for 23lt fryers drainage pipe
--------	--

### Handrails

206308	Back handrail 800 mm
--------	----------------------

206309	Back handrail 1200 mm
--------	-----------------------

### Installation solutions

206086	Junction sealing kit
--------	----------------------



PNC Code	Description
<b>Kicking strips</b>	
206147	Frontal kicking strip for concrete installation, 400mm
206148	Frontal kicking strip for concrete installation, 800mm
206150	Frontal kicking strip for concrete installation, 1000mm
206151	Frontal kicking strip for concrete installation, 1200mm
206152	Frontal kicking strip for concrete installation, 1600mm
206157	Pair of side kicking strips for concrete installation
206175	Frontal kicking strip, 400mm (not for refr-freezer base)
206176	Frontal kicking strip, 800mm (not for refr-freezer base)
206177	Frontal kicking strip, 1000mm (not for refr-freezer base)
206178	Frontal kicking strip, 1200mm (not for refr-freezer base)
206179	Frontal kicking strip, 1600mm (not for refr-freezer base)
206180	Pair of side kicking strips (not for refr-freezer base)
206203	Frontal kicking strip for 23lt fryers in two parts
<b>Lids</b>	
200171	Lid for oil container for 23 l Fryers
206201	Hygienic lid for 23lt fryers
<b>Other accessories</b>	
927225	Pressure regulator for gas units
<b>Panels</b>	
206181	2 panels for service duct for single installation
206202	2 panels for service duct for back to back installation
206373	Rear paneling - 600mm (700/900XP)
206374	Rear paneling - 800mm (700/900)
206375	Rear paneling - 1000mm (700/900)
206376	Rear paneling - 1200mm (700/900)
216134	2 side covering panels for free standing appliances



# Technical specifications

## Gas

Gas Power:	19 kW
Standard gas delivery:	Natural Gas G20 (20mbar)
Gas Type Option:	LPG; Natural Gas
Gas Inlet:	1/2"
<b>Key Information:</b>	
Usable well dimensions (width):	350 mm
Usable well dimensions (height):	365 mm
Usable well dimensions (depth):	400 mm
Well capacity:	21 lt MIN; 23 lt MAX
Thermostat Range:	110 °C MIN; 190 °C MAX
Net weight:	65 kg
Shipping weight (gross):	74 kg
Shipping height:	1350 mm
Shipping width:	460 mm
Shipping depth:	1020 mm
Shipping volume:	0.63 m <sup>3</sup>
Certification group:	N9FG2

## Front

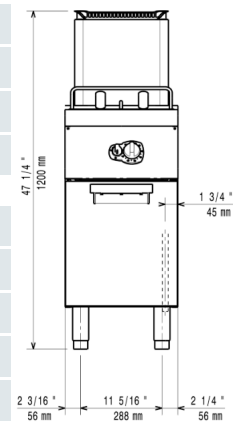

## Side

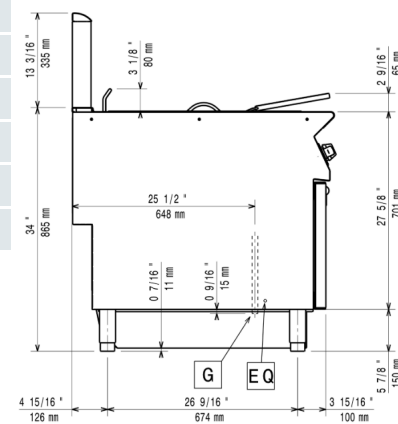

## Top

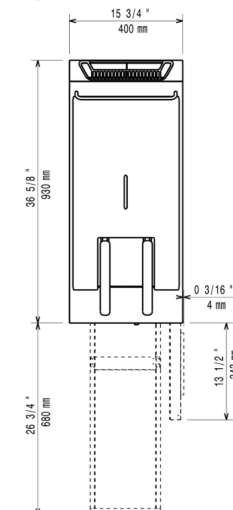

G = Gas connection  
 EQ = Equipotential screw  
 DO = Overflow drain pipe



Find out more:  
 ISO Certificates  
 Electrolux Professional Recognitions

The company reserves the right to make modifications to the products without prior notice. All information correct at time of printing.

2026/05/31