



391302 (E9BRGHDOFW)

80-lt gas tilting Braising Pan with Duomat cooking surface, thermostatic control - Tunisia

Main Features

- Actual cooking temperature setting through adjustable thermostat
- Manual tilting mechanism to facilitate pan emptying.
- Smooth large surfaces, easy access for cleaning.
- The special design of the control knob system guarantees against water infiltration.
- Double-skin well and lid to reduce heat dispersion.
- Lid is double-lined, insulated in 20/10 Stainless steel.
- Energy input controlled by energy regulator.
- Bratt pan ideal for sautéing, poaching, steaming, boiling, stewing and damp cooking.
- Duomat cooking surface allows to perform wet and dry cooking alternatively.
- Working temperature can be set from 80 °C to 300 °C.

Construction

- All pan internal surfaces round and polished for better hygiene.
- Burners in chrome plated steel with flame failure device, optimized combustion and piezo ignition with electronic flame control.
- IPX5 water resistance certification.
- Cooking surface with [i][b]Duomat[/b]/[i] bottom: a 10 mm-thick alloy obtained from the combination of 2 different stainless steels for better thermal stability and corrosion resistance.
- Usable capacity of the well 66 liters.

Sustainability

- Heat-insulated: limited heat radiation and low energy consumption.



Optional Accessories

PNC Code	Description
Chimney upstands	
206132	Draught diverter, 150 mm diameter
206133	Matching ring for flue condenser, 150 mm diameter
206246	Flue condenser for 1 module, 150 mm diameter
206304	Chimney upstand, 800mm
206400	Chimney grid net, 400mm (700XP/900)
Feet, wheels and ramps	
206136	Flanged feet kit
206210	Kit 4 feet for concrete installation (not for 900 line free standing grill)
Gas nozzles	
206464	Kit G.25.3 (NI) gas nozzles for 700 and 900 braising pans
Kicking strips	
206148	Frontal kicking strip for concrete installation, 800mm
206150	Frontal kicking strip for concrete installation, 1000mm
206151	Frontal kicking strip for concrete installation, 1200mm
206152	Frontal kicking strip for concrete installation, 1600mm
206176	Frontal kicking strip, 800mm (not for refr-freezer base)
206177	Frontal kicking strip, 1000mm (not for refr-freezer base)
206178	Frontal kicking strip, 1200mm (not for refr-freezer base)
206179	Frontal kicking strip, 1600mm (not for refr-freezer base)
206180	Pair of side kicking strips (not for refr-freezer base)
Other accessories	
927225	Pressure regulator for gas units
Panels	
206181	2 panels for service duct for single installation
206202	2 panels for service duct for back to back installation
206374	Rear paneling - 800mm (700/900)
206375	Rear paneling - 1000mm (700/900)
206376	Rear paneling - 1200mm (700/900)
Trolleys	
922403	Trolley with lifting & removable tank

Recommended Detergents

PNC Code	Description
0S2292	C41 HI-TEMP RAPID DEGREASER, 1 pack of six 1 lt bottles (trigger incl.)



Technical specifications

Electric

Supply voltage:	220-230 V/1 ph/50 Hz
Total Watts:	0.1 kW

Gas

Gas Power:	21 kW
Standard gas delivery:	Natural Gas G20 (20mbar)
Gas Type Option:	LPG; Natural Gas
Gas Inlet:	1/2"

Key Information:

Cooking Surface Depth:	565 mm
Cooking Surface Width:	680 mm
Cooking Well Height:	180 mm
Well Capacity, Max:	80 lt
Working Temperature MIN:	80 °C
Working Temperature MAX:	300 °C
External dimensions, Width:	800 mm
External dimensions, Depth:	930 mm
External dimensions, Height:	850 mm
Certification group:	N9EBRG

Front

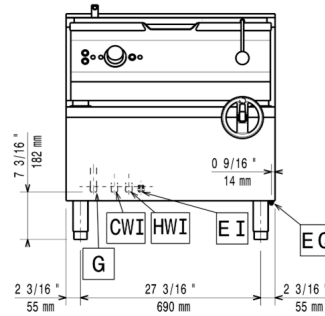

Side

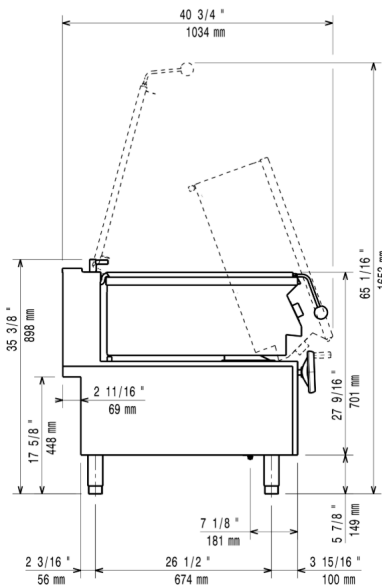

Top

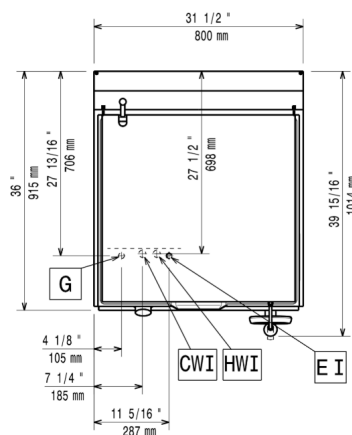

CWI1 = Cold Water inlet 1 (cleaning)

G = Gas connection

EI = Electrical inlet (power)



Find out more:
ISO Certificates
Electrolux Professional Recognitions

The company reserves the right to make modifications to the products without prior notice. All information correct at time of printing.

2026/06/10

3/3