



391450 (E9AAIAAOMCE)
2-Burner (6 kW each) gas Boiling Top with 3mm WorkTop

Main Features

- Flame failure device on each burner protects against gas leakage when accidental extinguishing of the flame occurs.
- Gas appliance supplied for use with natural or LPG gas, conversion jets supplied as standard.
- IPX5 water protection.
- Large sized pan support in cast iron (stainless steel as option) with long center fins to allow the use of the largest down to the smallest pans.
- Protected pilot light
- The special design of the control knob system guarantees against water infiltration.
- Unit to be mounted on open base cupboards, bridging supports or cantilever systems.
- The two 6 kW high efficiency flower flame burners are available in two different sizes to suit high performing cooking requirements of the most demanding customers: - 60 mm burners with power regulation from 1,5 to 6 kW - 100 mm burners with power regulation from 2.2 kW to 10 kW
- Burners with optimized combustion.

Construction

- Model has right-angled side edges to allow flush fitting joints between units, eliminating gaps and possible dirt traps.
- All exterior panels in Stainless Steel with Scotch Brite finishing.
- Unit is 930 mm deep to give a larger working surface area.
- AISI 304 stainless steel worktop, 3mm thick.



Optional Accessories

PNC Code	Description
Bridge supports	
206137	Support for bridge type installation, 800mm
206138	Support for bridge type installation, 1000mm
206139	Support for bridge type installation, 1200mm
206140	Support for bridge type installation, 1400mm
206141	Support for bridge type installation, 1600mm
206154	Support for bridge type installation, 400mm
Burner grids, plates, supports	
206170	Single burner radiant plate for pan support
206171	Single burner smooth plate for direct cooking - fits frontal burners only
206172	Single burner ribbed plate for direct cooking - fits frontal burners only
206298	Stainless steel double grid for 2 burners
206363	Wok pan support for open burners (700/900)
Chimney upstands	
206126	Draught diverter, 120 mm diameter
206127	Matching ring for flue condenser, 120 mm diameter
206303	Chimney upstand, 400mm
206310	Flue condenser for 1/2 module, 120 mm diameter
Gas nozzles	
206384	Kit town gas nozzles (G150) for 900 gas boiling top
Handrails	
206308	Back handrail 800 mm
206309	Back handrail 1200 mm
216044	Side handrail-right/left hand (900XP)
216046	Frontal handrail, 400mm
216047	Frontal handrail, 800mm
216049	Frontal handrail, 1200mm
216050	Frontal handrail, 1600mm
216185	Large handrail - portioning shelf, 400mm
216186	Large handrail - portioning shelf, 800mm
Installation solutions	
206086	Junction sealing kit
Other accessories	
927225	Pressure regulator for gas units
Panels	
216278	2 side covering panels for top appliances



PNC Code	Description
Water taps	
206289	Water column with swivel arm (water column extension not included)
206290	Water column extension for 900 line

Recommended Detergents

PNC Code	Description
OS2292	C41 HI-TEMP RAPID DEGREASER, 1 pack of six 1 lt bottles (trigger incl.)
OS2881	S01 STAINLESS STEEL SURFACE POLISHER; 6 BOTTLES X 750ML C/T
OS2882	S02 Degreaser for ovens and SpeedDelight. Specific for cleaning the cooking chambers of GourmeXpress and SpeeDelight. Active up to a maximum of 50°C Complete with spray bottle Pack of 6 750ml bottles
OS2883	S03 ALCOHOL BASE DETERGENT; 6 BOTTLES X 750ML; ADR&IMDG&IATA Limited Quantity
OS2884	S04 GLASSES & HARD SURFACES CLEANERS; 6 BOTTLES X 750ML
OS3257	S05 - MULTIPURPOSE DEGREASER; 6PCS X 750ML; ADR&IMDG Limited Quantity



Technical specifications

Gas	
Gas Power:	12 kW
Standard gas delivery:	Natural Gas G20 (20mbar)
Gas Type Option:	LPG; Natural Gas
Gas Inlet:	1/2"
Key Information:	
External dimensions, Width:	400 mm
External dimensions, Depth:	930 mm
External dimensions, Height:	250 mm
Net weight:	43 kg
Shipping weight (gross):	42 kg
Shipping height:	520 mm
Shipping width:	460 mm
Shipping depth:	1020 mm
Shipping volume:	0.24 m ³
Front Burners Power:	6 - 0 kW
Back Burners Power:	6 - 0 kW
Certification group:	N9CG
Back Burners Dimension - mm	Ø 60
Front Burners Dimension - mm	Ø 60

Front

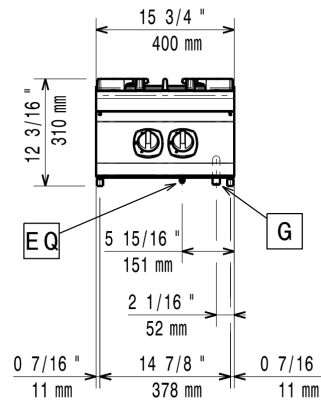

Side

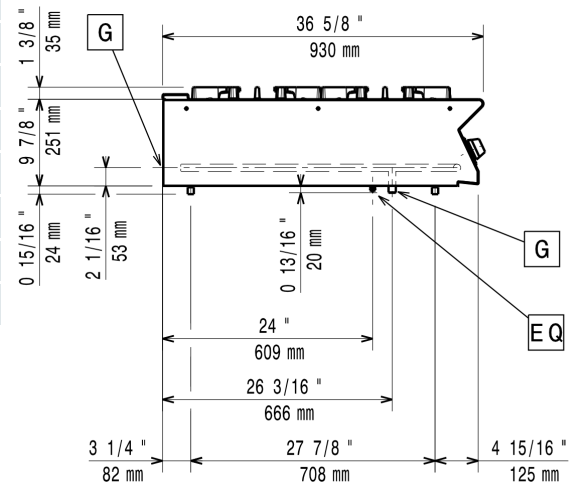

Top

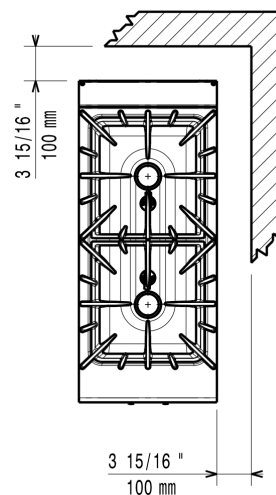

G = Gas connection



Find out more:
ISO Certificates
Electrolux Professional Recognitions

The company reserves the right to make modifications to the products without prior notice. All information correct at time of printing.

2026/06/10

4/4