



600086 (K180S2)

Cutter Mixer 17,5 lt capacity, timer, 2 speeds 1500-3000 rpm. Supplied with microtoothed blade rotor, stainless steel bowl and scraper

Main Features

- Food processor allows fast liquidizing, mixing, mincing, chopping and pastry-making.
- Lid with central opening to add ingredients in mid-cycle.
- Pulse function for coarse chopping.
- Base fixed cover for a better handling.
- Productivity suitable for 100-300 meals per service, up to 8 kg per cycle.
- Angled perforated knives and conical base of the bowl ensure consistent mixing.
- Cover metal frame to ensure seal water tightness to avoid leakage.
- All parts in contact with food are removable without tools and completely dismountable.
- Delivered with: - 17.5 liter stainless steel bowl with max liquid level indication to avoid spillage - micro toothed perforated blade - scraper

Construction

- Asynchronous silent industrial motor for heavy duty and longer life.
- 2 speeds: 1500 and 3000 rpm.
- IP65 touch button control panel.
- Transparent BPA free cover incorporates a magnetic safety system which stops the machine if lid is not properly closed.
- Power: 3600 watts.
- 304 AISI stainless steel bowl with leak resistant spout and handles, easy to manage.
- Scraper with SS handle, easy to dismount
- Cover handle with double safety locking system.
- A safety device requires to press the start button to restart the machine after a power cut



Included Accessories

PNC Code	Description	Quantity
650046	Scraper for K180S and KE180S cutter mixers	1
650047	Microtoothed blade rotor for 17,5 lt cutter mixer	1
650074	Stainless steel bowl for 17,5 lt cutter mixer	1

Optional Accessories

PNC Code	Description
Bowls/tools	
650046	Scraper for K180S and KE180S cutter mixers
650047	Microtoothed blade rotor for 17,5 lt cutter mixer
650074	Stainless steel bowl for 17,5 lt cutter mixer
653119	Smooth blade rotor for 17,5 lt cutter mixer
653120	Serrated blade rotor for 17,5 lt cutter mixer
653539	Serrated blade rotor for meat for 17,5 lt cutter mixer
Trolleys/tables	
653017	Stainless steel mobile stand with 4 wheels (2 fixed and 2 pivoting with brake). Height: 730 mm



Technical specifications

Electric

Supply voltage:	380-415 V/3 ph/50 Hz
Electrical power max.:	3.6 kW
Capacity:	
Performance (up to):	8 kg/Cycle
Capacity:	17.5 liters
Key Information:	
External dimensions, Width:	416 mm
External dimensions, Depth:	680 mm
External dimensions, Height:	603 mm
Shipping weight (gross):	80 kg

Front

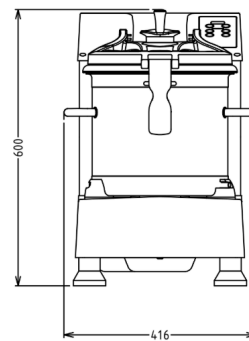

Side

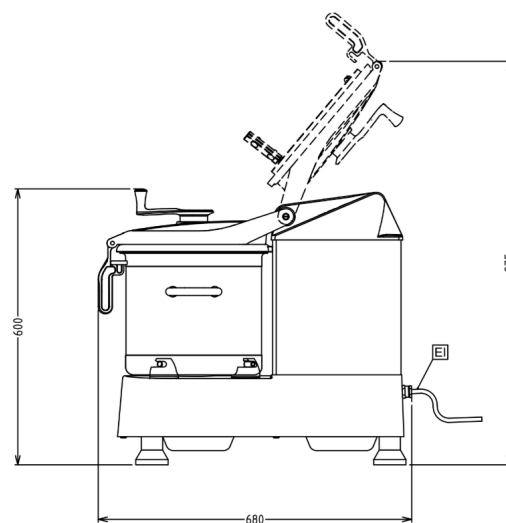

Top

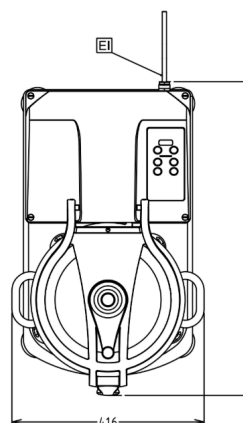

EI = Electrical inlet (power)



Find out more:
ISO Certificates
[Electrolux Professional Recognitions](#)

The company reserves the right to make modifications to the products without prior notice. All information correct at time of printing.

2026/05/11

3/3