

**601302 (T5EFB)**

5 kg stainless steel Vegetable Peeler with abrasive Plate, incorporated filter basket and flat control panel

**Main Features**

- Transparent lid to close the cylinder during peeling operations.
- Dishwasher safe removable parts.
- Easily fits onto the base, with the drive shaft fitting into the center of the plate.
- Integrated built-in filter device, removable for cleaning.
- Peeling time on timer preset to 3 minutes
- Red OFF, green ON buttons.
- Removable stainless steel peeling chamber to contain the abrasive plate which also serves as a container to carry the vegetables.
- Removable water inlet, clipped to the cover, designed to serve as a spray to clean the machine.
- Supplied with an abrasive plate as standard.
- Unit can be placed on a work top.
- Productivity suitable for 30-100 meals per service.

**Construction**

- IP55 waterproof control buttons.
- 1 speed: 305 rpm.
- Transparent BPA free cover.

**Included Accessories**

PNC Code	Description	Quantity
653314	Filter basket for 5 kg vegetable peeler	1
653316	Abrasive plate for 5/8 kg vegetable peeler	1



## Optional Accessories

PNC Code	Description
<b>Baskets</b>	
653315	Drying basket for 5 kg vegetable peeler (only T5E)
<b>Filters</b>	
653314	Filter basket for 5 kg vegetable peeler
<b>Plates</b>	
653316	Abrasive plate for 5/8 kg vegetable peeler
<b>Trolleys/tables</b>	
653496	Stainless steel table for 5 and 8 kg vegetable peelers



# Technical specifications

## Electric

Supply voltage:	220-240 V/1N ph/50/60 Hz
Capacity:	
Performance (up to):	80 kg/hour
Capacity:	5 liters
Key Information:	
External dimensions, Width:	424 mm
External dimensions, Depth:	390 mm
External dimensions, Height:	590 mm
Shipping weight (gross):	24.7 kg

Front

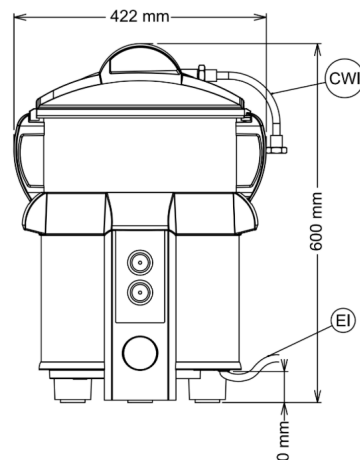

Side

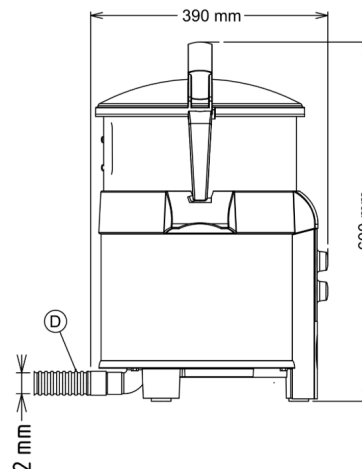

Top

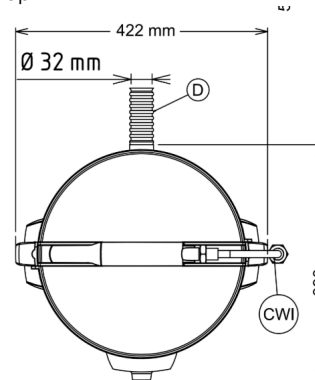

CWI1 = Cold Water inlet 1 (cleaning)

D = Drain

EI = Electrical inlet (power)



Find out more:  
ISO Certificates  
[Electrolux Professional Recognitions](#)

The company reserves the right to make modifications to the products without prior notice. All information correct at time of printing.

2026/05/11

3/3