

**602201 (EMX5_PRO)**

Emix Planetary Mixer black, 5 liters, bowl detection device, electronic variable speed with K type accessory hub. Equipped with stainless steel semi spiral hook, paddle and whisk and highly resistant splashguard - BPA free

Main Features

- Electronic speed variator.
- Removable safety screen activates the raising and lowering of the bowl.
- Safety device will automatically stop the machine when the bowl is lowered.
- Delivered with: - Paddle, Semi-spiral Hook, Wire Whisk and Mixing Bowl for 5,5 lt - K type accessory drive hub (accessories are not included)
- Tools shape and size perfectly adapt to the bowl for uniform mixing of even small quantities.
- Small, compact planetary mixer designed to whisk and mix, providing also good kneading results.
- Maximum capacity (flour, with 60% of hydration) 0,75 kg.
- Bowl detection device allows the mixer to switch on only when the bowl and the solid safety screen are properly installed and positioned together.

Construction

- Power: 500 Watts.
- Variable speed from 40 to 240 rpm (planetary movement), to adjust to the selected tool and mixture hardness.
- Water protected planetary system (IP55 electrical controls, IP34 appliance overall).
- Universal powerful motor with high start-up torque and overload protection.
- Transparent solid safety screen made of Eastman Tritan™ copolyester BPA free, impact resistant and stays clear and durable after several dishwashing cycle.
Eastman&Tritan are trademarks for Eastman Chemical Company.
- Compact design.
- Semi-spiral hook, paddle and wire whisk in stainless steel.
- 304 AISI stainless steel bowl with 2 handles - 5,5 lt capacity.
- Variable speed rotation of the tools from 84 rpm to 500 rpm.



Included Accessories

PNC Code	Description	Quantity
653754	Stainless steel bowl with handles 5 lt	1
653755	Stainless steel semi-spiral hook 5 lt	1
653756	Stainless steel paddle 5 lt	1
653757	Stainless steel whisk 5 lt	1

Optional Accessories

PNC Code	Description
Bowls/tools	
653754	Stainless steel bowl with handles 5 lt
653755	Stainless steel semi-spiral hook 5 lt
653756	Stainless steel paddle 5 lt
653757	Stainless steel whisk 5 lt
Hub accessories	
653043	60 mm meatmincer for attachment type K (12 mm square hub) and 1 disc
653044	3 discs (3-4,5-8 mm) for meatmincer
653296	Pasta kit accessory (lasagne 142,5 mm)
653298	Pasta kit accessory (spaghetti 2 mm)
653300	Pasta kit (lasagne, tagliatelle, tagliolini)



Technical specifications

Electric

Supply voltage:	200-240 V/1N ph/50/60 Hz
Capacity:	
Performance (up to):	0.75 kg/Cycle
Capacity:	5.5 liters
Key Information:	
External dimensions, Width:	280 mm
External dimensions, Depth:	388 mm
External dimensions, Height:	438 mm
Shipping weight:	15 kg
Net weight (kg):	11
Cold water paste:	0.75 kg with Semi spiral hook
Egg whites:	12 with Whisk

Front

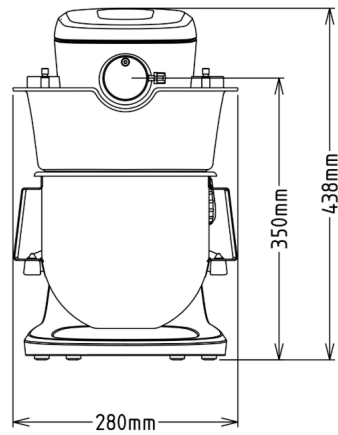

Side

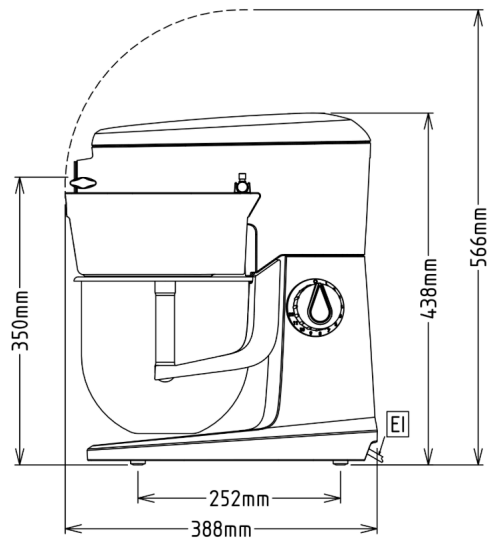

Top

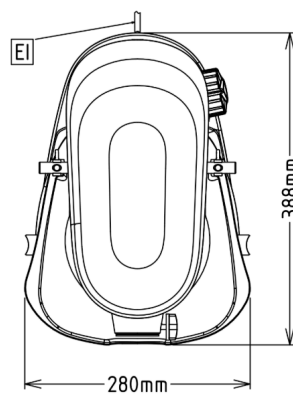

EI = Electrical inlet (power)



Find out more:
[ISO Certificates](#)
[Electrolux Professional Recognitions](#)

The company reserves the right to make modifications to the products without prior notice. All information correct at time of printing.

2026/03/31

3/3