



602339 (EVP60D)

Vacuum Packer, 60 m³/h, sealing bars front/rear 2x620mm, on wheels

Main Features

- Unit pre-arranged to be connected to an inert gas system.
- Vacuum packer on wheels with oil lubricated vacuum pump.
- Vacuum level control through high-precision sensor.
- Pressure chamber made of constant thickness, hydroformed, stainless steel with rounded corners for easy cleaning.
- Sturdy, transparent PMMA (plexiglass) lid with rounded edges; opens automatically at the end of the cycle.
- Control panel, resistant to liquids, humidity, dirt and dust.
- 10 editable user programs (vacuum, extra vacuum, sealing time, gas percentage).
- Automatic warnings if food needs cooling down (hot), failure in the packing process, gas missing, oil change.
- 3 PE filling plates included.
- Equipped with two sealing bars 620 mm each, on front/rear, easily removable for cleaning.
- With device to lift the removable sealing bar.
- Adjustable sealing time 0.1 to 6 seconds.
- Specific pump oil cleaning cycle (H2Out).

Construction

- Entirely constructed in 304 AISI stainless steel.
- Free-standing appliance mounted on 4 castors, 2 with brakes.
- Easily accessible oil drain.
- Chromed aluminium die-cast hinges.

Optional Accessories

PNC Code	Description
Other accessories	
650240	Inclined shelf to vacuum liquids, 300mm (for models with 310mm sealing bar or multiples)
650243	Bluetooth printer for 50x60mm labels, display in English or Italian. To be managed via dedicated app.



Technical specifications

Electric

Supply voltage:	400 V/3N ph/50-60 Hz
Key Information:	
Filling board nr:	3
Gas nozzles:	4+4
External dimensions, Width:	697 mm
External dimensions, Depth:	772 mm
External dimensions, Height:	1034 mm
Net weight (kg):	168.5
Well Capacity:	61 lt
Pump:	60 m ³ /h
Sealing bar position:	Front+Rear
Sealing bar length:	620 mm
Max chamber (chamber + cover) dimensions:	536 x 650 x 200 mm
Chamber working dimensions:	430 x 545 x 130 mm

Front

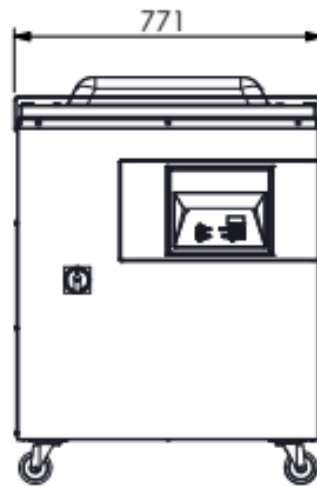

Side

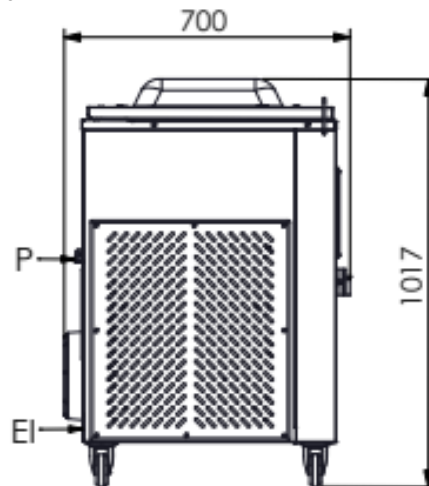

Top

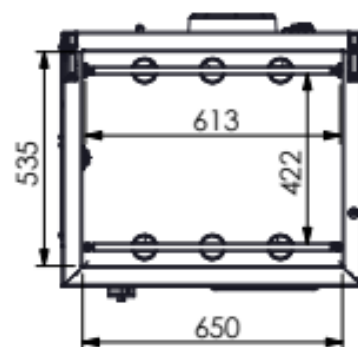

EI = Electrical inlet (power)



Find out more:
[ISO Certificates](#)
[Electrolux Professional Recognitions](#)

The company reserves the right to make modifications to the products without prior notice. All information correct at time of printing.

2026/05/11

2/2