



691340 (PS04R1FRCO2)

1-door prostore Refrigerator 470lt, 0/+10°C, AISI 304, remote, CO2 with valve

What our App can do for you:

- **Stay Connected:** real-time equipment monitoring ensures you're always up to date
- **Smart Connection:** bluetooth integration for fast, reliable control
- **Control at Your Fingertips:** adjustments made easy for seamless operations
- **Effortless Compliance:** download HACCP data in seconds, simplifying food safety management

Main Features

- Low noise level.
- Complies with main international certification bodies and is CE marked.
- Hidden evaporator thus guaranteeing higher storage capacity and less corrosion problems.
- Optimized airflow within the chamber guarantees uniformity of temperature on all grids.
- Model requires only 1 phase 230V/50Hz supply and can be plugged straight into an existing power socket
- Adjustable temperature range from 0°C to +10°C.
- Greater storage space: internal structure with numerous charging positions available to host grids, ensuring higher net capacity.
- Large storage area suitable to contain 520x442 mm grids or shelves to improve net capacity.
- Self closing and on site reversible left/right doors.
- IPX5 frontal water protection.
- Prearranged for remote alarm.
- Tropicalized unit



Construction

- Developed and produced in ISO 9001 and ISO 14001 certified factory.
- Lockable door.
- Inner cell with rounded corners, bottom pressed in only one piece.
- Easy access to the main components for maintenance.
- Stainless steel runners and supports easily disassembled.
- Pressed stainless steel door handle without joints gathering dust and dirt.
- Solenoid valve included.
- Stainless steel AISI 304 external panels (galvanized external back).
- Internal components removable without the use of tools to facilitate cleaning operations.

User Interface & Data Management

- Fully compliant HACCP digital control: when temperature exceeds critical limits, acoustic and visual alarms are activated. Up to two months of event are kept in memory.
- Large digital white-digit display with cabinet temperature display and setting, and possibility to select the desired levels of humidity. Bluetooth technology included allows to keep HACCP historical data and download them through the app.
- Electrolux Professional Fridge Control APP makes the life easier for our customers:
 - Monitor safety of preservation process thanks to HACCP data & alarms for precise control
 - Save time and easy data management having the possibility to send the HACCP information in excel format directly to e-mail address
 - Quick operations: set the cabinet temperature/humidity/turbocooling and set date/hour
- Large digital white-digit display with humidity selection button (3 preset level), cabinet temperature display and setting and turbo frost cycle (to rapidly cool warm loads).
- Connect the product (with accessory) to the OneConnected Platform via Wi Fi or ethernet connection for a seamless remote experience. Real-time monitoring and analytics, alarm management, HACCP data management, APIs, and advanced features keep your fridge fully under control.





A focus on sustainability

Sustainability

- Optical door microswitch to stop the fan once the door is opened, thus minimizing energy waste.
- Interior LED light to save energy and for best internal visibility.
- Removable triple-chamber balloon magnetic gasket to improve insulation and reduce energy consumption and ease of cleaning.
- Frost Watch Control: fully automatic defrost starts only when ice is actually building-up in the evaporator and adapt the defrosting duration to guarantee perfect ice removal while optimizing energy efficiency consumption.
- Insulation thickness: 65 mm of polyurethane injected with ecological foaming gas cyclopentane to ensure effective insulation with minimum energy consumption (thermal conductivity: 0,020 W/m²K).
- CO₂ (R744) is the refrigerant choice that's safe for the environment and delivers outstanding performance.
Eco-Friendly: Zero Ozone Depletion Potential and an ultra-low Global Warming Potential (GWP = 1).
Safe to Use: Non-toxic and non-flammable for peace of mind.
Sustainable: A natural refrigerant that supports a greener, cleaner planet

Certifications & Recognitions



International system for mutual acceptance of test reports and certificates concerning the safety of electrical and electronic components, equipment, and products.



Product assessed by the manufacturer and deemed to meet EU safety, health, and environmental protection requirements.



Find out more:
[ISO Certificates](#)
[Electrolux Professional Recognitions](#)

The company reserves the right to make modifications to the products without prior notice. All information correct at time of printing.

2026/05/21

3/6

Technical specifications

Electric

Supply voltage:	220-240 V/1 ph/50/60 Hz
Electrical power max.:	0.14 kW

Key Information:

Number and type of grids (included):	5 (520x442)
External dimensions, Width:	600 mm
External dimensions, Depth:	700 mm
External dimensions, Depth with Doors Open:	1226 mm
External dimensions, Height:	2040 mm
Number and type of doors:	1 Full
Internal Dimensions, Width:	472 mm
Internal Dimensions, Depth:	582 mm
Internal Dimensions, Height:	1474 mm
Height adjustment:	15/40 mm
Type of external material:	Stainless Steel AISI 304
Type of internal material:	Stainless Steel AISI 304
Number of positions & pitch:	44; 22 mm
Gross capacity:	470 liter

Refrigeration Data

Control type:	Digital
Refrigeration type:	
Operating mode:	Ventilated
Cooling unit:	
Defrost type:	By Air
Suggested refrigeration power:	412 W
Condition at evaporation temperature:	-10 °C
Condition at condensation temperature:	55 °C
Condition at ambient temperature:	43 °C
Connection pipes (remote) - outlet:	8 mm
Connection pipes (remote) - inlet:	8 mm
*Note:	Ref. Power calculated at a linear distance of 15mt (piping).

ISO Certificates

ISO Standards:	ISO 9001; ISO 14001; ISO 45001; ISO 50001
Type reference/certification group:	P60MTNR

Installation drawings

Front

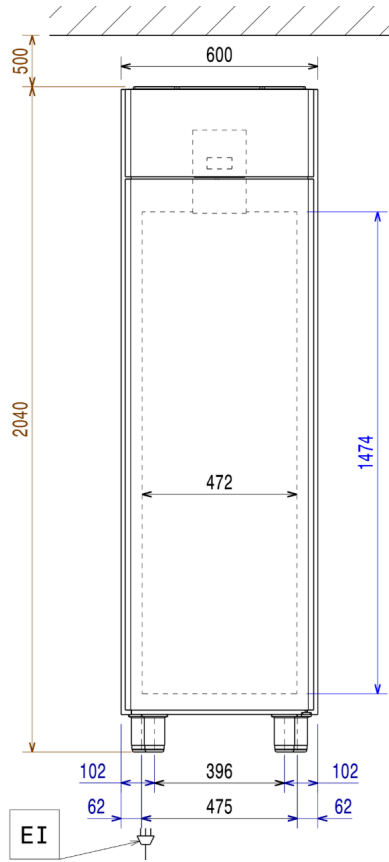

Side

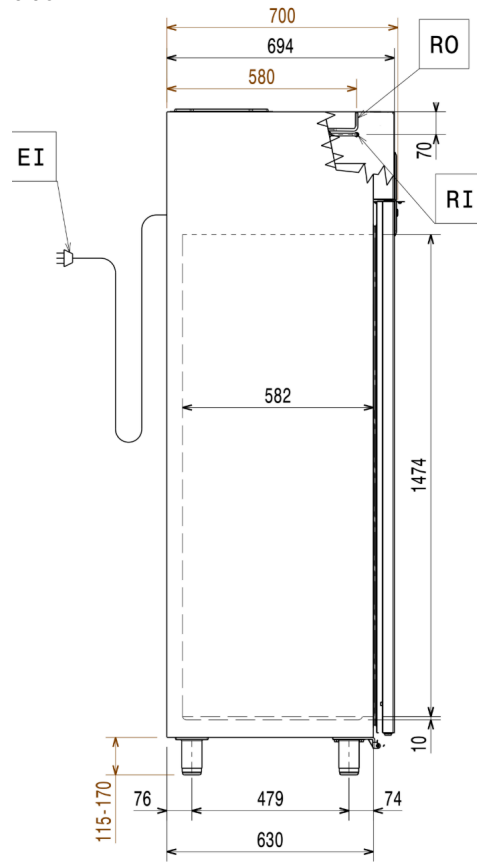

Top

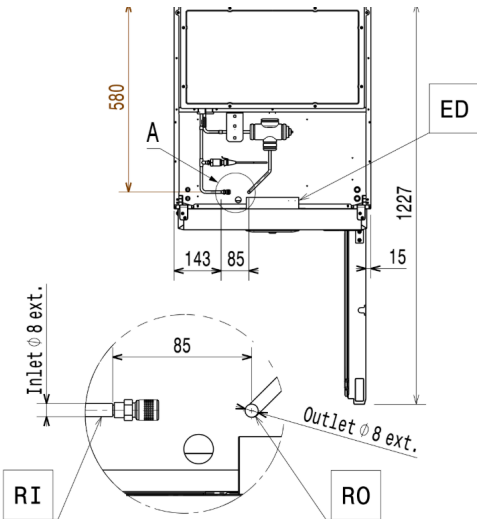

Distances

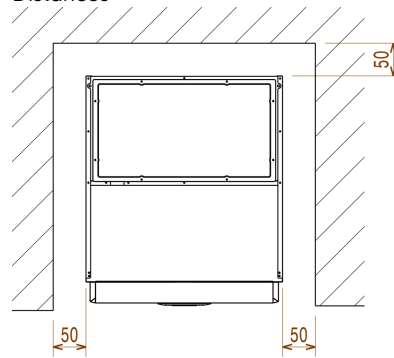

EI = Electrical inlet (power)
RI = Refrigerant Inlet

RO = Refrigerant Outlet

Accessories

Included Accessories

PNC Code	Description	Quantity
880324	Pedal opening for cabinets	1
880335	Pair of runners for 470 and 720lt prostore cabinets	5
880342	Rilsan-coated grid 520x442mm for Prostore 470l	5

Optional Accessories

PNC Code	Description
----------	-------------

Containers, trays and grids

880321	Stainless steel grid (520x442)
880327	Kit pair of runners (marine)
880328	Base frame for 1/1 GN rack for 470lt prostore
880335	Pair of runners for 470 and 720lt prostore cabinets
880342	Rilsan-coated grid 520x442mm for Prostore 470l

Feet, wheels and ramps

880324	Pedal opening for cabinets
880325	Kit 4 feet, height 200mm
880326	Kit of 4 feet-h=67 (marine)

Recommended Detergents

PNC Code	Description
OS2881	S01 STAINLESS STEEL SURFACE POLISHER; 6 BOTTLES X 750ML C/T
OS2883	S03 ALCOHOL BASE DETERGENT; 6 BOTTLES X 750ML; ADR&IMDG&IATA Limited Quantity
OS2884	S04 GLASSES & HARD SURFACES CLEANERS; 6 BOTTLES X 750ML
OS3257	S05 - MULTIPURPOSE DEGREASER; 6PCS X 750ML; ADR&IMDG Limited Quantity