



691346 (PS04RIGHC)

1-glass door prostore Refrigerator 470lt, 0/+10°C, AISI 304, R290

What our App can do for you:



- **Stay Connected:** real-time equipment monitoring ensures you're always up to date
- **Smart Connection:** bluetooth integration for fast, reliable control
- **Control at Your Fingertips:** adjustments made easy for seamless operations
- **Effortless Compliance:** download HACCP data in seconds, simplifying food safety management

Main Features

- Low noise level.
- Complies with main international certification bodies and is CE marked.
- Hidden evaporator thus guaranteeing higher storage capacity and less corrosion problems.
- Optimized airflow within the chamber guarantees uniformity of temperature on all grids.
- Prearranged to fit RS485 port to facilitate connection to a remote computer and integrated HACCP systems.
- Model requires only 1 phase 230V/50Hz supply and can be plugged straight into an existing power socket
- Adjustable temperature range from 0°C to +10°C.
- Internal all-round door LED lighting for best visibility.
- Greater storage space: internal structure with numerous charging positions available to host grids, ensuring higher net capacity.
- Large storage area suitable to contain 520x442 mm grids or shelves to improve net capacity.
- IPX5 frontal water protection.
- This appliance is intended for use in ambient temperatures up to 40°C.
- Tropicalized unit



Construction

- Developed and produced in ISO 9001 and ISO 14001 certified factory.
- Lockable door.
- Inner cell with rounded corners, bottom pressed in only one piece.
- Easy access to the main components for maintenance.
- Stainless steel runners and supports easily disassembled.
- Pressed stainless steel door handle without joints gathering dust and dirt.
- Stainless steel AISI 304 external panels (galvanized external back).
- Internal components removable without the use of tools to facilitate cleaning operations.

User Interface & Data Management

- Fully compliant HACCP digital control: when temperature exceeds critical limits, acoustic and visual alarms are activated. Up to two months of event are kept in memory.
- Large digital white-digit display with cabinet temperature display and setting, and possibility to select the desired levels of humidity. Bluetooth technology included allows to keep HACCP historical data and download them through the app.
- Electrolux Professional Fridge Control APP makes the life easier for our customers:
 - Monitor safety of preservation process thanks to HACCP data & alarms for precise control
 - Save time and easy data management having the possibility to send the HACCP information in excel format directly to e-mail address
 - Quick operations: set the cabinet temperature/humidity/turbocooling and set date/hour
- Connect the product (with accessory) to the OneConnected Platform via Wi Fi or ethernet connection for a seamless remote experience. Real-time monitoring and analytics, alarm management, HACCP data management, APIs, and advanced features keep your fridge fully under control.





A focus on sustainability

Sustainability

- Optical door microswitch to stop the fan once the door is opened, thus minimizing energy waste.
- Automatic evaporation of the defrosting water by hot gas on the top for energy saving.
- Cleaning-free condenser: the structure of the wire frame condenser prevents dust and grease accumulation thus avoiding periodical cleaning operations and reducing energy consumption.
- Removable triple-chamber balloon magnetic gasket to improve insulation and reduce energy consumption and ease of cleaning.
- Frost Watch Control: fully automatic defrost starts only when ice is actually building-up in the evaporator and adapt the defrosting duration to guarantee perfect ice removal while optimizing energy efficiency consumption.
- CFC and HCFC free, highly ecological refrigerant type: R290 (ecological gas in foam: cyclopentane). Hydrocarbon refrigerant gas R290 for the lowest environmental impact (GWP=3), to reduce green house and ozone depletion effects.
- Insulation thickness: 65 mm of polyurethane injected with ecological foaming gas cyclopentane to ensure effective insulation with minimum energy consumption (thermal conductivity: 0,020 W/m*K).

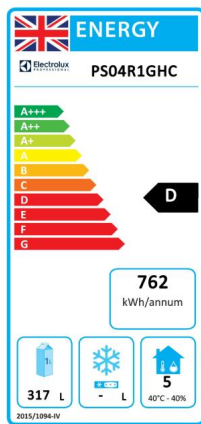
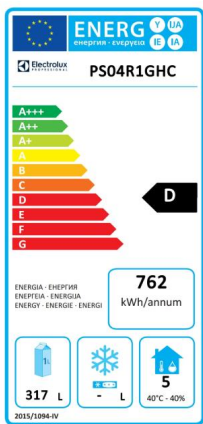

EU energy labelling from 1st July 2016

The European energy labelling scheme for professional refrigerators and freezers is based on requirements setting Minimum Energy Performance standards for commercial refrigeration cabinets sold within the EU. These requirements are designed to drive energy efficiency and environmentally friendly approach for professionals. The European energy labelling scheme will apply to all manufacturers and importers who sell and market products within the EU and it is mandatory across Europe. Important: all products which consume energy above the minimum level will not be able to be sold within the EU from 1 July 2016. SI 2020 No. 1528.

Important: all products which consume energy above the minimum level will not be able to be sold within the EU from 1 July 2016.

Certifications & Recognitions



International system for mutual acceptance of test reports and certificates concerning the safety of electrical and electronic components, equipment, and products.



Product assessed by the manufacturer and deemed to meet EU safety, health, and environmental protection requirements.



Find out more:
ISO Certificates
Electrolux Professional Recognitions

The company reserves the right to make modifications to the products without prior notice. All information correct at time of printing.

2026/05/21

3/6

Technical specifications

Electric		Sustainability	
Supply voltage:	220-240 V/1 ph/50 Hz	Noise level:	57.5 dBA
Electrical power max.:	0.21 kW	Refrigerant type:	R290
Compressor power:	1/4 hp	GWP Index:	3
Key Information:		Refrigeration power:	406 W
Number and type of grids (included):	5 (520x442)	Refrigerant weight:	85 g
Net Volume:	317 lt	Energy Class (EU Reg. 2015/1094):	D
External dimensions, Width:	600 mm	Climate class (EU Reg. 2015/1094):	Heavy Duty (5)
External dimensions, Depth:	700 mm	Energy Efficiency Index-EEI (EU Reg. 2015/1094):	67.45
External dimensions, Depth with Doors Open:	1226 mm	ISO Certificates	
External dimensions, Height:	2040 mm	ISO Standards:	ISO 9001; ISO 14001; ISO 45001; ISO 50001
Number and type of doors:	1 Glass	Type reference/certification group:	P60MTNHC
Internal Dimensions, Width:	472 mm		
Internal Dimensions, Depth:	582 mm		
Internal Dimensions, Height:	1474 mm		
Height adjustment:	15/40 mm		
Type of external material:	Stainless Steel AISI 304		
Type of internal material:	Stainless Steel AISI 304		
Number of positions & pitch:	44; 22 mm		
Gross capacity:	470 liter		
Type of model:	Vertical chilled		
Refrigeration Data			
Control type:	Digital		
Refrigeration power at evaporation temperature:	-10 °C		
Operating temperature min.:	0 °C		
Operating temperature max.:	10 °C		
Operating mode:	Ventilated		
Cooling unit:			
Defrost type:	Evaporator Fan		

Installation drawings

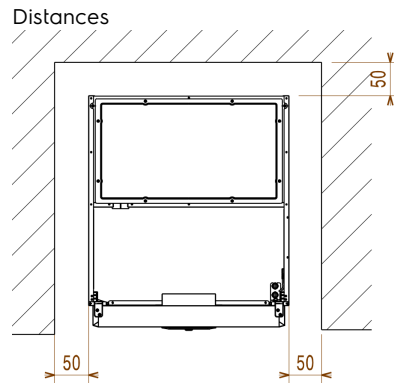
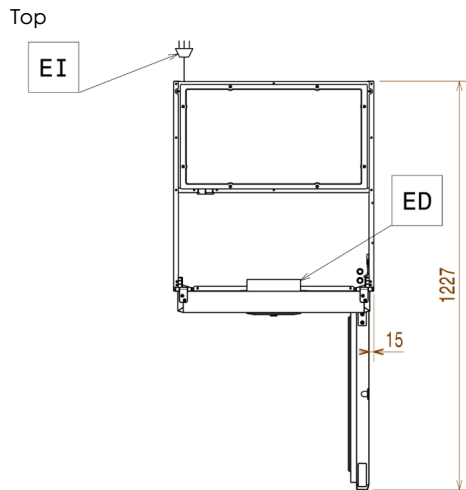
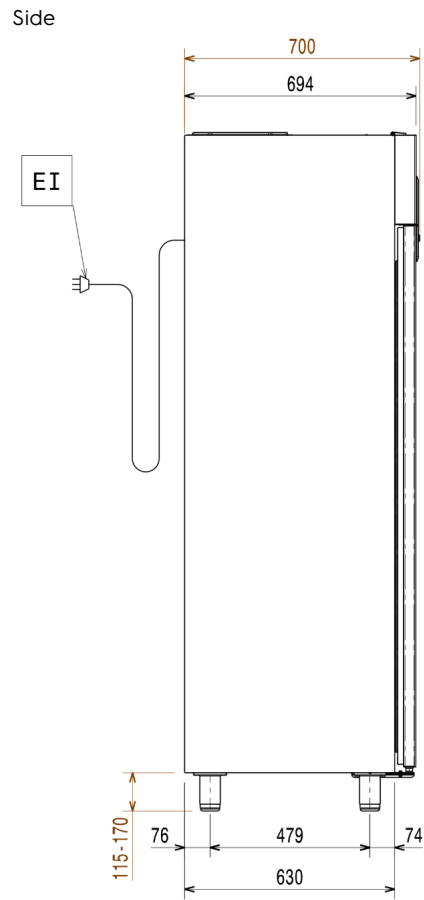
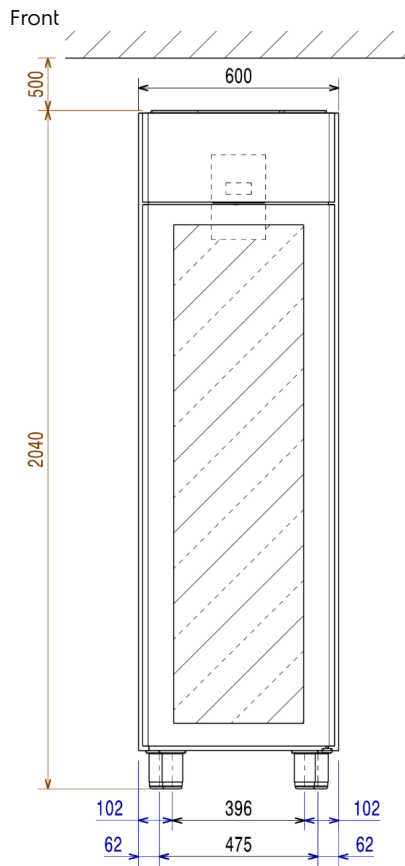

EI = Electrical inlet (power)
RI = Refrigerant Inlet

RO = Refrigerant Outlet

Accessories

Included Accessories

PNC Code	Description	Quantity
880335	Pair of runners for 470 and 720lt prostore cabinets	5
880342	Rilsan-coated grid 520x442mm for Prostore 470l	5

Optional Accessories

PNC Code	Description
----------	-------------

Containers, trays and grids

880321	Stainless steel grid (520x442)
880327	Kit pair of runners (marine)
880328	Base frame for 1/1 GN rack for 470lt prostore
880335	Pair of runners for 470 and 720lt prostore cabinets
880342	Rilsan-coated grid 520x442mm for Prostore 470l

Doors and drawers

881164	PROSTORE GLASS DOOR PROTECTION KIT
--------	------------------------------------

Feet, wheels and ramps

880325	Kit 4 feet, height 200mm
880326	Kit of 4 feet-h=67 (marine)
881035	Kit of 4 small swivelling wheels, 2 with brake, diam 50 mm, not for remote models

Recommended Detergents

PNC Code	Description
OS2881	S01 STAINLESS STEEL SURFACE POLISHER; 6 BOTTLES X 750ML C/T
OS2883	S03 ALCOHOL BASE DETERGENT; 6 BOTTLES X 750ML; ADR&IMDG&IATA Limited Quantity
OS2884	S04 GLASSES & HARD SURFACES CLEANERS; 6 BOTTLES X 750ML
OS3257	S05 - MULTIPURPOSE DEGREASER; 6PCS X 750ML; ADR&IMDG Limited Quantity