



### 863248 (HSCCTDU)

Drive unit with tray unloader, variable speed and legs for cord conveyor for trays

## Main Features

- Available as optional accessory a remote easy-to reach emergency-stop buttons fitted where required.
- Range allows a large number of conveyor combinations.
- Hidden screws eliminate dirt traps.
- Frame integrated motor for easier cleaning of floor.
- Frontal access for easy maintenance.
- Conveyor speed controlled 4 to 15 m/min depending on capacity.
- Straight Drive Unit sustain up to 20 m; with each additional 90° curve the capability decreases by 4 m. For longer distances Central Units are needed.

## Construction

- 304 AISI stainless steel construction throughout
- All surfaces smooth with polished finish.
- Thick welded flanges for sturdy connection between the units.
- For trays up to 375x530mm.
- Stainless steel square 40x40mm tubular legs.
- Free-standing construction delivered with 40x40mm legs.
- Fiber glass reinforcement with 15mm polyurethane cord.
- Main electrical controls protected in a water-resistant electrical cabinet.
- Optional step by step loading for maximum accumulation of trays on the conveyor.



## Recommended Detergents

PNC Code	Description
0S2092	C11 Detergent for dishwashers; one pack of 2 cans of 5lt
0S2093	C13 ECO Detergent for dishwashers; one pack of 2cans of 5lt
0S2094	C12 Rinse aid for dishwashers; one pack of 2 cans of 5lt
0S2281	C11 Detergent for dishwashers; 1 can of 20lt
0S2362	C30 Multipurpose descaler; one pack of 2 cans of 5lt
0S2904	C15 ECO Rinse aid for dishwashers; one pack of 2 cans of 5lt



# Technical specifications

## Electric

Supply voltage:	230 V/1N ph/50/60 Hz
Electrical power max.:	0.75 kW
<b>Key Information:</b>	
External dimensions, Width:	500 mm
External dimensions, Depth:	500 mm
External dimensions, Height:	910 mm
Net weight:	49 kg
Max. speed:	13 m/min
Min. speed - m/min:	6 m/min

Front

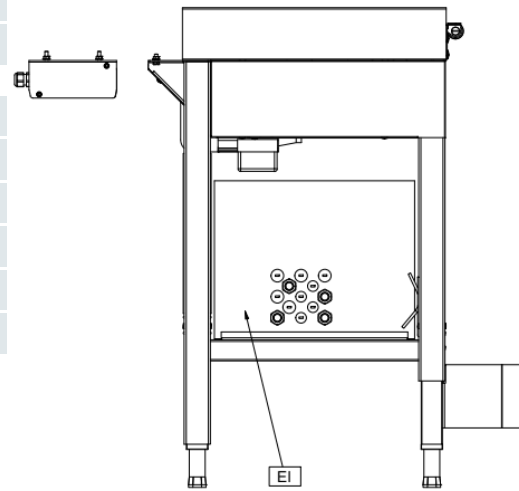

Side

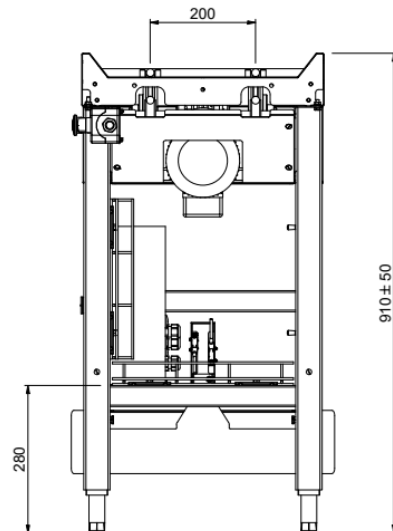

Top

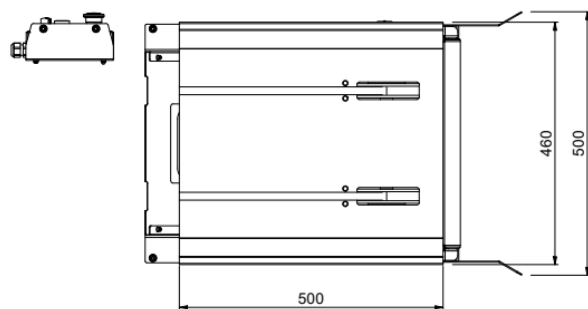

EI = Electrical inlet (power)

DO = Overflow drain pipe



Find out more:  
ISO Certificates  
[Electrolux Professional Recognitions](#)

The company reserves the right to make modifications to the products without prior notice. All information correct at time of printing.

2026/06/01

3/3