



865297 (HSMSF6RL)

Manual pass-through sorting table for 3 baskets, front connection, Right > Left, 1576 mm

Description

Constructed in 304 AISI stainless steel. Basin with sloping bottom, drain with double strainer baskets. Long plastic rollers. Rack-guides inclined towards the sorting side. Square 40x40mm tubular legs with height-adjustable feet. Designed for 500x500mm dishwashing baskets. Attachment to Rack Type dishwasher or other tables on the left front side. Basket feed direction: from right to left.

The pass-through sorting table must be combined with another side-loading sorting table (865257/ 865258/ 865259) on the right side to prolong the length and increase the sorting capacity.

Main Features

- Designed to transport 500x500 mm dishwashing baskets.
- "Key holes" and "snap on" system reduces the number of screws needed for fast and easy installation.
- Long rollers and strainer box easy to remove.
- Manual racks handling toward the dishwasher made easier thanks to the long rollers.
- The pass through sorting table can be combined with other sorting tables to prolong the length and increase the sorting capacity.
- Manual sorting table with side loading can be connected either to a rack type dishwasher or after the roller conveyor, a 90° dishwasher driven curve and a side loader on the loading side.



Construction

- All surfaces smooth with polished finish.
- Constructed in AISI 304 stainless steel with square 40x40mm legs.
- Thick welded flanges for sturdy connection between the units.
- Sloping bottom of the table grants a smooth and rapid drainage.
- Stainless steel strainer baskets easy to remove.
- Manual receiving and sorting operations.
- Connection from front.
- Stainless steel feet 50 mm adjustable in height to align the operation height between the dishwasher and table.
- Optionally equipped with tray slides, a single adjustable over-shelf for empty baskets, a double adjustable over-shelf for sorting of baskets and empty baskets, spray guns, cutlery soaking basin and basin wash nozzles.



Technical specifications

Key Information:

| | |
|------------------------------|----------|
| External dimensions, Width: | 1576 mm |
| External dimensions, Depth: | 1110 mm |
| External dimensions, Height: | 910 mm |
| Net weight: | 42 kg |
| Height adjustment: | 50/50 mm |
| Basket movement: | |
| Basin material: | |
| Type of rollers: | |

Front

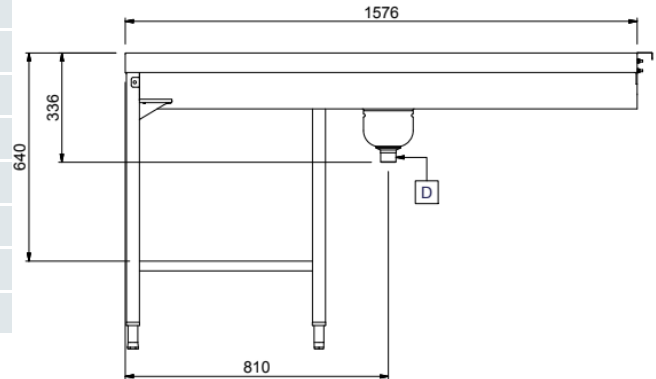

Side

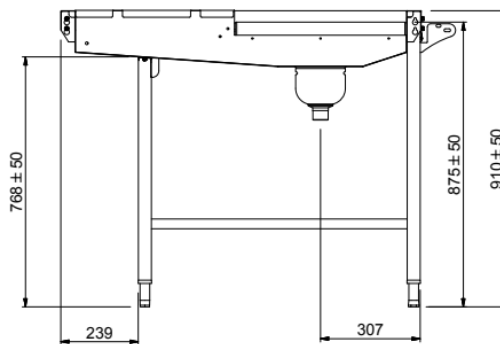

Top

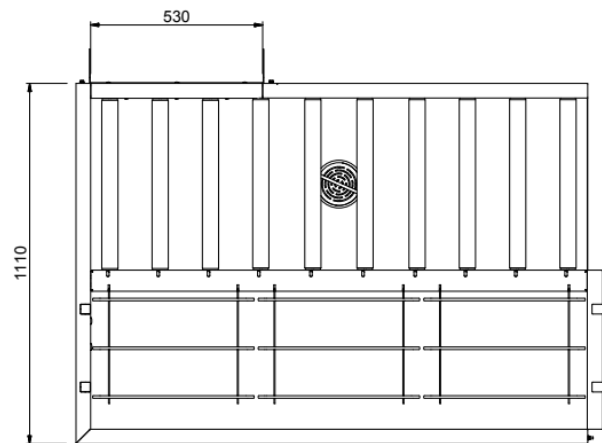

D = Drain

DO = Overflow drain pipe



Find out more:
[ISO Certificates](#)
[Electrolux Professional Recognitions](#)

The company reserves the right to make modifications to the products without prior notice. All information correct at time of printing.

2026/06/10

3/4

Technical specifications

Optional Accessories

| PNC Code | Description |
|--------------------------|-----------------------------------------------------------------------------------|
| Handling system | |
| 863136 | Pre-rinse unit (thermostatic mixer and shower) to be mounted on overshelf |
| 865162 | Emergency stop kit for Rack Type Dishwasher (not for Basic handling system) |
| 865208 | Basket support for vertical stacking of baskets (to be used with overshelf) |
| 865209 | Pre-rinse unit (mixer and shower) |
| 865428 | Double overshelf for pass-through 3-basket sorting table, 1576 mm |
| 865432 | Overshelf for pass-through 3-basket sorting table, 1576 mm |
| 865436 | Tray slide for pass-through 3-basket sorting table, 1576 mm |
| 865437 | Tray slide fixing brackets (3pcs) |
| 865438 | Grid undershelf for 3-basket sorting table |
| 865443 | Pre-wash spray unit, 1500 mm |
| 865444 | Tray slide for sorting table, 500 mm |
| 865445 | Tray slide with waste hole and rubber ring, 500 mm |
| 865447 | Dish scraper |
| 865449 | Water heating kit for wash basin |
| 865457 | Foldable tray slide for pass-through 3-basket sorting table, 1576 mm |
| 865460 | Retractable pre-rinse unit with fixed thermostatic water mixer, hose length, 14mm |
| 865478 | Brackets to support baskets under the sorting table |
| Other accessories | |
| 863259 | Automatic basin wash with timer for 3-basket sorting table |

Recommended Detergents

| PNC Code | Description |
|----------|---------------------------------------------------------------|
| 0S2092 | C11 Detergent for dishwashers; one pack of 2 cans of 5lt. |
| 0S2093 | C13 ECO Detergent for dishwashers; one pack of 2cans of 5lt. |
| 0S2094 | C12 Rinse aid for dishwashers; one pack of 2 cans of 5lt. |
| 0S2281 | C11 Detergent for dishwashers; 1 can of 20lt. |
| 0S2362 | C30 Multipurpose descaler; one pack of 2 cans of 5lt. |
| 0S2904 | C15 ECO Rinse aid for dishwashers; one pack of 2 cans of 5lt. |



Find out more:
ISO Certificates
[Electrolux Professional Recognitions](#)

The company reserves the right to make modifications to the products without prior notice. All information correct at time of printing.

2026/06/10

4/4