



Shipping weight (Package 1):	36 kg
Shipping height (Package 1):	650 mm
Shipping width (Package 1):	500 kg
Shipping depth (Package 1):	650 kg
Shipping weight (Package 2):	10 kg
Shipping width (Package 2):	560 kg
Shipping height (Package 2):	660 kg
Shipping depth (Package 2):	300 kg

CCCRL1 (ECS3D22)

Chilled Beverage Dispenser with 2x9 liter bowls and 1x18 L bowl with agitator and locking lid, R290

PNC Code	Model	Description	Quantity
606468	CS4E2D3D22FCEL X	Base for chilled beverage dispenser, capacity 36 liters, R290	1
607020	CS35ABPAFEWLK EX	2x9 + 1x18 liter bowls for chilled beverage dispenser with agitator and locking lid	1

Main Features

- Agitation function for fresh juices, coffees, or teas with minimal foaming system.
- Easy-off bowl release system for faster and easier assembly and disassembly.
- User friendly design enables machine to dispense product till the very last drop.
- Dispense 3 flavors in (2) 9 L and (1) 18 L easy-clean bowls with 23 cm cup clearance.

Construction

- Refrigerant type: R290.
- Pre-mix dispenser with stainless steel base and clear plastic bowls.
- Fewer removable parts to simplify cleaning and reduce maintenance.
- Temperature range from 1.7 - 5° C.
- Compact size of 52 cm wide saves valuable counter space.
- The air intakes from the bottom and exhaust to back.
- Locking lid for added safety against tampering.





A focus on sustainability

Certifications & Recognitions



Product assessed by the manufacturer and deemed to meet EU safety, health, and environmental protection requirements.



The product meets specific standards for public health protection.



Find out more:
[ISO Certificates](#)
[Electrolux Professional Recognitions](#)

The company reserves the right to make modifications to the products without prior notice. All information correct at time of printing.

13/02/2026

2/4

Technical specifications

Electric

Supply voltage:	220-240 V /1N ph/50/60 Hz
Electrical power max.:	0.6 kW

Key Information:

Net weight:	32 kg
Shipping weight (Package 1):	36 kg
Shipping width (Package 1):	500 kg
Shipping height (Package 1):	650 mm
Shipping depth (Package 1):	650 kg
Shipping weight (Package 2):	10 kg
Shipping width (Package 2):	560 kg
Shipping height (Package 2)	660 kg
Shipping depth (Package 2):	300 kg

Sustainability

Refrigerant type:	R290
Refrigerant weight:	85 g

Installation drawings

Front

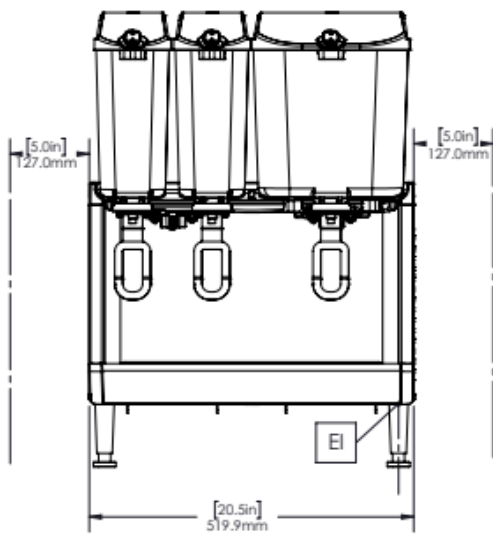

Side

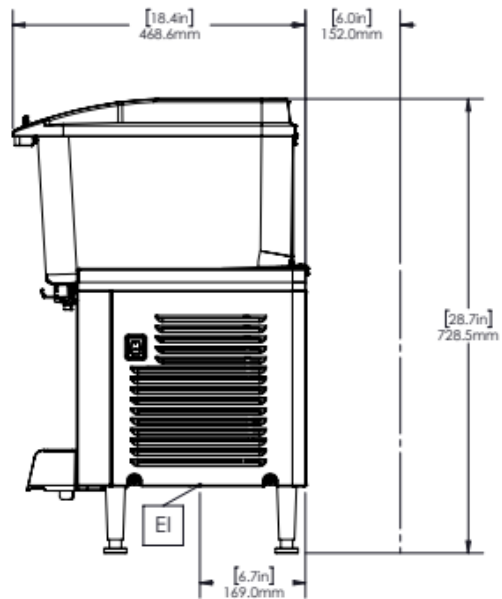

Top

