



738247 (KCHGM12R)

1-Hinged Glass Door Full Height Merchandiser Refrigerator 25" Long 12 Cu. Ft.

Description

1-glass door refrigerator with exterior back panel, bottom panel, and top panel in galvanized steel, exterior side panels in painted steel; interior back, side, and top panels in painted aluminum, and internal bottom panel in 304 stainless steel. Durable and easy to clean for daily commercial use. Control with cabinet temperature display. Self-closing door feature lock and key.

Electronic control.

R290 gas in refrigeration circuit.

ETL Safety and Sanitation certified.

3/5 Years warranty.

Main Features

- External temperature display.
- Bright LED illumination, enhancing product visibility for impactful merchandising
- Removable gasket for easy cleaning operations.
- Fin & Tube Condenser improves performance in high temperature environments.
- Electronic Temperature Control, quick and simple to set, with control display for easy monitoring.
- Automatic Defrost Cooling System provides worry-free performance.
- Heavy duty Vinyl coated steel shelves.
- Cabinet completely insulated with high density polyurethane for low environmental impact.
- Adjustable shelves for flexible storage
- Decorative illuminated header, customizable for enhanced branding capability
- On/off switch controls interior LED lights
- Back bottom mounted cooling unit guarantee an easy access and cleaning.
- Removable rubber bumper guards for airflow spacing and shock absorption

Construction

- Painted black steel exterior, for durable and sleek modern finish
- Self closing doors.
- White aluminum interior, bright and clean polished look for elevated presentation
- Lockable door.
- Electronic control to select temperatures.
- Pre-wired heavy duty power cord.
- Heavy duty door hinges.
- Heavy duty casters.
- Magnetic gasket removable without tools for easy cleaning.

Sustainability

- CFC and HCFC free, highly ecological refrigerant type: R290 (ecological gas in foam: cyclopentane). Hydrocarbon refrigerant gas R290 for the lowest environmental impact (GWP=3), to reduce green house and ozone depletion effects.
- Hydrocarbon refrigerant gas R290 for the lowest environmental impact (GWP=3) - CFC and HCFC free.
- High efficiency components to minimize the energy consumption still guaranteeing the highest performances.
- Interior LED light to save energy and for best internal visibility.
- 60 mm insulation for energy saving.

Optional Accessories

PNC Code	Description
Other Accessories	
880611	Shelf clips (4-pack)
880619	Shelf (Gray) for 12 Cu. Ft. Merchandiser (Glass Door)
880710	Shelf Label Support (Gray) for 12 Cu. Ft. Merchandiser (Glass Door) (485mm)
880731	Shelf (White) for 12 Cu. Ft. Merchandiser (Glass Door)
880735	Shelf Label Support (White) for 12 Cu. Ft. Merchandiser (Glass Door) (485mm)

Technical specifications

Electric

Supply voltage:	115 V/1 ph/60 Hz
Electrical power max:	0.31 kW
Plug type:	USA NEMA 5-15P
Current consumption:	3 Amps
Compressor power:	1/5 hp
Power Cable Length:	2500 mm

Capacity:

Gross capacity:	12 cu.feet
------------------------	------------

Key Information:

Number and type of grids (included):	3 (458x503)
Door hinges:	Right Side
External dimensions, Width:	25 " (635 mm)
External dimensions, Depth:	26 " (660 mm)
External dimensions, height:	65 15/16" (1674 mm)
Number and type of doors:	1 Glass
Internal Dimensions (depth):	21 11/16" (551.18 mm)
Internal Dimensions (height):	39 " (990.6 mm)
Internal Dimensions (width):	20 3/8" (518.16 mm)
Shipping width:	26 9/16" (675 mm)
Shipping depth:	28 15/16" (735 mm)
Shipping height:	68 11/16" (1745 mm)
Shipping weight:	247 lbs (112 kg)
Shipping volume:	30.57 ft ³ (0.87 m ³)
Type of external material:	Black Prepainted Steel
Type of internal material:	White Prepainted Aluminium
Approvals	ETL C&US;ETL SANITATION

Refrigeration Data

Operating temperature min.:	32 °F (0 °C)
Operating temperature max.:	41 °F (5 °C)
Defrost type:	Auto Defrost
Evaporator type	Finned
Refrigerant unit side:	Bottom

Sustainability

Refrigerant type:	R290
GWP Index:	3
Refrigerant weight:	85 g

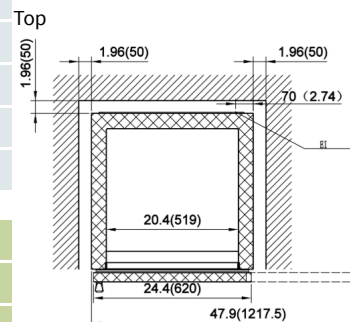
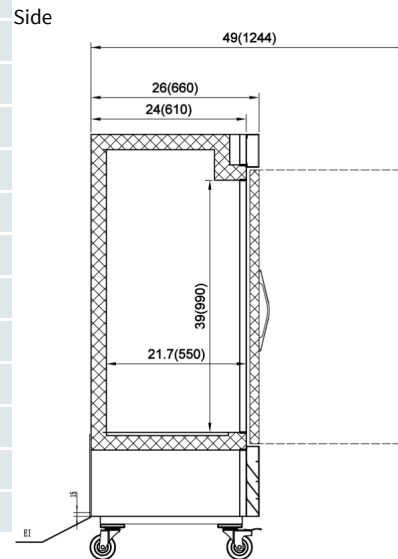
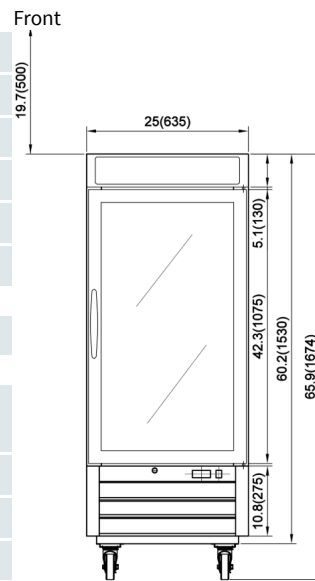

EI = Electrical inlet (power)

RO = Refrigerant Outlet

RI = Refrigerant Inlet

