



738256 (KCHST48.12)

2-Door Sandwich/Salad Prep Table 48" Long 12-1/6 Pan

Description

2-door sandwich/salad refrigerated preparation table. Exterior back panel and exterior bottom panel in galvanized steel, exterior side and top panels in 430 stainless steel; interior back, top panels and interior bottom panel in 304 stainless steel, worktop in 304 stainless steel. Built-in refrigeration unit and an insulated lid to maintain food freshness. Fin & Tube Condenser improves performance in high-temperature environments. Automatic Defrost Cooling System to provide worry-free performances. Full-depth cutting board of 48x11.4x0.5 in. Control panel, Vinyl-Coated Steel adjustable shelves, removable door gaskets and self-closing doors with 90-degree stay-open feature. Temperature range: +33/+41°F.

R290 gas in the refrigeration circuit.
ETL Safety and Sanitation certifications.
3/5 Years warranty.

Main Features

- External temperature display.
- Removable gasket for easy cleaning operations.
- Fin & Tube Condenser improves performance in high temperature environments.
- Automatic Defrost Cooling System provides worry-free performance.
- Electronic Temperature Control, quick and simple to set, with control display for easy monitoring.
- Full Depth cutting board.
- Cabinet completely insulated with high density polyurethane for low environmental impact.
- Heavy duty Vinyl coated steel shelves.
- Adjustable shelves for flexible storage
- Removable rubber bumper guards for airflow spacing and shock absorption
- Back bottom mounted cooling unit guarantee an easy access and cleaning.
- Integrated polyethylene (PE) cutting board included for food-safe, durable prep surface

Construction

- Stainless steel interior and exterior, durable and easy to clean for daily commercial use.
- White polystyrene interior side panels, for high impact resistance
- Holds 12 1/6 pans.
- Insulated lid maintains food freshness.
- Heavy duty casters.
- Pre-wired heavy duty power cord.
- Heavy duty door hinges.
- Magnetic gasket removable without tools for easy cleaning.
- Self-closing door with 90-degree stay-open feature.
- Stainless steel worktop, durable functionality

Sustainability

- CFC and HCFC free, highly ecological refrigerant type: R290 (ecological gas in foam: cyclopentane). Hydrocarbon refrigerant gas R290 for the lowest environmental impact (GWP=3), to reduce green house and ozone depletion effects.
- Hydrocarbon refrigerant gas R290 for the lowest environmental impact (GWP=3) - CFC and HCFC free.
- High efficiency components to minimize the energy consumption still guaranteeing the highest performances.
- 58 mm insulation for energy saving

Optional Accessories

| PNC Code | Description |
|------------------------------------|--|
| Containers, Trays and Grids | |
| 880597 | Shelf (left/right) for 48" & 72" Mega Top, Salad Top, Undercounter, and Worktop |
| 880611 | Shelf clips (4-pack) |
| Doors and Drawers | |
| 880616 | Drawers Kit for L/R section of 48" & 72" Mega Top, Salad Top, Undercounter Refrigerator, and Work Top Refrigerator |

Technical specifications

Electric

| | |
|------------------------------|------------------|
| Supply voltage: | 115 V/1 ph/60 Hz |
| Electrical power max: | 0.72 kW |
| Plug type: | USA NEMA 5-15P |
| Current consumption: | 4.3 Amps |
| Compressor power: | 1/3 hp |
| Power Cable Length: | 2500 mm |

Capacity:

| | |
|------------------------|------------|
| Gross capacity: | 12 cu.feet |
|------------------------|------------|

Key Information:

| | |
|---|--|
| Number and type of grids (included): | 2 (538x425) |
| Door hinges: | 1 Left+1 Right |
| External dimensions, Width: | 48 1/4" (1225 mm) |
| External dimensions, Depth: | 29 15/16" (760 mm) |
| External dimensions, height: | 43 5/16" (1100 mm) |
| Number and type of doors: | 2 Full |
| Internal Dimensions (depth): | 23 13/16" (605 mm) |
| Internal Dimensions (height): | 23 1/2" (597 mm) |
| Internal Dimensions (width): | 42 13/16" (1088 mm) |
| Net weight: | 223 lbs (101 kg) |
| Shipping width: | 49 13/16" (1265 mm) |
| Shipping depth: | 31 1/2" (800 mm) |
| Shipping height: | 47 1/4" (1200 mm) |
| Shipping weight: | 333 lbs (151 kg) |
| Shipping volume: | 42.88 ft ³ (1.21 m ³) |
| Type of external material: | Stainless Steel |
| Type of internal material: | Polystyrene |
| Approvals | ETL C&US;ETL SANITATION |

Refrigeration Data

| | |
|------------------------------------|--------------|
| Operating temperature min.: | 32 °F (0 °C) |
| Operating temperature max.: | 41 °F (5 °C) |
| Defrost type: | Auto Defrost |
| Evaporator type | Finned |
| Refrigerant unit side: | Back |

Sustainability

| | |
|----------------------------|------|
| Refrigerant type: | R290 |
| GWP Index: | 3 |
| Refrigerant weight: | 90 g |

Front

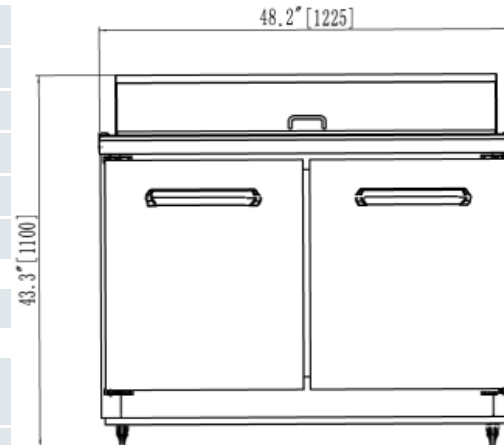

Side

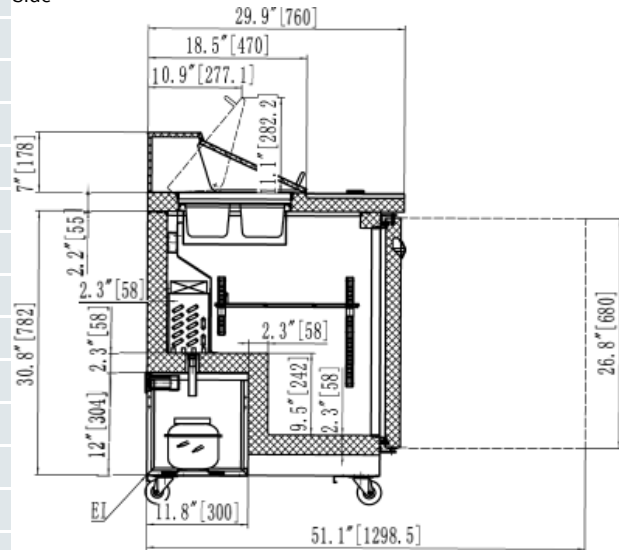

Top

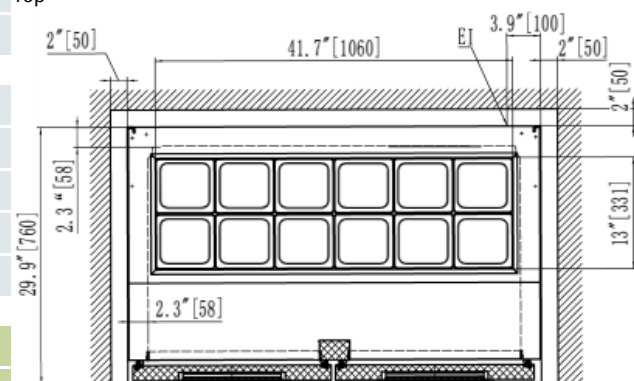

EI = Electrical inlet (power)

RO = Refrigerant Outlet

RI = Refrigerant Inlet

