



738393 (KCHCB36R)
2-Drawer Chef Base Refrigerator 38" Long

Description

2-drawer Refrigerated base with exterior back panel, exterior side panels, and exterior control panel in 430 stainless steel, exterior bottom panel in galvanized steel; interior back panel in 430 stainless steel, interior bottom and interior side panels in 304 stainless steel. Top in 304 stainless steel. Electronic temperature control.

Marine edge stainless steel countertop supports up to 1089 lbs. (493.96 kg).

Stainless steel drawer slides support up to 152 lbs. (69 kg) static capacity.

R290 gas in the refrigeration circuit.

ETL Safety and Sanitation certified.

3/5 Years warranty

Main Features

- External temperature display.
- Heavy-duty construction with 1,089 lbs. load capacity on top.
- Cabinet completely insulated with high density polyurethane for low environmental impact.
- Recommended maximum temperature on worktop surface is 572°F.
- Insulation of the top guaranteed thanks to the Integrated ceramic fiber heat shield.
- Removable gasket for easy cleaning operations.
- Fin & Tube Condenser improves performance in high temperature environments.
- Automatic Defrost Cooling System provides worry-free performance.
- Electronic Temperature Control, quick and simple to set, with control display for easy monitoring.
- Marine edge top, for containing spills
- Removable rubber bumper guards for airflow spacing and shock absorption
- Drawer slides support up to 152 lbs. static capacity.
- Side-mounted refrigeration system improves airflow, reduces heat buildup behind the unit, and allows easy service access

Construction

- Stainless steel interior and exterior, durable and easy to clean for daily commercial use.
- Ceramic insulated top
- Pre-wired heavy duty power cord.
- Heavy duty casters.
- Magnetic gasket removable without tools for easy cleaning.
- Heavy duty drawer runners.
- Front and rear ventilation panel design improves airflow for effective heat release from the refrigeration system.

Sustainability

- CFC and HCFC free, highly ecological refrigerant type: R290 (ecological gas in foam: cyclopentane). Hydrocarbon refrigerant gas R290 for the lowest environmental impact (GWP=3), to reduce green house and ozone depletion effects.
- Hydrocarbon refrigerant gas R290 for the lowest environmental impact (GWP=3) - CFC and HCFC free.
- High efficiency components to minimize the energy consumption still guaranteeing the highest performances.
- 50 mm insulation for energy saving.

Optional Accessories

PNC Code	Description
Feet, Wheels and Ramps	
206445	1 Adjustable Foot

Technical specifications

Electric

Supply voltage:	115 V/1 ph/60 Hz
Electrical power max:	0.22 kW
Plug type:	USA NEMA 5-15P
Current consumption:	2.1 Amps
Compressor power:	1/5 hp
Power Cable Length:	2500 mm

Capacity:

Gross capacity:	5.33253 cu.feet
------------------------	-----------------

Key Information:

Door hinges:	Slide in
External dimensions, Width:	38 " (965 mm)
External dimensions, Depth:	31 7/8" (810 mm)
External dimensions, height:	26 " (660 mm)
Internal Dimensions (depth):	26 3/4" (680 mm)
Internal Dimensions (height):	14 15/16" (379 mm)
Internal Dimensions (width):	21 1/4" (540 mm)
Net weight:	176 lbs (80 kg)
Shipping width:	32 7/8" (835 mm)
Shipping depth:	39 3/16" (995 mm)
Shipping height:	28 3/8" (720 mm)
Shipping weight:	198 lbs (90 kg)
Shipping volume:	21.12 ft ³ (0.6 m ³)
Type of external material:	Stainless Steel
Type of internal material:	304 AISI
Approvals	ETL C&US;ETL SANITATION
Number of drawers:	2

Refrigeration Data

Operating temperature min.:	32 °F (0 °C)
Operating temperature max.:	41 °F (5° C)
Defrost type:	Auto Defrost
Evaporator type	Finned
Refrigerant unit side:	Right

Sustainability

Refrigerant type:	R290
GWP Index:	3
Refrigerant weight:	80 g

Front

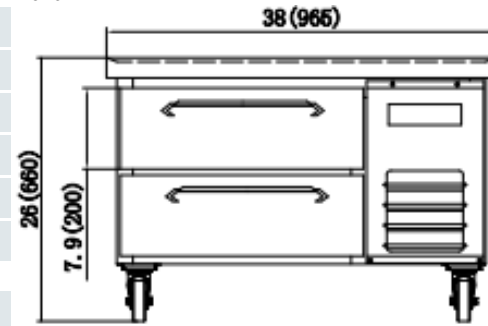

Side

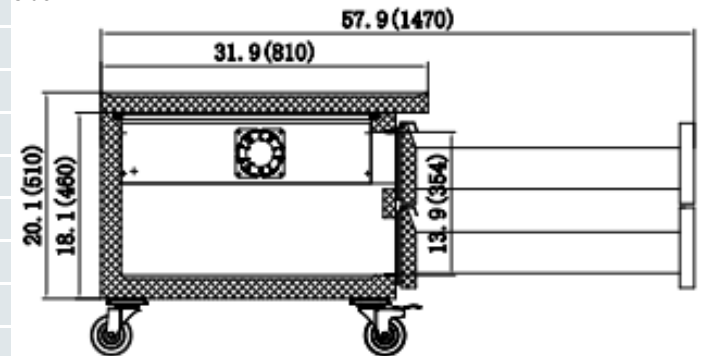

Top

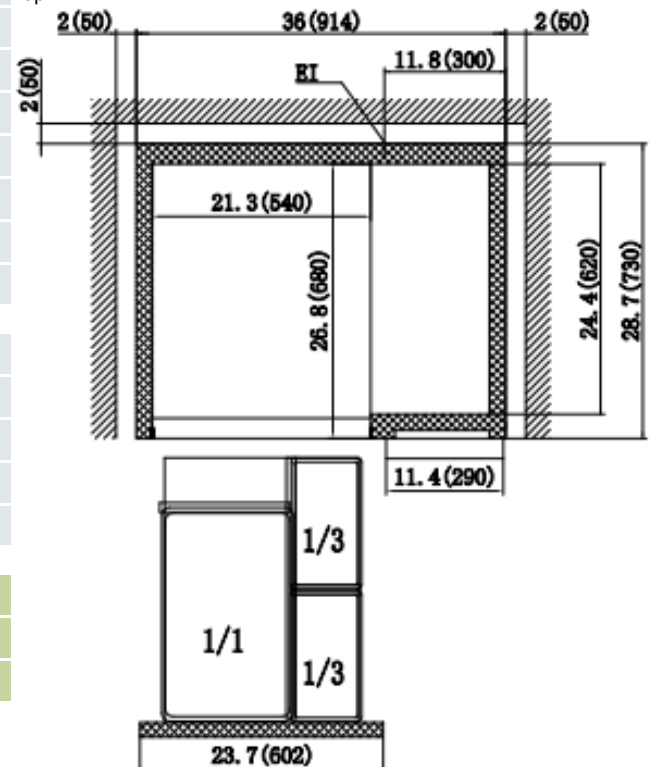

EI = Electrical inlet (power)

