

**218757 (ZCOG61T3G3B)**

Magistar Combi TS combi boiler oven with touch screen control, 5 600x400mm, gas, 3 cooking modes (automatic, recipe program, manual), automatic cleaning, 3-glass door, for bakery/pastry, pitch 80mm

Main Features

- 6-point multi sensor core temperature probe for maximum precision and food safety.
- Programs mode: a maximum of 1000 recipes can be stored in the oven's memory, to recreate the exact same recipe at any time. The recipes can be grouped in 16 different categories to better organize the menu. 16-step cooking programs also available.
- Dry, hot convection cycle (25 °C - 300 °C): ideal for low humidity cooking.
- Combination cycle (25 °C - 300 °C): combining convected heat and steam to obtain humidity controlled cooking environment, accelerating the cooking process and reducing weight loss.
- Low temperature Steam cycle (25 °C - 99 °C): ideal for sous-vide, re-thermalization and delicate cooking.
Steam cycle (100 °C): seafood and vegetables.
High temperature steam (101 °C - 130 °C).
- Built-in steam generator for highly precise humidity and temperature control according to the chosen settings.
- Real humidity control based upon Lambda Sensor to automatically recognize quantity and size of food for consistent quality results.
- Fan with 7 speed levels from 300 to 1500 RPM and reverse rotation for optimal evenness. Fan stops in less than 5 seconds when door is opened.
- Automatic fast cool down and pre-heat function.
- MultiTimer function to manage up to 60 different cooking cycles at the same time, improving flexibility and ensuring excellent cooking results. Can be saved up to 200 MultiTimer programs.
- Automatic mode including 9 food families (meat, poultry, fish, vegetables, pasta/rice, eggs, savory and sweet bakery, bread, dessert) with 100+ different pre-installed variants. Through Automatic Sensing Phase the oven optimizes the cooking process according to size, quantity and type of food loaded to achieve the selected cooking result. Real time overview of the cooking parameters. Possibility to personalize and save up to 70 variants per family.
- Cycles :
 - Regeneration (ideal for banqueting on plate or rethermalizing on tray),
 - Low Temperature Cooking (to minimize weight loss and maximize food quality) Patented US7750272B2 and related family,
 - Proving cycle,
 - EcoDelta cooking, cooking with food probe maintaining preset temperature difference between the core of the food and the cooking chamber,
 - Sous-vide cooking,
 - Static Combi (to reproduce traditional cooking from static oven),
 - Pasteurization of pasta,
 - Dehydration cycle (ideal for drying fruits, vegetables, meats, seafood),
 - Food Safe Control (to automatically monitor safety of cooking process in compliance with HACCP hygienic standards) Patented US6818865B2 and related family,
 - Advanced Food Safe Control (to drive the cooking with pasteurization factor).
- Back-up mode with self-diagnosis is automatically activated if a failure occurs to avoid downtime.
- 6-point multi sensor core temperature probe for maximum precision and food safety (optional accessory).
- Grease Collector: predisposed for integrated grease drain and collection for safer operation (dedicated base as optional accessory).

- AirFlow air distribution system to achieve maximum performance in chilling/heating evenness and temperature control thanks to a special design of the chamber combined with high precision variable speed fan.
- OptiFlow air distribution system to achieve maximum performance in chilling/heating evenness and temperature control thanks to a special design of the chamber.
- Zanussi Professional recommends the use of treated water to guarantee optimal cooking results and extend the life of the appliance. Check local water condition to select the appropriate water filter. More info available on the website.
- Short cleaning cycle: optimized cleaning cycle with a duration of just 33 minutes, improving efficiency and reducing downtime.
- HP Automatic Cleaning: automatic and built-in self cleaning system with 4 automatic cycles (short, medium, intensive, rinse) and integrated descale of the steam generator.

Construction

- 304 AISI stainless steel construction throughout.
- IPX5 spray water protection certification for easy cleaning.
- Hygienic internal chamber with all rounded corners for easy cleaning.
- Integrated spray gun with automatic retracting system for fast rinsing.
- Triple thermo-glazed door with 2 hinged inside panels for easy cleaning and double LED lights line.
- Front access to control board for easy service.

User Interface & Data Management

- Pictures upload for full customization of cooking cycles.
- Trainings and guidances supporting materials easily accessible by scanning QR-Code with any mobile device.
- Make-it-mine feature to allow full personalization or locking of the user interface.
- USB port to download HACCP data, share cooking programs and configurations. USB port also allows to plug-in sous-vide probe (optional accessory).
- High resolution full touch screen interface (translated in more than 30 languages) - color-blind friendly panel.
- Automatic consumption visualization at the end of the cycle.
- Calendar works as an agenda where the user can plan the daily work and receive personalized alerts for each task.
- SoloMio lets the user group the favorite functions in the homepage for immediate access.
- Connectivity for remote real time access, easy HACCP management, equipment uptime increase, consumption tracking and energy management (requires optional accessory).



A focus on sustainability

Sustainability

- Reduced power function for customized slow cooking cycles.
- Cooking Optimizer function organizes the cooking sequence of the chosen cycles optimizing the work in the kitchen from a time and energy efficiency point of view.
- Zero Waste provides chefs with useful tips for minimizing food waste. Zero Waste is a library of Automatic recipes that aims to: - give a second life to raw food close to expiration date (e.g., from milk to yogurt) - obtain genuine and tasty dishes from overripe fruit/vegetables (usually considered not appropriate for sale) - promote the use of typically discarded food items (e.g., carrot peels).
- C22 and C25 detergents are formulated without phosphates and phosphorus (C25 is also maleic acid-free), making them safe for both the environment and human health.
- The outer cardboard packaging is made from 70% recycled materials and FSC*-certified paper, printed with eco-friendly, water-based ink to support sustainability and environmental responsibility. (**Forest Stewardship Council is the world's leading organization for sustainable forest management*).
- Triple-glass door minimize your energy loss. ***Approx. -10% of idle energy consumption in convection based on test in compliance with ASTM Standard F2861-20*
- Save energy, water, detergent and rinse aid with green functions.
- Automatic and built-in self cleaning system with 4 automatic cycles (short, medium, intensive, rinse) and integrated descale of the steam generator.

Certifications & Recognitions



Product assessed by the manufacturer and deemed to meet EU safety, health, and environmental protection requirements.



International system for mutual acceptance of test reports and certificates concerning the safety of electrical and electronic components, equipment, and products.



Product acceptable for use in a commercial food establishment and meets applicable construction, performance, and material requirements.



Ensures compliance with the quality, safety, and performance requirements for placement in the Dutch market.



UL Verification is an independent, science-based process that validates marketing claims, helping distinguish verified facts from fiction.



Technical specifications

Electric

Supply voltage:	220-240 V/1 ph/50 Hz
Electrical power max.:	1.1 kW
Electrical power, default:	1.1 kW

Gas

Total thermal load:	76429 BTU (19 kW)
Gas Power:	19 kW
Standard gas delivery:	Natural Gas G20
ISO 7/1 gas connection diameter:	1/2" MNPT

Water:

Max inlet water supply temperature:	30 °C
Chlorides:	<17 ppm
Conductivity:	0 µS/cm
Drain "D":	50mm
Water inlet connections "CW11-CW12":	3/4"
Pressure, bar min/max:	1-6 bar

Capacity:

Trays type:	5 - 400x600 mm
Max load capacity:	30 kg

Key Information:

External dimensions, Width:	867 mm
External dimensions, Depth:	775 mm
Weight:	138 kg
External dimensions, Height:	808 mm
Net weight:	138 kg
Shipping weight (gross):	155 kg
Shipping volume:	0.89 m ³

ISO Certificates

ISO Standards:	ISO 9001; ISO 14001; ISO 45001; ISO 50001
----------------	---

Installation drawings

Front

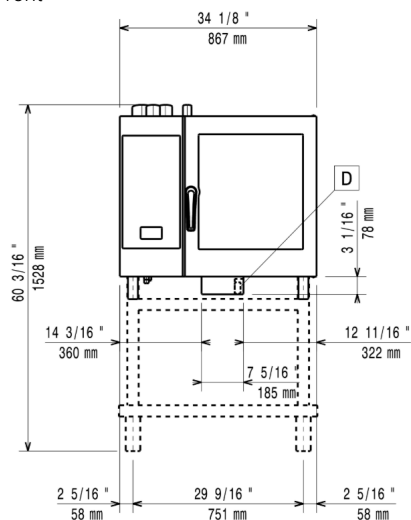

Side

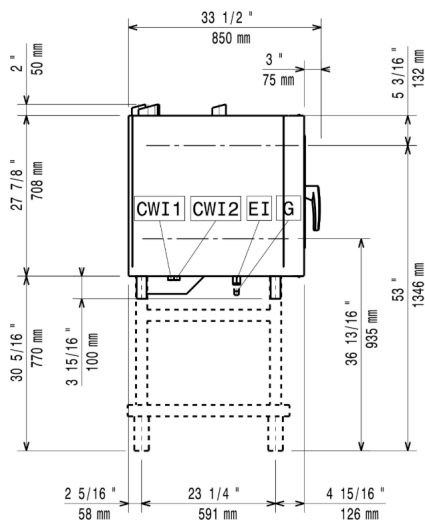

Top

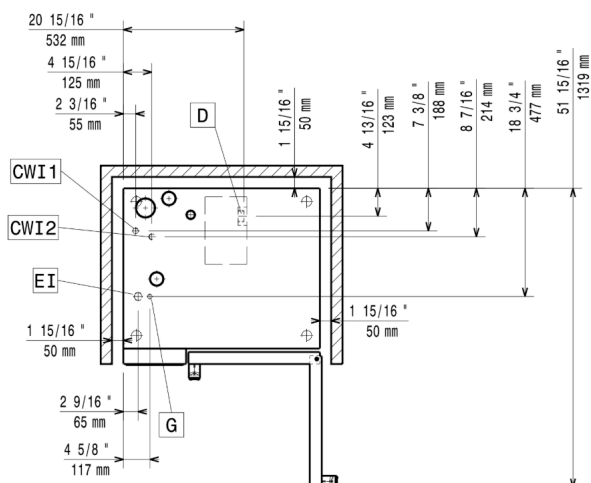

CWI1 = Cold Water inlet 1 (cleaning)

G = Gas connection

DO = Overflow drain pipe

D = Drain

EI = Electrical inlet (power)

Accessories

Included Accessories

PNC Code	Description	Quantity
922655	Bakery/pastry rack kit for 6 GN 1/1 oven with 5 racks 400x600mm and 80mm pitch	1

Optional Accessories

PNC Code	Description
----------	-------------

Bases & base accessories

922382	Tray support for 6 & 10 GN 1/1 disassembled open base
922612	Open base with tray support for 6 & 10 GN 1/1 oven
922614	Cupboard base with tray support for 6 & 10 GN 1/1 oven
922615	Hot cupboard base with tray support for 6 & 10 GN 1/1 oven holding GN 1/1 or 400x600mm
922653	Open base for 6 & 10 GN 1/1 oven, disassembled - NO accessory can be fitted with the exception of 922382
922690	Tray support for 6 & 10 GN 1/1 oven base
922702	Bakery/pastry runners 400x600mm for 6 & 10 GN 1/1 oven base

Cleaning solutions

922386	Wall mounted detergent tank holder
922618	External connection kit for liquid detergent and rinse aid
922699	Detergent tank holder for open base

Containers, trays and grids

922017	Pair of AISI 304 stainless steel grids, GN 1/1
922036	Pair of grids for whole chicken (8 per grid - 1,2kg each), GN 1/1
922062	AISI 304 stainless steel grid, GN 1/1
922086	Grid for whole chicken (4 per grid - 1,2kg each), GN 1/2
922189	Baking tray for 5 baguettes in perforated aluminum with silicon coating, 400x600x38mm
922190	Baking tray with 4 edges in perforated aluminum, 400x600x20mm
922191	Baking tray with 4 edges in aluminum, 400x600x20mm
922239	Pair of frying baskets
922264	AISI 304 stainless steel bakery/pastry grid 400x600mm
922266	Grid for whole chicken (8 per grid - 1,2kg each), GN 1/1
922324	Kit universal skewer rack and 4 long skewers for GN 1/1 ovens
922348	Multipurpose hook
922362	Grid for whole duck (8 per grid - 1,8kg each), GN 1/1
922651	Dehydration tray, GN 1/1, H=20mm
922652	Flat dehydration tray, GN 1/1
922713	Mesh grilling grid, GN 1/1
922746	Tray for traditional static cooking, H=100mm
922747	Double-face griddle, one side ribbed and one side smooth, 400x600mm
925000	Non-stick universal pan, GN 1/1, H=20mm
925001	Non-stick universal pan, GN 1/1, H=40mm
925002	Non-stick universal pan, GN 1/1, H=60mm

Accessories

PNC Code	Description
Containers, trays and grids	
925003	Double-face griddle, one side ribbed and one side smooth, GN 1/1
925004	Aluminum grill, GN 1/1
925005	Frying pan for 8 eggs, pancakes, hamburgers, GN 1/1
925006	Flat baking tray with 2 edges, GN 1/1
925007	Baking tray for 4 baguettes, GN 1/1
925008	Potato baker for 28 potatoes, GN 1/1
925009	Non-stick universal pan, GN 1/2, H=20mm
925010	Non-stick universal pan, GN 1/2, H=40mm
925011	Non-stick universal pan, GN 1/2, H=60mm
925012	Kit of 6 non-stick universal pans, GN 1/1, H=20mm
925013	Kit of 6 non-stick universal pans, GN 1/1, H=40mm
925014	Kit of 6 non-stick universal pan GN 1/1, H=60mm
Doors and drawers	
922265	Double-step door opening kit
Drains	
922636	Stainless steel drain kit for 6 & 10 GN oven, dia=50mm
922637	Plastic drain kit for 6 & 10 GN oven, dia=50mm
Feet, wheels and ramps	
922003	Wheel kit for 6 & 10 GN 1/1 and 2/1 GN oven base (not for the disassembled one)
922351	4 flanged feet for 6 & 10 GN , 2", 100-130mm
922394	4 SERVICE FEET FOR 6&10 GN OVENS, 100MM - MARINE
922688	4 high adjustable feet for 6 & 10 GN ovens, 100-115MM
922693	4 adjustable feet with black cover for 6 & 10 GN ovens, 100-115mm
922745	4 high adjustable feet for 6 & 10 GN ovens, 230-290mm
Food probes	
922281	USB probe for sous-vide cooking
922390	USB single point probe
922714	Probe holder for liquids
Grease/oil management	
922321	Grease collection tray, GN 1/1, H=100 mm
922329	Grease collection tray, GN 1/1, H=40 mm
922752	Trolley for grease collection kit
Handling - bakery	
922607	Bakery/pastry tray rack with wheels holding 400x600mm grids for 6 GN 1/1 oven and blast chiller freezer, 80mm pitch (5 runners)
922655	Bakery/pastry rack kit for 6 GN 1/1 oven with 5 racks 400x600mm and 80mm pitch

Accessories

PNC Code	Description
Handling - gastronorm	
922600	Tray rack with wheels, 6 GN 1/1, 65mm pitch
922606	Tray rack with wheels 5 GN 1/1, 80mm pitch
922626	Trolley for slide-in rack for 6 & 10 GN 1/1 oven and blast chiller freezer
Handling - multipurpose	
922684	Fixed tray rack for 6 GN 1/1 and 400x600mm grids
Installation solutions	
922660	Heat shield for stacked ovens 6 GN 1/1 on 6 GN 1/1
922661	Heat shield for stacked ovens 6 GN 1/1 on 10 GN 1/1
922662	Heat shield for 6 GN 1/1 oven
922670	Kit to convert from natural gas to LPG
922671	Kit to convert from LPG to natural gas
922706	Chimney adaptor needed in case of conversion of 6 GN 1/1 or 6 GN 2/1 ovens from natural gas to LPG
Other accessories	
922338	Smoker for lengthwise and crosswise oven
Slide-in supports	
922610	Slide-in rack with handle for 6 & 10 GN 1/1 oven
Spray units	
922171	External side spray unit (needs to be mounted outside and includes support to be mounted on the oven)
Stacking kits	
922436	Riser on feet (h=250mm) for 2x6 GN 1/1 ovens or a 6 GN 1/1 oven on base
922622	Stacking kit for 6 GN 1/1 oven placed on gas 6 GN 1/1 oven
922623	Stacking kit for 6 GN 1/1 oven placed on gas 10 GN 1/1 oven
922630	Trolley for mobile rack for 6 GN 1/1 on 6 or 10 GN 1/1 ovens
922632	Riser on feet for 2 6 GN 1/1 ovens or a 6 GN 1/1 oven on base
922635	Riser on wheels for stacked 2x6 GN 1/1 ovens, height 250mm
922657	Stacking kit for 6 GN 1/1 combi or convection oven on 15&25kg blast chiller/freezer crosswise
922704	Wheels for stacked ovens
Ventilation	
922440	Steam optimizer
922678	Flue condenser for gas oven
922728	Exhaust hood with fan for 6 & 10 GN 1/1 ovens
922732	Exhaust hood with fan for stacking 6+6 or 6+10 GN 1/1 ovens
922733	Exhaust hood without fan for 6&10 1/1GN ovens
922737	Exhaust hood without fan for stacking 6+6 or 6+10 GN 1/1 ovens
922751	Hood Hopper to directly connect the Hood to the centralized ventilation system, for Standard Hoods (with fan motor) and Hoods without fan motor
922776	Extension for condensation tube, 37cm

Accessories

PNC Code	Description
Wall mounting kits	
922643	Wall support for 6 GN 1/1 oven
922687	Kit to fix oven to the wall
Water treatment	
864388	External reverse osmosis filter for single tank Dishwashers with atmosphere boiler and Ovens
920004	Water filter with cartridge and flow meter for low steam usage (less than 2 hours of full steam per day)
920005	Water filter with cartridge and flow meter for medium steam usage
Other accessories	
922326	Universal skewer rack
922327	4 long skewers
922421	IoT module for OnE Connected (combi ovens, blast chiller/freezers, rack type DW) and Match (one IoT board per appliance - to connect oven to the blast chiller for Cook&Chill process).
922435	Connectivity router (WiFi and LAN)
922448	Baking tray with 4 edges in perforated aluminum, coated surface, 400x600x20mm
922449	Baking tray with 4 edges in aluminum, coated surface, 400x600x20mm
922451	Grease collection kit for GN 1/1-2/1 open base (2 tanks, open/close device for drain)
922452	Grease collection kit for ovens GN 1/1 & 2/1 (2 plastic tanks, connection valve with pipe for drain)
922453	Grease collection kit for stacked ovens 6 GN on 6 GN 1/1 - 2/1, with riser
922773	Water inlet pressure reducer

Recommended Detergents

PNC Code	Description
0S2394	C25 Rinse & Descale Tabs, phosphate-free, phosphorous-free, maleic acid-free, 50 tabs bucket
0S2395	C22 Cleaning Tabs, phosphate-free, phosphorous-free, 100 bags bucket