

Hood dishwasher



EN User manual *





*Original instructions

59566WN00- 2026.04

Foreword

 Read the following instructions, including the warranty terms before installing and using the appliance.

Visit our website www.electroluxprofessional.com and open the Support section to:

-  Register your product
 -  Get hints & tips of your product, service and repair information
-

The installation, use and maintenance manual (hereinafter Manual) provides the user with information necessary for correct and safe use of the appliance.

The following must not be considered a long and exacting list of warnings, but rather a set of instructions suitable for improving appliance performance in every respect and, above all, preventing injury to persons and animals and damage to property due to improper operating procedures.

All persons involved in appliance transport, installation, commissioning, use and maintenance, repair and disassembly must consult and carefully read this manual before carrying out the various operations, in order to avoid wrong and improper actions that could compromise the appliance's integrity or endanger people. Make sure to periodically inform the user regarding the safety regulations. It is also important to instruct and update personnel authorised to operate on the appliance, regarding its use and maintenance.

The manual must be available to operators and carefully kept in the place where the appliance is used, so that it is always at hand for consultation in case of doubts or whenever required.

If, after reading this manual, there are still doubts regarding appliance use, do not hesitate to contact the Manufacturer or the authorised Service Centre to receive prompt and precise assistance for better operation and maximum efficiency of the appliance. During all stages of appliance use, always respect the current regulations on safety, work hygiene and environmental protection. It is the user's responsibility to make sure the appliance is started and operated only in optimum conditions of safety for people, animals and property.



IMPORTANT

- The manufacturer declines any liability for operations carried out on the appliance without respecting the instructions given in this manual.
- The manufacturer reserves the right to modify the appliances presented in this publication without notice.
- No part of this manual may be reproduced.
- This manual is available in digital format by:
 - contacting the dealer or reference customer care;
 - downloading the latest and up to date manual on the web site www.electroluxprofessional.com;
- The manual must always be kept in an easily accessed place near the appliance. Appliance operators and maintenance personnel must be able to easily find and consult it at any time.

Contents

A	SAFETY INFORMATION	4
A.1	General information	4
A.2	General safety	4
A.3	Personal protection equipment	5
A.4	Water connection	5
A.5	Electrical connection	5
A.6	Appliance cleaning and maintenance	6
A.7	Machine disposal	6
B	WARRANTY	7
B.1	Warranty terms and exclusions	7
C	GENERAL SAFETY RULES	7
C.1	Introduction	7
C.2	Mechanical safety characteristics, hazards	7
C.3	Protection devices installed on the appliance	7
C.3.1	Guards	7
C.3.2	Safety devices	7
C.4	Safety signs to be placed on the appliance or near its area	7
C.5	Instructions for use and maintenance	8
C.6	Reasonably foreseeable improper use	8
C.7	End of use	8
C.8	Residual risks	8
D	GENERAL INFORMATION	9
D.1	Introduction	9
D.2	Definitions	9
D.3	Machine and Manufacturer's identification data	9
D.4	Appliance identification	10
D.4.1	How to identify the technical data	10
D.4.2	How to interpret the factory description	10
D.4.3	How to interpret the type reference	10
D.5	Responsibility	10
D.6	Copyright	11
D.7	Keeping the manual	11
D.8	Recipients of the manual	11
E	NORMAL USE	11
E.1	Correct use	11
E.2	Characteristics of personnel enabled to operate on the appliance	11
E.3	Basic requirements for appliance use	11
F	TECHNICAL DATA	11
F.1	Main technical characteristics	11
G	PRODUCT DESCRIPTION	13
G.1	Machine overview	13
H	CONTROL PANEL DESCRIPTION	14
H.1	Control panel description	14
H.2	Basic Controls	14
I	OPERATION	15
I.1	Starting	15
I.2	Loading dishes on racks	15
I.3	Type of racks and loading	16
I.4	Operation	16
I.5	Delime cycle (not available for all models)	17
I.6	Wash cycles	17
I.7	Hood type dishwasher with incorporated continuous water softener	17
I.7.1	Salt container	18
I.7.2	How to fill the salt container	18
J	DAILY CLEANING	18
J.1	Appliance cleaning	18
J.2	End of service and daily internal cleaning	19
J.2.1	Cleaning the nozzle jets	20
K	MAINTENANCE	20
K.1	Maintenance intervals	20
K.1.1	Preventive Maintenance	20
K.2	Maintenance frequency	20
K.3	Periods of non-use	20
K.4	Boiler drainage	21
K.5	Machine disposal	21
L	TROUBLESHOOTING	21
L.1	General troubleshooting	21
L.2	Alarms	23

A SAFETY INFORMATION

A.1 General information

These appliance is intended to be used for commercial applications, for example in kitchens of restaurant, canteens, hospitals. It must be used for washing or drying (depending on the model) plates, dishes, glassware, cutlery and similar articles.

To ensure safe use of the appliance and a proper understanding of the manual it is necessary to be familiar with the terms and typographical conventions used in the documentation. The following symbols are used in the manual to indicate and identify the various types of hazards:



WARNING

Danger for the health and safety of operators.



WARNING

Danger of electrocution - dangerous voltage.



CAUTION

Risk of damage to the appliance or the product.



IMPORTANT

Important instructions or information on the product



Equipotentiality



Read the instructions before using the appliance







Clarifications and explanations

A.2 General safety

- The appliance must not be used by people (including children) with limited physical, sensory or mental abilities or without experience and knowledge of it, unless instructed in its use and supervised by those responsible for their safety.
 - Do not let children play with the appliance.
 - Keep all packaging and detergents away from children.
 - Cleaning and user maintenance shall not be made by children without supervision.
- For suitable personal protection equipment, refer to chapter “A.3 *Personal protection equipment*”.
- Several illustrations in the manual show the machine, or parts of it, without guards or with guards removed. This is purely for explanatory purposes. Do not use the machine without the guards or with the protection devices deactivated.
- Do not remove, tamper with or make illegible the safety, danger and instruction signs and labels on the machine.
- Do not remove or tamper with the machine’s safety devices.
- Unauthorised personnel must not enter the work area.
- Remove any flammable products or items from the work area.

A.3 Personal protection equipment

Summary table of the Personal Protection Equipment (PPE) to be used during the various stages of the appliance's service life.

Stage	Protective garments 	Safety footwear 	Gloves 	Glasses 	Safety helmet 
Transport	—	●	○	—	○
Handling	●	●	○	—	—
Unpacking	○	●	○	—	—
Installation	○	●	● ¹	—	—
Normal use	●	●	● ²	○	—
Adjustments	○	●	—	—	—
Routine cleaning	○	●	● ¹⁻³	○	—
Extraordinary cleaning	○	●	● ¹⁻³	○	—
Maintenance	○	●	○	—	—
Dismantling	○	●	○	○	—
Scrapping	○	●	○	○	—
Key:					
●	PPE REQUIRED				
○	PPE AVAILABLE OR TO BE USED IF NECESSARY				
—	PPE NOT REQUIRED				

1. During these operations, gloves must be cut-resistant. Failure to use the personal protection equipment by operators, specialized personnel or users can involve exposure to harm to health (depending on the model).

2. During these operations, gloves must be heatproof and suitable for contact with water and the substances used (refer to the safety data sheet of the substances used for the information regarding the required PPE). Failure to use the personal protection equipment by operators, specialised personnel or users can involve exposure to chemical risk and cause possible harm to health (depending on the model).

3. During these operations, gloves must be suitable for contact with chemical substances used (refer to the safety data sheet of the substances used for information regarding the required PPE). Failure to use the personal protection equipment by operators, specialized personnel or users can involve exposure to chemical risk and cause possible harm to health (depending on the model).

A.4 Water connection

- The operating water pressure (minimum and maximum) must be between:
 - 0.5 bar [50 kPa] and 7 bar [700 kPa];
- Make sure that there are no visible water leaks during and after the first use of the machine.

A.5 Electrical connection

- If the power cable is damaged it must be replaced by the Customer Care Service or in any case by specialised personnel, in order to prevent any risk.

A.6 Appliance cleaning and maintenance

- Depending on the model and type of electric connection, during maintenance operations, the cable and plug must be kept in a visible position by the operator carrying out the work.
- Do not touch the appliance with wet hands or feet or when barefoot.
- Do not remove the safety guards.
- Use a ladder with suitable protection for work on appliances with high accessibility.
- Respect the requirements for the various routine and extraordinary maintenance operations. Non compliance with the instructions can create risks for personnel.

Ordinary maintenance

- Do not clean the appliance with a water jet, a high pressure cleaner or a steam cleaner.

A.7 Machine disposal

- Work on the electrical equipment must only be carried out by a specialised personnel, with the power supply disconnected.
- Dismantling operations must be carried out by specialised personnel.
- Make the appliance unusable by removing the power cable and any compartment closing devices, to prevent the possibility of someone becoming trapped inside.
- Refer to “A.3 *Personal protection equipment*” for suitable personal protection equipment.
- When scrapping the machine, the “CE” marking, this manual and other documents concerning the appliance must be destroyed.



IMPORTANT

Save these instructions carefully for further consultation by the various operators.

B WARRANTY

B.1 Warranty terms and exclusions

If the purchase of this product includes warranty coverage, warranty is provided in line with local regulations and subject to the product being installed and used for the purposes as designed, and as described within the appropriate equipment documentation.

Warranty will be applicable where the customer has used only genuine spare parts and has performed maintenance in accordance with Electrolux Professional user and maintenance documentation made available in paper or electronic format.

Electrolux Professional strongly recommends using Electrolux Professional approved cleaning, rinse and descaling agents to obtain optimal results and maintain product efficiency over time.

The Electrolux Professional warranty does not cover:

- service trips cost to deliver and pick up the product;
- installation;
- training on how to use/operate;
- replacement (and/or supply) of wear and tear parts unless resulting from defects in materials or workmanship reported within one (1) week from the failure;
- correction of external wiring;
- correction of unauthorized repairs as well as any damages, failures and inefficiencies caused by and/or resulting from:
 - insufficient and/or abnormal capacity of the electrical systems (current/voltage/frequency, including spikes and/or outages);
 - inadequate or interrupted water supply, steam, air, gas (including impurities and/or other that does not comply with the technical requirements for each appliance);
 - plumbing parts, components or consumable cleaning products that are not approved by the manufacturer;

- customer's negligence, misuse, abuse and/or non-compliance with the use and care instructions detailed within the appropriate equipment documentation;
 - improper or poor: installation, repair, maintenance (including tampering, modifications and repairs carried out by third parties not authorized) and modification of safety systems;
 - Use of non-original components (e. g.: consumables, wear and tear, or spare parts);
 - environment conditions provoking thermal (e. g. overheating/freezing) or chemical (e. g. corrosion/oxidation) stress;
 - foreign objects placed in- or connected to- the product;
 - accidents or force majeure;
 - transportation and handling, including scratches, dents, chips, and/or other damage to the finish of the product, unless such damage results from defects in materials or workmanship and is reported within one (1) week of delivery unless otherwise agreed;
- product with original serial numbers that have been removed, altered or cannot be readily determined;
 - replacement of light bulbs, filters or any consumable parts;
 - any accessories and software not approved or specified by Electrolux Professional.

Electrolux Professional warranty will be void and manufacturer shall have no liability related thereto in case of any modification of the product or related hardware/software/programming.

Warranty does not include scheduled maintenance activities (including the parts required for it) or the supply of cleaning agents unless specifically covered within any local agreement, subject to local terms and conditions.

Check on Electrolux Professional website the list of authorized customer care.

C GENERAL SAFETY RULES

C.1 Introduction

The machines are provided with electric and/or mechanical safety devices for protecting workers and the machine itself.

Therefore the user must not remove or tamper with such devices. The Manufacturer declines any liability for damage due to tampering or their non-use.

C.2 Mechanical safety characteristics, hazards

The machine does not have sharp edges or protruding parts. The guards for the moving and live parts are fixed to the cabinet with screws, to prevent accidental access.

C.3 Protection devices installed on the appliance

C.3.1 Guards

The guards on the appliance are:



- fixed guards (e.g. casings, covers, side panels, etc.), fixed to the appliance and/or frame with screws or quick-release connectors that can only be removed or opened with tools;
- interlocked movable guards (door) for access inside the appliance;
- appliance electrical equipment access doors, made from hinged panels openable with tools. The door must not be opened when the appliance is connected to the power supply.



C.3.2 Safety devices

The appliance has:

- interlocks on the front panels giving access to inside the appliance;

C.4 Safety signs to be placed on the appliance or near its area

Prohibition	Meaning
	do not oil, lubricate, repair and adjust moving parts
	do not remove the safety devices
	do not use water to extinguish fires (placed on electrical parts)

Danger	Meaning
	danger of crushing hands
	caution, hot surface
	danger of electrocution (shown on electrical parts with indication of voltage)

C.5 Instructions for use and maintenance

Risks mainly of a mechanical, thermal and electrical nature exist in the appliance. Where possible the risks have been neutralised:

- directly, by means of adequate design solutions.
- indirectly by using guards, protection and safety devices.

Any anomalous situations are signalled on the control panel display.

During maintenance several risks remain, as these could not be eliminated, and must be neutralised by adopting specific measures and precautions.

Do not carry out any checking, cleaning, repair or maintenance operations on moving parts. Workers must be informed of this prohibition by means of clearly visible signs.

To guarantee appliance efficiency and correct operation, periodical maintenance must be carried out according to the instructions given in this manual.

Make sure to periodically check correct operation of all the safety devices and the insulation of electrical cables, which must be replaced if damaged.

C.6 Reasonably foreseeable improper use

Improper use is any use different from that specified in this manual. During appliance operation, other types of work or activities deemed improper and that in general can involve risks for the safety of operators and damage to the appliance are not allowed. Reasonably foreseeable improper use includes:

- lack of appliance maintenance, cleaning and periodical checks;
- structural changes or modifications to the operating logic;
- tampering with the guards or safety devices;
- failure to use personal protection equipment by operators, specialised personnel and maintenance personnel;
- failure to use suitable accessories (e.g. use of unsuitable equipment or ladders);
- keeping combustible or flammable materials, or in any case materials not compatible with or pertinent to the work, near the appliance;
- wrong appliance installation;
- placing in the appliance any objects or things not compatible with its use, or that can damage the appliance, cause injury or pollute the environment;
- climbing on the appliance;
- non-compliance with the requirements for correct appliance use;
- other actions that give rise to risks not eliminable by the Manufacturer.

C.7 End of use

When the appliance is no longer to be used, make it unusable by removing the mains power supply wiring.

C.8 Residual risks

The appliance has several risks that were not completely eliminated from a design standpoint or with the installation of adequate protection devices. Nevertheless, through this manual the Manufacturer has taken steps to inform operators of such risks, carefully indicating the personal protection equipment to be used by them. In order to reduce the risks, provide for sufficient spaces while installing the unit. To preserve these conditions, the areas around the appliance must always be:

- kept free of obstacles (e.g. ladders, tools, containers, boxes, etc.);
- clean and dry;
- well lit.

For the Customer's complete information, the residual risks remaining on the appliance are indicated below: such situations are deemed improper and therefore strictly forbidden.

Residual risk	Description of hazardous situation
Slipping or falling	The operator can slip due to water or dirt on the floor
Burns/abrasions (e.g. heating elements, cold pan, cooling circuit plates and pipes)	The operator deliberately or unintentionally touches some components inside the appliance without using protective gloves.
Stab wounds	The operator deliberately or unintentionally touches some components with sharp edges during the appliance cleaning without using protective gloves.
Burns	The operator deliberately or unintentionally touches some components inside the appliance or dishes at the outfeed without using gloves or without allowing them to cool.
Shearing of upper limbs	The operator violently closes the front panels.
Electrocution	Contact with live parts during maintenance operations carried out with the electrical panel powered
Falling from above	The operator intervenes on the appliance using unsuitable systems to access the upper part (e.g. rung ladders, or climbs on it)
Crushing or injury	The specialised personnel may not correctly fix the control panel when accessing the technical compartment. The panel could close suddenly.
Crushing or shearing	Possible risk of injury to upper limbs during the hood closing operation.
Tipping of loads	When handling the appliance or the packing containing it, using unsuitable lifting systems or accessories or with the unbalanced load
Chemical	Contact with chemical substances (e.g. detergent, rinse aid, scale remover, etc.) without taking adequate safety precautions. Therefore always refer to the safety cards and labels on the products used.

**IMPORTANT**

In case of a significant anomaly (e.g. short circuits, wires coming out of the terminal block, motor breakdowns, worn electrical cable sheathing, etc.) the operator must immediately deactivate the appliance.

D GENERAL INFORMATION**D.1 Introduction**

This manual contains information relevant to various appliances. The product images in this guide are only an example.

The drawings and diagrams given in the manual are not in scale. They supplement the written information with an outline, but are not intended to be a detailed representation of the appliance supplied.

The numerical values given on the appliance installation diagrams refer to measurements in millimeters and/or inches.

D.2 Definitions

Listed below are the definitions of the main terms used in the manual. It is advisable to read them carefully before use.

Operator	machine installation, adjustment, use, maintenance, cleaning, repair and transport personnel.
Manufacturer	Electrolux Professional SpA or any other service centre authorised by Electrolux Professional SpA.
Operator for normal machine use	an operator who has been informed and trained regarding the tasks and hazards involved in normal machine use.
Customer Care service or specialised technician	an operator instructed/trained by the Manufacturer and who, based on his professional and specific training, experience and knowledge of the accident-prevention regulations, is able to appraise the operations to be carried out on the machine and recognise and prevent any risks. His professionalism covers the mechanical, electrotechnical and electronics fields.
Danger	source of possible injury or harm to health.
Hazardous situation	any situation where an operator is exposed to one or more hazards.
Risk	a combination of probabilities and risks of injury or harm to health in a hazardous situation.
Protection devices	safety measures consisting of the use of specific technical means (guards and safety devices) for protecting operators against risks.
Guard	an element of a machine used in a specific way to provide protection by means of a physical barrier.
Safety device	a device (other than a guard) that eliminates or reduces the risk; it can be used alone or in combination with a guard.
Customer	the person who purchased the machine and/or who manages and uses it (e.g. company, entrepreneur, firm).
Emergency stop device	a group of components intended for the emergency stop function; the device is activated with a single action and prevents or reduces damage to persons/machines/property/animals.
Electrocution	an accidental discharge of electric current on a human body.

D.3 Machine and Manufacturer's identification data

An example of the marking or dataplate on the machine is given below:

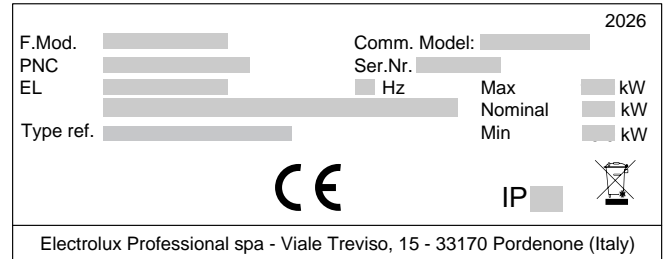

The dataplate gives the product identification and technical data; listed below is the meaning of the various information given on it.

F.Mod.	factory description of product
Comm.Model	commercial description
PNC	production number code
Ser.No.	serial number
400V 3N~	power supply voltage
230V 3~ - 230V 1N~	electric convertibility
Hz	power supply frequency
12.9 kW	max. power
9.9 kW	nominal power
6.9 kW	min. power
IPX25	dust and water protection rating
Type ref.	list of acronyms used to identify the type of machine, uniquely
CE	CE marking
Electrolux Professional SpA Viale Treviso 15 33170 Pordenone Italy	manufacturer

The dataplate is located on the right side panel of the equipment.

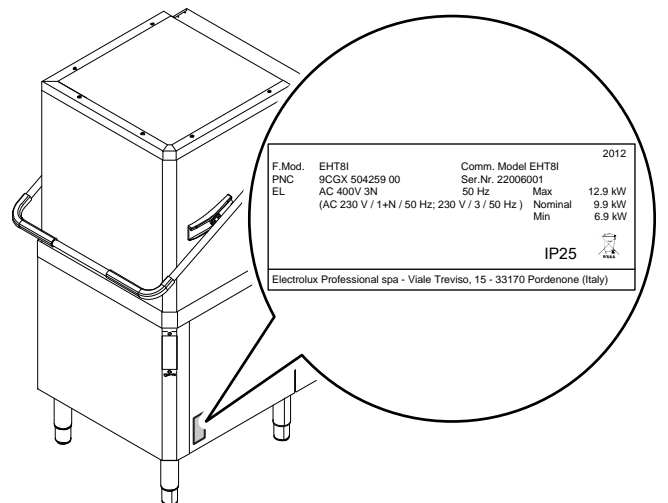



WARNING

Do not remove, tamper with or make the machine marking illegible.



IMPORTANT

When scrapping the machine, the marking must be destroyed.



NOTE!

Refer to the data given on the machine marking for relations with the Manufacturer (e.g. when ordering spare parts, etc.).

D.4 Appliance identification

D.4.1 How to identify the technical data

To identify the technical data, read the factory description of the product (F. Mod.) on the dataplate, identify the main machine data and consult "Main technical characteristics, performance and consumption".

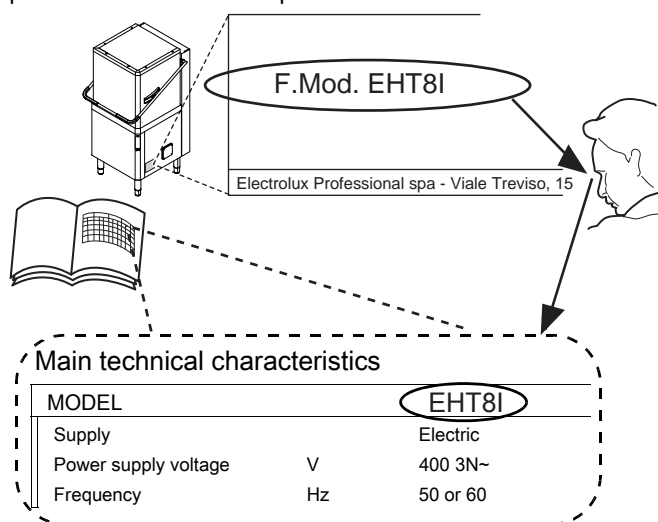

D.4.2 How to interpret the factory description

The factory description on the dataplate has the following meaning (some examples are given below):

Single-Skin version						
(1)	(2)	(3)	(4)	(5)	(6)	(7)
N	HT	8	WS	G		
E	HT	8	M			
Z	HT	8	L	G	UK	
V	HT	7	G			

Double-Skin version						
(1)	(2)	(3)	(4)	(5)	(6)	(7)
Z	HT	8	I	E	L	G
E	HT	8	T	I	E	L
V	HT	7	I	G		

Variable description

(1) Brand	E = Electrolux, Z = Zanussi, N = To brand, K = Kipro, A = Alpeninox, H = Hakpro, KXT = Klumaier X Tanner, V = Veetsan
(2) Machine type	HT = Hood Type

Variable description (cont'd.)

(3) Racks/hour	8 = 80 racks/hour 7 = 72 racks/hour
(4...7) Appliance equipment	T = automatic, I = double skin hood, E = Energy Saving Device, L = delime cycle, G = detergent pump + rinse aid pump + drain pump, DD = detergent pump, WS = water softener, M = marine, USPH = marine-USPH, UK = UK market, 6 = 60 Hz, S = solid detergent, AUS = Australian market.

D.4.3 How to interpret the type reference

The type reference description on the dataplate has the following meaning.

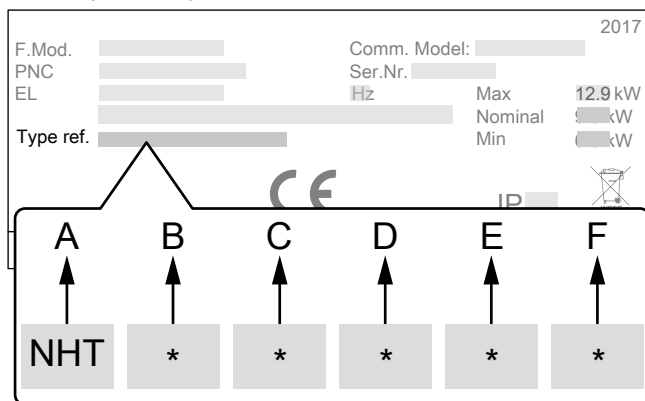

Legend

A	Type of appliance • Hood type dishwasher
B	Type of rinsing • 0 = without rinse pump • 1 = with rinse pump
C	Water treatment • 0 = without water softener • 1 = with water softener
D	Type of hood • 0 = manual hood • 1 = automatic hood
E	Energy Saving Device [ESD] • 0 = without ESD • 1 = with ESD
F	Heating element in the boiler • 0 = single heating element • 1 = double heating element

D.5 Responsibility

The Manufacturer declines any liability for damage and malfunctioning caused by:

- non-compliance with the instructions contained in this manual;
- repairs not carried out in a workmanlike fashion, and replacements with parts different from those specified in the spare parts catalogue (the fitting and use of non-original spare parts and accessories can negatively affect appliance operation and invalidates the original manufacturer warranty);
- operations carried out by non-specialised personnel;
- unauthorized modifications or operations;
- missing, lack or inadequate maintenance;
- improper appliance use;
- unforeseeable extraordinary events;
- use of the appliance by uninformed and / or untrained personnel;

- non-application of the current provisions in the country of use, concerning safety, hygiene and health in the workplace.

The Manufacturer declines any liability for:

- damage caused by arbitrary modifications and conversions carried out by the user or the Customer;
- inaccuracies contained in the manual, if due to printing or translation errors.

The employer, workplace manager or service technician are responsible for identifying and choosing adequate and suitable personal protection equipment to be worn by operators, in compliance with regulations in force in the country of use.

Any supplements to the installation, use and maintenance manual the Customer receives from the Manufacturer will form an integral part of the manual and therefore must be kept together with it.

D.6 Copyright

This manual is intended solely for consultation by the operator and can only be given to third parties with the permission of Electrolux Professional.

D.7 Keeping the manual

The manual must be carefully kept for the entire life of the appliance, until scrapping. The manual must stay with the appliance in case of transfer, sale, hire, granting of use or leasing.

D.8 Recipients of the manual

This manual is intended for:

- the employer of machine users and the workplace manager
- operators for normal machine use
- specialised technicians - Customer Care service (see service manual).

E NORMAL USE

E.1 Correct use

Our machines are designed and optimized in order to obtain high performance and efficiency.

This equipment must only be used for its expressly designed purpose, i. e. washing dishes with water and specific detergents. Any other use is to be deemed improper.

E.2 Characteristics of personnel enabled to operate on the appliance

The Customer must make sure the personnel for normal appliance use are adequately trained and skilled in their duties. The operator must:

- read and understand the manual;
- receive adequate training and instruction for their duties in order to operate safely;
- receive specific training for correct appliance use.



IMPORTANT

The Customer must make sure his personnel have understood the instructions received and in particular those regarding work hygiene and safety in use of the appliance.

E.3 Basic requirements for appliance use

- Knowledge of the technology and specific experience in operating the appliance.
- Adequate general basic education and technical knowledge for reading and understanding the contents of the manual, including correct interpretation of the drawings, signs and pictograms.
- Sufficient technical knowledge for safely performing his duties as specified in the manual.
- Knowledge of the regulations on work hygiene and safety.

F TECHNICAL DATA

F.1 Main technical characteristics

Model		NHT8/EHT8/ KHT8/HHT8/ XHT8/ZHT8/ VHT7/	ZHT8/AHT8/ EHT8/NHT8/ HHT8/XHT8/ VHT7/	EHT8M/ EHT8IUSPH5	EHT8M6/ EHT8IUSPH6	EHT8TIL.../ ZHT8TIL...
Supply voltage: convertible to single-phase version		400V 3N~ 230V 3~ 230V 1N~	400V 3N~ ¹ 230V 3~ ¹ 230V 1N~ ¹	400V 3~ — —	440V 3~ — —	400V 3N~ 230V 3~ 230V 1N~
Frequency	Hz	50	50 or 60	50	60	50
Max. power	kW	12.9 ²	12.9 ²	12.9 ²	12.9 ²	12.9 ²
Power absorbed as factory setting		9.9	9.9	9.9	9.9	9.9
Power absorbed with water supply at 65°C [149°F]		6.9 ³	6.9 ³	—	—	6.9 ³
Boiler heating elements	kW	9.0	9.0	9.0	9.0	9.0
Tank heating elements	kW	3.0	3.0	3.0	3.0	3.0
Water supply pressure	bar [kPa]	0.5 bar [50 kPa] 7 bar [700 kPa]	0.5 bar [50 kPa] 7 bar [700 kPa]	0.5 bar [50 kPa] 7 bar [700 kPa]	0.5 bar [50 kPa] 7 bar [700 kPa]	0.5 bar [50 kPa] 7 bar [700 kPa]
Water supply temperature: — for models without ESD — for models with ESD	°C [°F]	10-65 [50-149] —	10-65 [50-149] 10-20 [50-68]	10-65 [50-149] —	10-65 [50-149] —	10-65 [50-149] 10-20 [50-68]

Model		NHT8/EHT8/ KHT8/HHT8/ XHT8/ZHT8/ VHT7/	ZHT8/AHT8/ EHT8/NHT8/ HHT8/XHT8/ VHT7/	EHT8M/ EHT8IUSPH5	EHT8M6/ EHT8IUSPH6	EHT8TIL.../ ZHT8TIL...
Water supply hardness for models without incorporated continuous water softener	°f/°d/ °e	14/8/10 max	14/8/10 max	14/8/10 max	14/8/10 max	14/8/10 max
Water supply hardness for models with incorporated water softener	°f/°d/ °e	53.4/30/ 35.7 max	53.4/30/ 35.7 max	53.4/30/ 35.7 max	53.4/30/ 35.7 max	53.4/30/ 35.7 max
Electric conductivity of water for models without incorporated continuous water softener	µS/ cm	<400	<400	<400	<400	<400
Concentration of chlorides in water	ppm	<20	<20	<20	<20	<20
Rinse cycle water consumption	l	2.0 ⁴	2.0 ⁴	2.0	2.0	2.0
Boiler capacity	l	12	12	12	12	12
Tank capacity	l	24	24	24	24	24
Cycle duration in "High Productivity" mode ⁵	sec.	45-84-150 50-84-150 (VHT7G)	45-84-150 ⁶ 50-84-150 (VHT7IG)	45-84-150	45-84-150	45-84-150 ⁶
Cycle duration in "NSF/ANSI3" compliant mode ⁵	sec.	57-84-150	57-84-150 ⁶	57-84-150	57-84-150	57-84-150 ⁶
Legal noise level Leq ⁷	dB[A]	LpA:68dB KpA:1.5dB	LpA:68dB KpA:1.5dB	LpA:68dB KpA:1.5dB	LpA:68dB KpA:1.5dB	LpA:68dB KpA:1.5dB
Protection rating		IPX25	IPX25	IPX25	IPX25	IPX25
Net weight for models without [with] ESD	kg	106 [-]	117 [150]	117 [-]	117 [-]	119 [152]
Power supply cable		H07RN-F	H07RN-F	H07RN-F	H07RN-F	H07RN-F
Supply cord diameter (min. - max. value)	mm	18 - 25	18 - 25	18 - 25	18 - 25	18 - 25
Latent heat without [with] ESD	kWh	0.5 [-]	0.5 [0.35]	0.5 [-]	0.5 [-]	0.5 [0.35]
Sensible heat without [with] ESD	kWh	2 [-]	2 [1.49]	2 [-]	2 [-]	2 [1.49]

1. For the model EHT8IELG6: 380-400V 3N~ convertible 220-230V 3~ or 220-230V 1N~.
2. If activated by software, coincidence of tank and boiler heating elements.
3. Activatable via software only by a specialized technician.
4. For models VHT7G and VHT7IG 2.3 liters.
5. With water supply temperature at 65°C [149°F].
6. In models with Energy Saving Device (ESD) cycle duration is extended by 11 seconds.
7. The noise emission values have been obtained according to EN ISO 11204.

	380 – 415V 3N		400 – 440V 3		220 – 240V 3		220 – 240V 1N	
	C	S	C	S	C	S	C	S
6.9 kW	5x2.5 mm ²	16A 3P + N	5x2.5 mm ²	16A 3P	4x4 mm ²	20A 3P	3x6 mm ²	40A 1P + N
9.9 kW	5x2.5 mm ²	20A 3P + N	4x2.5 mm ²	20A 3P	4x6 mm ²	32A 3P	3x10 mm ²	60A 1P + N
12.9 kW	5x4 mm ²	32A 3P + N	4x4 mm ²	25A 3P	4x10 mm ²	50A 3P	3x10 mm ²	70A 1P + N

C = Power supply cable
S = On/Off switch



NOTE!

Standard cycle time may vary should the inlet water temperature and/or the boiler heating elements be different from that indicated above.

G PRODUCT DESCRIPTION

G.1 Machine overview

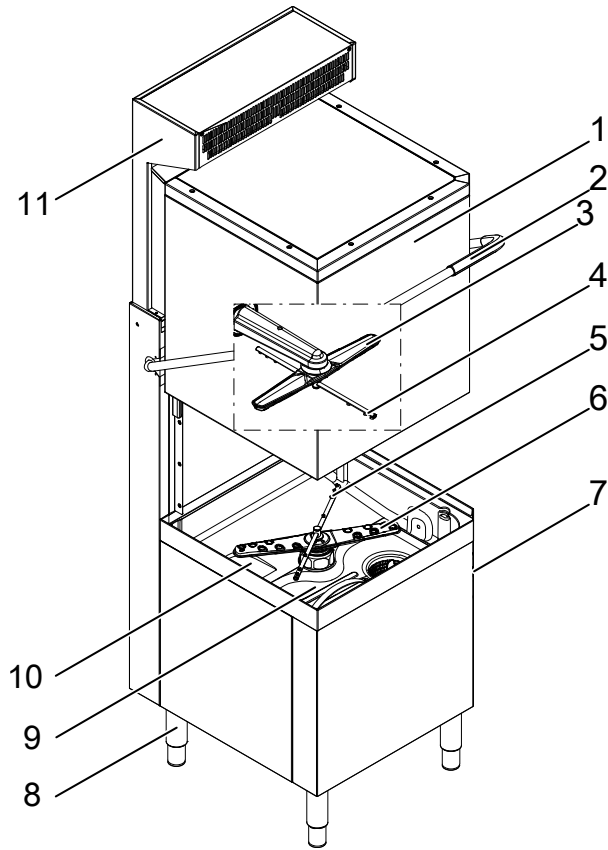

1	Hood
2	Handle
3	Upper washer arm
4	Upper rinse arm
5	Lower rinse arm
6	Lower washer arm
7	Control panel
8	Adjustable feet
9	Wash tank filtering system (depending on the model)
	<ul style="list-style-type: none"> • Version "A" • Version "B" • Version "C"

10	Salt container (depending on the model)
11	Energy Saving Device [ESD] (depending on the model)

Wash tank filtering system "A"

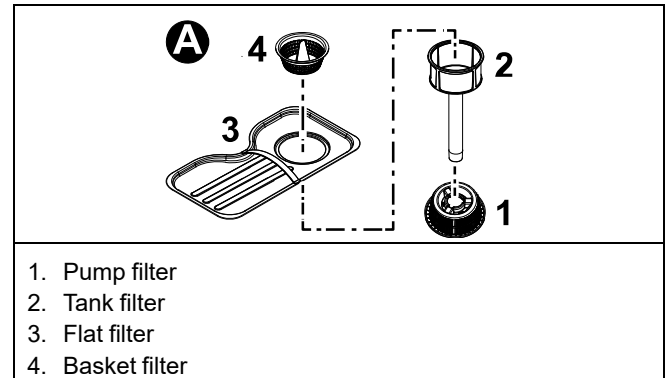

Wash tank filtering system "B"

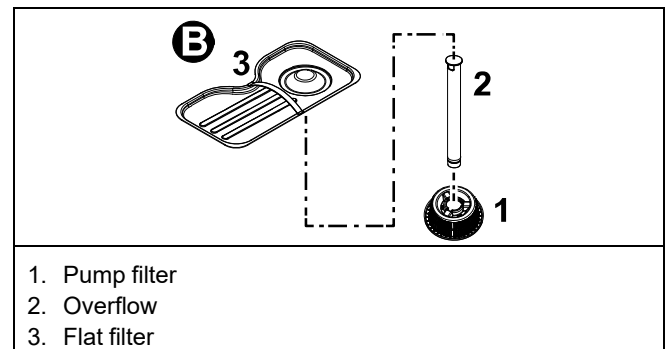

Wash tank filtering system "C"

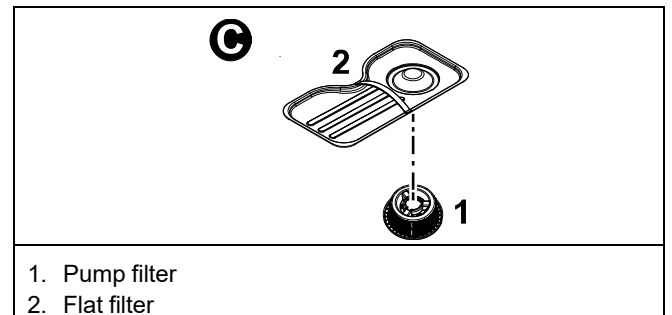

H CONTROL PANEL DESCRIPTION

H.1 Control panel description

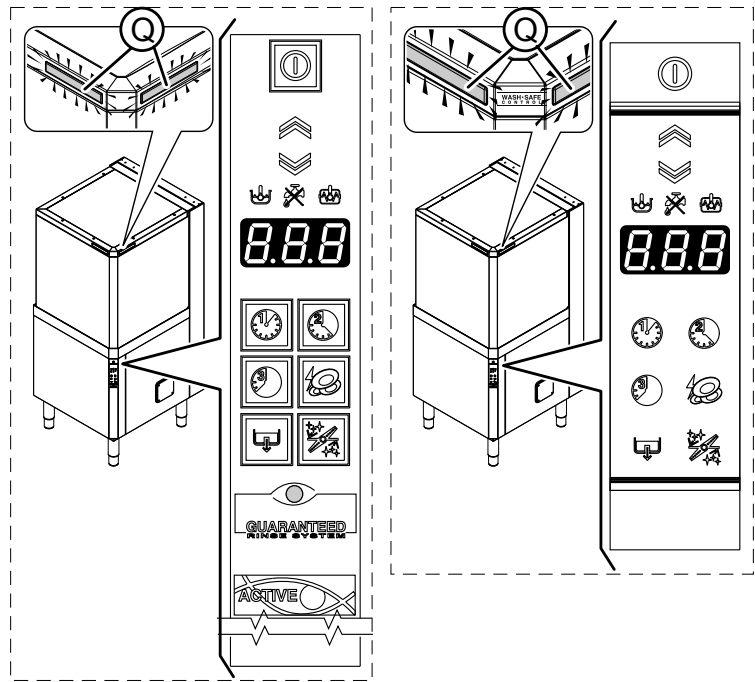
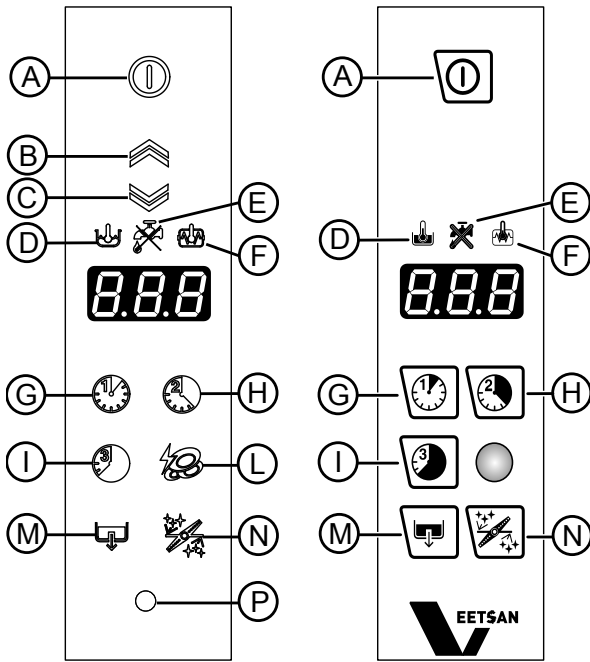

A	On / Off
B	Open hood
C	Close hood
D	"Tank temperature" indicator light
E	"Water tap" indicator light
F	"Boiler temperature" indicator light
G	Wash cycle 1
H	Wash cycle 2
I	Wash cycle 3
L	High Productivity or NSF/ANSI 3 compliant
M	Drain / self-cleaning cycle
N	"Delime" cycle
P	ACTIVE / WASH SAFE CONTROL
Q	LED bar

Active/Wash Safe Control indicator



In the **Active/Wash Safe Control** models a special device checks the temperature of the rinse phase. The **GUARANTEED RINSE SYSTEM [GRS]** is an automatic rinse time/temperature control system.

The **GUARANTEED RINSE SYSTEM** is active:

- during the wash cycle and the indicator light is OFF;
- during the rinse cycle and the indicator light comes on and is GREEN;
- at the end of the rinse cycle. The indicator light is GREEN if the rinse temperature and time have been carried out as per the programme, otherwise the indicator light is RED;
- upon opening the hood, the indicator light GOES OUT.



NOTE!

If the indicator light is RED, wait for a couple of minutes and then repeat the wash cycle.

H.2 Basic Controls

Described below are all the single buttons and functions available in the various control panel models listed above. Some functions are common to all models of the range, whereas others are available only on some versions.

On/Off

This button indicates equipment status: on or off. When the equipment is on, the button indicator is lit up.



Hood opening/closing (for automatic versions only)

These buttons open/close the hood, only in automatic versions.



Wash cycle 1

This button starts **Wash cycle 1**. When the cycle is selected, the button indicator is lit up. This cycle is recommended for washing not very dirty dishes.



Wash cycle 2

This button starts **Wash cycle 2**. When the cycle is selected, the button indicator is lit up. This cycle is recommended for washing normally dirty dishes.



Wash cycle 3

This button starts **Wash cycle 3**. When the cycle is selected, the button indicator is lit up. This cycle is recommended for washing very dirty dishes.



High Productivity or NSF/ANSI 3 compliant mode

This button is used to go from "High Productivity" wash mode to "NSF/ANSI3" compliant mode and vice versa.



Drain / self-cleaning cycle

This button starts a drain/self-cleaning cycle. When the cycle is selected, the button indicator is lit up.

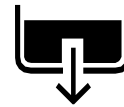

Delime cycle

This button is used to run a machine water circuit "delime" cycle with vinegar. When a cycle is selected, the corresponding button is lit up.



I OPERATION

I.1 Starting



NOTE!

Carry out a couple of cycles without dishes to flush out any industrial grease which has remained in the tank and piping.

- Open the water supply tap.
- Switch on at the mains.
- Raise the hood and check that all the components are in their correct position.
- Switch on the dishwasher by pressing the button the On/Off button.
- Close the hood and press On/Off button.



- The On/Off button lights up, indicating that the dishwasher is powered and that water is being introduced and heated. The word "FILL" is shown on the display during the entire filling and heating stage.



FILL



NOTE!

This dishwasher does the first tank filling through several consecutive hot rinse cycles, while the display shows the message FILL (flowing). This system let save up to 30% of time than traditional models.

- If the hood is opened during this stage the message "CLOSE" will appear on the display.



CLOSE

- The filling and heating stage has finished when the display shows the tank temperature.



55°C

- To display the boiler temperature during heating of the tank, raise the hood and press wash cycle 1 button.



- If the indicator "E" (refer to H.1 *Control panel description*) lights up, check that the water tap is open.



I.2 Loading dishes on racks

The appliance is suitable for washing dishes, glasses, cups, cutlery, containers and receptacles in plastic and/or steel used for preparing, cooking and serving; as well as a wide variety of ceramic and/or metal cooking utensils. However it is advisable not to wash decorated dishes or place silverware in contact with other metals.



IMPORTANT

The appliance does not remove burnt food deposits from dishes. Dishes with burnt-on food deposits should be cleaned mechanically/chemically before putting them in the dishwasher. Before inserting the racks in the machine, clear the dishes of any food residuals and rinse them with cold or warm water, at a max. temperature of 35°C [95°F], using a manual prewash spray.

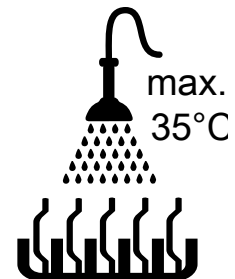

CAUTION

Failure to remove the residuals of detergent possibly used for manual prewash can cause malfunctioning of the dishwasher and compromise washing results.



IMPORTANT

This machine must only be used for washing dishes, containers, etc. (see above) do not use it to wash animals or food (e.g., fruit, vegetables, meat or fish).

I.3 Type of racks and loading

- **YELLOW** rack: for 18 plates with maximum diameter of 240 mm.

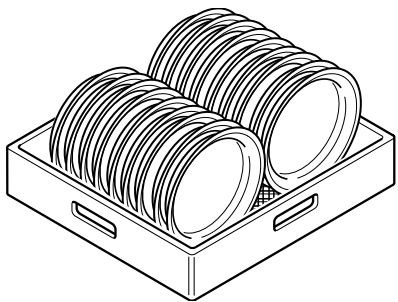

- **GREEN** rack: for 12 bowls with maximum diameter of 240 mm.

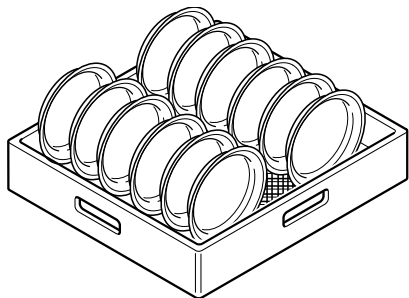

- **BLUE** rack for glasses: the glasses should be placed upside down.

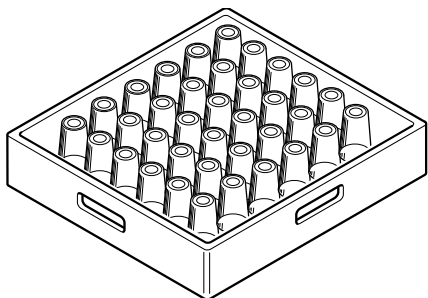

- **YELLOW** container for cutlery: insert 15 items, with the handles pointing downwards, in each container.

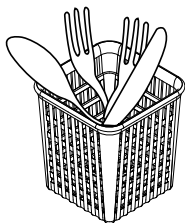

Available as accessories: dividers for glasses and rack for dishes with maximum diameter of 320 mm.



NOTE!

If only one type of dish rack is to be used, it is advisable to choose the GREEN rack.

I.4 Operation



IMPORTANT

- To guarantee sanitization of the dishes, wash at least 3 empty racks at lowest speed. This allows all the machine to reach the working temperature. Repeat the procedure if the machine is stopped or the hood is opened for a long time.
- During normal daily operations, make sure to change the water in the tank at least twice a day.

The filling and heating stage has finished when the display shows the tank temperature. The appliance is then ready for use.



- Leave the hood.

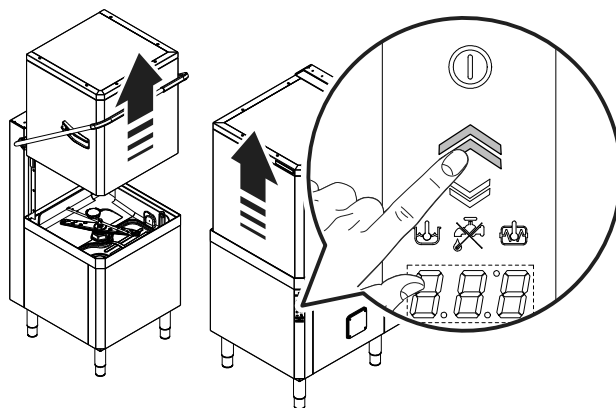

- Only for model without detergent pump, pour the required amount of detergent into the tank.
- Insert the rack containing the dirty dishes.
- Close the hood and select the suitable wash cycle; the corresponding indicator light comes on and the wash cycle starts:

Wash cycle	Type of dirty	Button
Cycle I	For lightly soiled dishes	
Cycle II (recommended)	For dirty dishes	
Cycle III	For very dirty dishes	

- To stop the wash cycle, just press the selected cycle button or lift the hood.
- To continue the wash cycle, just press the selected cycle button or close the hood. The cycle starts again from where it stopped.
- At the end of the wash, the dishwasher emits a series of beeps and "END" blinks on the display:

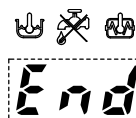

- Lift the hood and remove the rack containing the clean dishes.

In models with "Energy Saving Device" [ESD], before the message "END", the display shows a countdown for a few seconds:

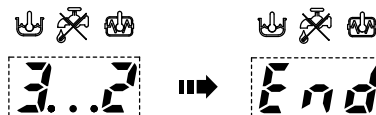

IMPORTANT

With automatic machines, the hood opens automatically at the end of the wash cycle.

High Productivity or NSF/ANSI 3 compliant mode

- Press and hold down (5 sec.) this button to switch the machine from "High Productivity" mode to "NSF/ANSI 3 compliant" mode and vice versa. This button is off when the machine is set in "NSF/ANSI 3 compliant" mode and lights up when the button is pressed and the machine is configured in "High Productivity" mode (factory default setting).





CAUTION

The use of “foaming/nonspecific” detergents or in any case detergents used in different ways from that prescribed by the manufacturer, can cause damage to the dishwasher and compromise the washing results.

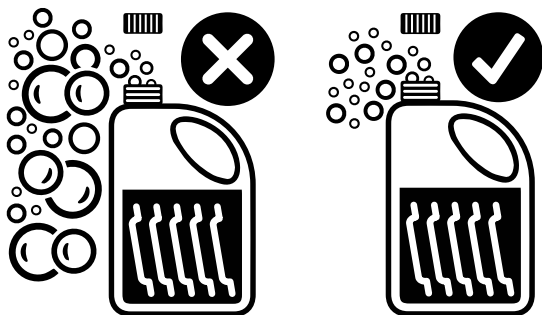

NOTE!

To obtain excellence washing performance, use detergent, rinse aid and descaling agent suggested by Electrolux Professional. In the Electrolux Professional web site, open the “Accessories and Consumables” web page and navigate into the dishwashing equipment tab to order most suitable detergents and accessories.

1.5 Delime cycle (not available for all models)

Press this button to run a machine water circuit delime cycle with vinegar.



CAUTION

Only use wine vinegar (with 6% of acetic acid) and not other descaling substances.



WARNING

Descaling with the use of chemical substances other than vinegar must only be done by a specialised personnel.

It is advisable to run this cycle according to that given in the table:

Water hardness			The Delime cycle should be run approximately every: ¹	Using cycle 2 for 30 cycles/day, the Delime cycle should be run approximately every: ¹
°f	°d	°e		
5	2.8	3.5	1500	50
10	5.6	7.0	750	25
15	8.4	10.5	510	17
20	11.2	14	380	13
25	14	17.5	300	10
30	16.8	21.1	250	8

1. Considering a rinse time according to the factory settings.

Proceed as follows:

1. Insert the Delime hose present in the machine, identified by an appropriate label, in a container with at least 2L of wine vinegar 6% (2L is the minimum amount of vinegar needed for a correct Delime cycle).

2. Remove the basket with dishes and remove the overflow.
3. Close the hood.
4. Activate the Delime cycle by pressing the Delime button for at least 5 seconds.



NOTE!

To cancel the Delime cycle, if accidentally activated, press at the same time the On/Off and Delime buttons for 5 seconds.

5. At the end of Delime cycle, the dishwasher sounds a series of beeps and “END” will flash on the display.
6. Refit the previously removed overflow.



IMPORTANT

The Delime cycle lasts about 1h 30 sec; during this phase the hood must not be opened and no other command can be activated until completion of the cycle in progress. If the machine is turned off during the Delime cycle, at the next restart the cycle will resume exactly from where it was interrupted, until its completion.

1.6 Wash cycles

The wash cycle includes a wash with hot water and detergent at a temperature of at least 55°C [131°F] (min. 66°C [150°F] for Marine USPH versions) and a rinse with hot water and rinse aid (min. 82°C [180°F]). This machine can operate in 2 modes, “High Productivity” and “NSF/ANSI 3 compliant”. When the machine is set in “High Productivity” mode, the parameters that define the cycle times and temperature set points are the standard parameters, whereas when the machine is set in “NSF/ANSI 3 compliant” mode, the parameters are such as to ensure the “NSF/ANSI 3 compliant” test (see times table).

Table of times — Standard cycle time in “High Productivity” mode (factory default setting)

45 ¹	84	150
50 ²	84	150

1. With supply water temperature at 65°C [149°F].
2. Only for model VHT7G and VHT7IG.

Table of times — Standard cycle time in “NSF/ANSI 3 compliant” mode (factory default setting)

57 ¹	84	150

1. With supply water temperature at 65°C [149°F].



NOTE!

In models with Energy Saving Device (ESD) cycle duration is extended by 12 seconds. A device lengthens the cycle time if the water in the boiler has not reached the minimum temperature for correct rinsing. The cycle times and the temperature may be personalised (e.g. increase of the rinse time and temperature). The cycle times should only be set by a specialised personnel.

1.7 Hood type dishwasher with incorporated continuous water softener



IMPORTANT

Unlike conventional water softeners, this continuous softener does not require machine stops for regenerating the resins.

These models have a continuous softener in the dishwasher water circuit. By means of special resins, this device removes the calcareous substances from the feed water, supplying decalcified water for washing.

For the continuous softener to work properly the resins must be regenerated periodically, with frequency depending on the

hardness of the water and the number of wash cycles carried out.

Autonomy of the full salt container according to the change in inlet water hardness

Water hardness			The salt container must be filled approximately every ¹ :	Using cycle 2 for 30 cycles/day, the salt container must be filled approximately every ¹ :
°f	°d	°e		
15	8.4	10.6	2700	90
20	11.2	14	2180	73
25	14	17.6	1575	53
30	16.9	21.1	1035	35
35	19.7	24.6	855	30
40	22.5	28.1	675	23
45	25.2	31.6	450	15
50	28.1	35.1	270	9

The factory setting of max. outlet water hardness is 10 °f/ 5.6 °d/ 7 °e.

1. Considering a rinse time according to the factory settings.

I.7.1 Salt container

The water can only be softened if there is salt in the special container. The salt container must be filled when the dishwasher is started the first time and whenever the message **SAL End** appears and an audible alarm sounds.

Wash cycles can be started just the same, even if the display signals no salt; in which case the water used for washing is not softened.



CAUTION

- Only use coarse salt with a purity level of 99.8% NaCl. The use of salt with a lower purity level can cause clogging of the salt container filter and malfunctioning of the water softener.
- Open the salt container only when the message **SAL End** is displayed. Opening the cap when the message **SAL End** is not displayed can cause spilling of the saline solution and compromise correct machine operation.

I.7.2 How to fill the salt container

- Lift the hood and switch off the dishwasher by pressing ON/Off button.



- Unscrew cap "A" of the salt container, turning it counterclockwise.

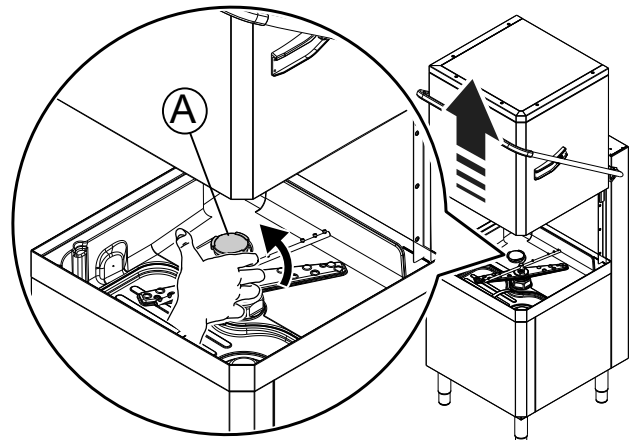

- Pour approx. 2 kg of coarse salt [NaCl] in container "A" (an amount sufficient to fill the salt container up to the rim) using the special funnel supplied.

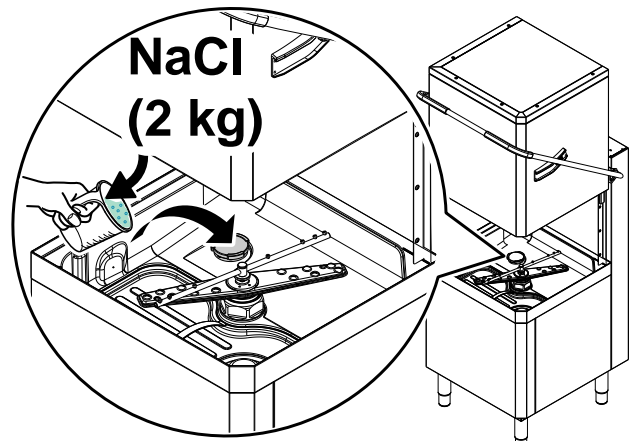

- Remove any traces of salt from the filling hole and the container thread of the closing cap.



NOTE!

The salt container always has water in it, therefore it is normal if water comes out during filling.

- Refit the cap of container "A", turning it clockwise and making sure it is tight.



CAUTION

Only salt may be placed in the salt container. Do not introduce any other chemical substances such as detergent, rinse aid or descaling agent, since these would inevitably damage the appliance. Such damage invalidates any warranty and relieves the manufacturer of all liability.



NOTE!

The message **SAL End** may appear for several wash cycles even after topping-up the salt, as the salt must circulate in the entire system. Correct operation of the dishwasher is not, however, affected.

J DAILY CLEANING



WARNING

Refer to chapter "A Safety Information".

J.1 Appliance cleaning

Cleaning must be carried out after every day of use. Use hot water, a neutral detergent/cleaner if necessary, and a soft brush or sponge. If another type of detergent is used, carefully follow the producer's instructions and observe the safety rules given in the information sheets provided with the product or substance.

In order to reduce the environmental impact of pollutants it is advisable to clean the appliance (externally and, where necessary, internally) with products that are more than 90% biodegradable.



CAUTION

Do not use steel wool or similar material to clean stainless-steel surfaces. Do not use detergents containing chlorine.



WARNING

When using chemicals, comply with the safety notes and dosage recommendations printed on the packaging. Refer to the chapter *A.3 Personal protection equipment* for handling chemical products.



J.2 End of service and daily internal cleaning

The appliance is designed to carry out an automatic cleaning cycle to help flush out any residues and to guarantee greater health and hygiene:

- Lift the hood and take out the rack containing the clean dishes.

In versions without supplementary filtering system

(see below picture, detail "B")

1. Remove the flat filter "1" and the overflow "2" if present.
2. Close the hood and select the drain cycle by pressing "Drain/Self cleaning" button.
3. At the end of the drain cycle, remove and clean the pump suction filter "3".

In versions with supplementary filtering system

(see below picture, detail "A")

1. Remove the basket filter "1", the flat filter "2".
2. Close the hood and select the drain cycle by pressing "Drain/Self cleaning" button.
3. Wait for almost 10 seconds and lift the hood again to remove the tank filter "3".
4. Close the hood to restart the drain cycle. At the end of the drain cycle, remove and clean the pump suction filter "4".

In versions with automatic hood and supplementary filtering system

(see below picture, detail "A")

1. Remove the basket filter "1", the flat filter "2".
2. Close the hood by pressing button "A".
3. Close the hood and select the drain cycle by pressing "Drain/Self cleaning" button.
4. Wait for almost 10 seconds and deactivate the drain cycle by pressing again the same button.

5. Lift the hood again by pressing button "B" to remove the tank filter "3".
6. Close the hood and select again restart the drain cycle by pressing the same button.
7. At the end of the drain cycle, remove and clean the pump suction filter "4".

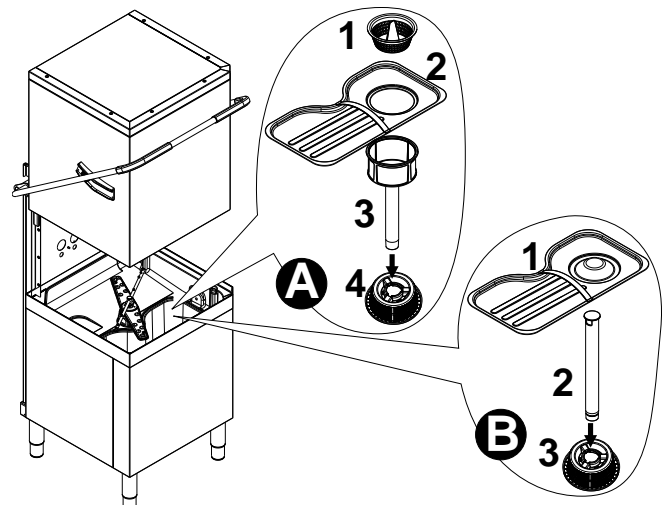

- The message "CLE" (CLEAN) will be displayed throughout the drain cycle.



- After a few minutes, 3 beeps indicate the end of the cleaning cycle and "END" blinks on the display.



- Switch off the dishwasher by pressing the On/Off button.



- Switch off at the mains.
- Close the water supply tap.
- Replace the filter and the overflow.

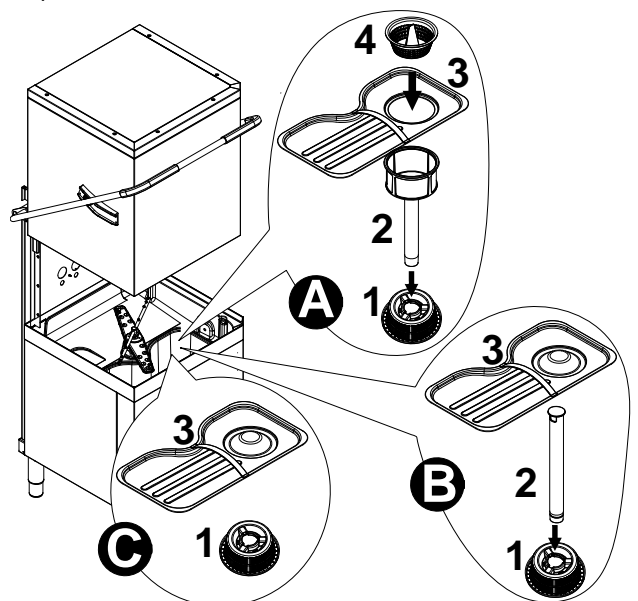

J.2.1 Cleaning the nozzle jets

- Remove the upper and lower wash arms "F" and rinse arms "I", unscrewing the ring nut "H".

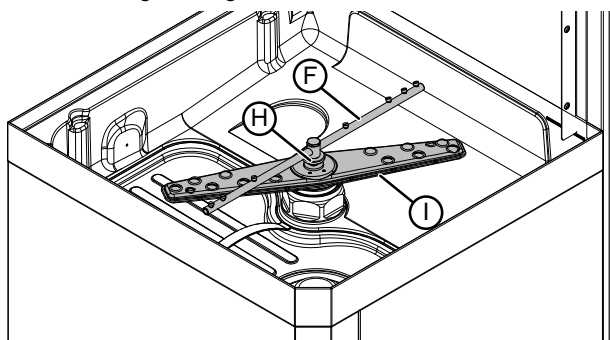

- Carefully clean the washing and rinse jets and clean everything with hot water and neutral detergent/deterasive, if necessary using a soft brush or sponge. Do not use sharp implements to clean the nozzle holes, which could otherwise be damaged.
- Replace the upper and lower wash arms and rinse arms.

K MAINTENANCE

K.1 Maintenance intervals

The inspection and maintenance intervals depend on the actual machine operating conditions and ambient conditions (presence of dust, damp, etc.), therefore precise time intervals cannot be given. In any case, careful and periodical machine maintenance is advisable in order to minimise service interruptions.

K.1.1 Preventive Maintenance

Preventive Maintenance reduces downtime and maximizes machines efficiency.

Customer Care Service can provide advice on the best maintenance plan to be purchased based on the intensity of use and the age of the equipment.

It is advisable to stipulate a preventive and scheduled maintenance contract with the Customer Care Service.

K.2 Maintenance frequency

To ensure constant appliance efficiency, it is advisable to carry out the checks with the frequency given in the following table:

Maintenance, inspections, checks and cleaning	Fre-quency	Respon-sability
Ordinary cleaning • general cleaning of appliance and surrounding area	Daily	Operator
Ordinary cleaning • Every week clean the wash and rinse jets removing inspection caps and clean it. Refer to section Wash and rinse arms maintenance.	Weekly	Operator
Ordinary cleaning • Every month descale the wash and rinse jets with vinegar.	Monthly	Operator
Ordinary cleaning • Every month descale the wash and rinse jets with scale remover.	Monthly	Service
Mechanical protection devices • check their condition and for any deformation, loosening or removed parts	Monthly	Service
Control • check the mechanical part, for cracks or deformation, tightening of screws: check the readability and condition of words, stickers and symbols and restore if necessary	Yearly	Service

Maintenance, inspections, checks and cleaning	Fre-quency	Respon-sability
Appliance structure • Descale the boiler, inside surfaces of the tank and the appliance piping.	Yearly	Service
Appliance structure • The internal hose of the rinse-aid and detergent peristaltic dispenser should undergo periodic maintenance.	Yearly	Service
Appliance structure • If present, clean the finned coil of the energy saving device.	Yearly	Service
Appliance structure • tightening of main bolts (screws, fixing systems, etc.) of appliance	Yearly	Service
Safety signs • check the readability and condition of safety signs	Yearly	Service
Electrical control panel • check the electrical components installed inside the electrical control panel. Check the wiring between the electrical panel and appliance parts.	Yearly	Service
Electrical connection cable and plug • check the connection cable (replace if necessary) and plug	Yearly	Service
General appliance overhaul • check all components, electrical equipment, corrosion, pipes...	Every 10 years ¹	Service

1. the appliance is designed and built for a duration of about 10 years. After this period of time (from commissioning) the appliance must undergo a general inspection and overhaul. Some examples of checks to be carried out are given below.

K.3 Periods of non-use

If the appliance is not going to be used for some time, take the following precautions:

- close the water supply tap(s), if present;
- disconnect the power supply or remove the plug from the power socket, if present;
- completely drain the tank(s);
- remove and carefully clean the filters;
- completely drain the boiler;
- completely drain the incorporated dispenser hoses. Remove them from the containers;

- carefully clean the internal parts of the appliance;
- clean the cabinet, going over all the stainless steel surfaces vigorously with a rag moistened with paraffin oil to create a protective film;
- leave the door or drawers, if present, open so that air can circulate inside, preventing the formation of unpleasant odours;
- periodically air the premises.



IMPORTANT

The warranty does not cover any damages caused by ice formations in the appliance pipes.

K.4 Boiler drainage

If the appliance is not to be used for a long time, empty out the boiler to prevent any malfunction and/or mildew and unpleasant odours.

- Close the hood.
- Press simultaneously and hold "Drain/Self Cleaning" button and button "L" (refer to H.1 *Control panel description*).
- A buzzer indicates the rinse pump activation and the display shows three blinking lines.
- Three beeps indicate the end of the cycle.

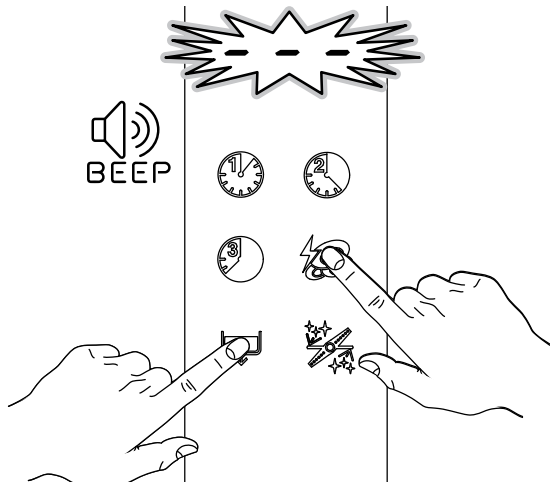

K.5 Machine disposal

At the end of the product's life cycle, make sure the equipment is not dispersed in the environment. The equipment must be disposed of in compliance with current regulations in the country of use.

All metal parts are in stainless steel (AISI 304) and removable. Plastic parts are marked with the letters of the material.



The symbol on the product indicates that this product should not be treated as domestic waste, but must be correctly disposed of in order to prevent possible negative consequences for the environment and the human health.

Regarding the recycling of this product, please contact the sales agent or dealer of your product, your Customer Care service or the appropriate waste disposal service.

L TROUBLESHOOTING

L.1 General troubleshooting

Anomaly	Type of anomaly	Possible causes	Actions
The dishwasher does not start	Blocking	The dishwasher is not connected to the main power supply.	Check if the appliance main circuit breaker is in ON position.
The dishwasher does not wash well.	Loss of performance.	No scrape action before putting dishes in the racks	Scrape dishes before putting them in the racks.
		The wash arms are clogged by solid food remains. Residual food has not been removed from dishes.	Check if the wash jets are clogged by solid food remains.
		The wash arms are not properly installed.	Check the integrity of the wash arms. Remove and fit again the wash arms.
		The dishes are not correctly placed in the racks.	Check if the dishes are correctly placed in the racks.
		The dosing of detergent is not correct.	Call detergent and rinse aid service centre.
		The detergent tank is empty.	Check that there is detergent in the container and if necessary top it up.
		Detergent pump does not work.	Call detergent and rinse aid service centre.
		The wash tank suction filter is dirty.	Clean wash tank suction filter thoroughly.

Anomaly	Type of anomaly	Possible causes	Actions
Glasses and dishes are not dried properly.	Loss of performance.	The container of rinse aid is empty.	Check that there is rinse-aid in the container and if necessary top it up.
		Rinse aid pump does not work.	Call detergent and rinse aid service centre.
		The rinse water temperature is too low.	Check if the rinse water temperature is between 82°C - 90°C. Call detergent and rinse aid service centre to set the temperature in according to the rinse aid specifications.
		Foamy detergent present in the wash tank.	Check if the dishes were not immersed in foamy detergent (e.g. hand wash detergent) before being put in the dishwasher. Only use "non-foaming" products for professional dishwashers.
Condensation on glasses.	Loss performance.	The container of rinse aid is empty.	Check that there is rinse-aid in the container and if necessary top up.
		Rinse aid pump does not work.	Call detergent and rinse aid service centre.
Stains on the glasses.	Loss of performance.	Foamy detergent present in the wash tank.	Only use "non-foaming" products for professional dishwashers.
		The dosing of rinse aid is not correct.	Call detergent and rinse aid service centre.
		the hardness of the water is too high or too low.	Adjust the amount of detergent and rinse aid. Call detergent and rinse aid service centre.
Excessive foam in the tank.	Loss performance.	Residuals of food or detergent, used for manual prewash, remains in the dishes.	Remove residuals of food or detergent from the dishes.
		Wash water temperature is too low.	Check if the water temperature of the wash module is between 55°C - 65°C. Call detergent and rinse aid service centre to set the temperature in according to the detergent specifications.
		Foamy detergent present in the wash tank.	Empty and refill the tank with water until the foam has been removed.
Smears or spots on the glasses.		Too much rinse-aid.	Reduce the amount of rinse-aid. Call detergent and rinse aid service centre.
Low pressure from wash arms.	Loss of performance	The tank filter is clogged. The wash pump filter is clogged. The water drainage hose is clogged. The wash pump does not work properly.	Clean the tank filter. Clean the wash pump filter. Call service centre. Call service centre.
Low pressure from rinse arms.	Loss of performance	The rinse arms are clogged. The water pressure after pressure reducer is less than 1 bar.	Clean the rinse arms. Call service centre.
The wash pump does not work.	Blocking	The wash pump is clogged.	Call service centre.
The drain pump does not work.	Loss of performance	The drain pump is clogged.	Call service centre.

Anomaly	Type of anomaly	Possible causes	Actions
The dishwasher is switched off, but the appliance continues to fill water.	Loss of performance	Inlet valve is damaged.	Close the water supply tap or taps and call service centre.
The display shows to close the hood.  Once closed the hood, the display shows the same anomaly.	Blocking	The magnetic switch hood does not work.	Call service centre.

If the fault persists after carrying out the above checks, contact the Customer Care Service, remembering to specify:

- A. the type of fault;
- B. the appliance PNC (product number code);
- C. the Ser. No. (appliance serial number).



IMPORTANT

The appliance PNC and serial number are essential for identifying the type of appliance and date of manufacture.



NOTE!

For detailed information about the troubleshooting see the complete user manual in the web site.

L.2 Alarms

Anomaly	Type of anomaly	Description	Possible causes	Actions
A1	Blocking Appliance stops	Lack of water	<ol style="list-style-type: none"> 1. The inlet water tap is closed. 2. The water inlet filter is clogged. 3. Too low pressure in hydraulic circuit. Water pressure is less than 5 lt/min or less than 0.5 bar [50 kPa]. 4. Overflow not inserted properly (only for appliances without drain pump). 5. Tank filling valve faulty. 	<ol style="list-style-type: none"> 1. Open the inlet water tap. 2. Clean the water inlet filter. 3. Check the water pressure of the main water tap. It must be 0.5 bar [50 kPa] at least. 4. Insert properly the overflow. 5. Please call Service Center.
B1	Warning	Inefficient drainage	<ol style="list-style-type: none"> 1. Overflow not removed. 2. The waste outlet pipe and/or the overflow aperture obstructed. 3. Air-trap and/or tank pressure switch dirty. 4. Drain pipe kink, pinch or twist, resulting in a water flow restriction. 5. Wash tank return pipe, connected to the pump vent, is kinked or blocked. 6. Drain pipe broken (only for versions with drain pump). 7. Drain pump blocked. 8. Tank pressure switch faulty. 	<ol style="list-style-type: none"> 1. Remove the overflow. 2. Remove any obstruction from the waste outlet pipe and/or the overflow aperture. 3. Clean the air-trap. 4. Make sure drain pipe does not kink, pinch or twist. 5. Please call Service Center. 6. Please call Service Center. 7. Please call Service Center. 8. Please call Service Center.
B2	Warning	Tank water level too high	<ol style="list-style-type: none"> 1. The waste outlet pipe and/or the overflow aperture obstructed. 2. Air-trap and/or tank pressure switch dirty. 3. Tank pressure switch faulty. 4. Tank filling valve YV1 faulty or blocked. 5. Tank filling valve relay stuck (RL5 on AP2 electronic board). 	<ol style="list-style-type: none"> 1. Remove any obstruction from the waste outlet pipe and/or the overflow aperture. 2. Clean the air-trap. 3. Please call Service Center. 4. Please call Service Center. 5. Please call Service Center.

Anomaly	Type of anomaly	Description	Possible causes	Actions
C1	Warning	Boiler temperature rise too fast <u>Wash cycle longer than expected. Low washing performance. Rinse phase with cold water.</u>	<ol style="list-style-type: none"> 1. Missing water. 2. Boiler heating elements contactor stuck. 3. Heating element(s) power rating wrong. 	<ol style="list-style-type: none"> 1. Make sure the inlet water tap is opened. 2. Please call Service Center. 3. Please call Service Center.
C2	Warning	Boiler temperature too high <u>Wash cycle longer than expected. Rinse phase with cold water.</u>	<ol style="list-style-type: none"> 1. Wrong parameter set. 2. Boiler water level sensor faulty. 3. Boiler heating elements contactor stuck. 	Please call Service Center.
C3	Warning	Wash tank temperature too high <u>Low washing performance.</u>	<ol style="list-style-type: none"> 1. The inlet water is too hot. 2. Wrong parameter set. 3. Rinse temperature set too high. 4. Relay or PCB faulty. 	<ol style="list-style-type: none"> 1. Make sure the inlet water temperature is max. 60°C. 2. Please call Service Center. 3. Please call Service Center. 4. Please call Service Center.
C4	Warning	Tank temperature sensor broken or disconnected <u>Low washing performance.</u>	<ol style="list-style-type: none"> 1. Tank temperature sensor is unplugged. 2. Tank temperature sensor and/or sensor wire is broken. 	Please call Service Center.
C5	Warning	Tank temperature sensor broken or short-circuited <u>Low washing performance.</u>	<ol style="list-style-type: none"> 1. Tank temperature sensor is unplugged. 2. Tank temperature sensor and/or sensor wire is broken. 	Please call Service Center.
C6	Warning	Boiler temperature sensor broken or disconnected <u>Low washing and rinse performances.</u>	<ol style="list-style-type: none"> 1. Boiler temperature sensor is unplugged. 2. Boiler temperature sensor and/or sensor wire is broken. 	Please call Service Center.
C7	Warning	Boiler temperature sensor broken or disconnected <u>Low washing and rinse performances.</u>	<ol style="list-style-type: none"> 1. Boiler temperature sensor is unplugged. 2. Boiler temperature sensor and/or sensor wire is broken. 	Please call Service Center.
C9	Blocking Appliance stops	Automatic hood does not work <u>Switch OFF/ON the appliance. If the problem persists call the service centre.</u>	<ol style="list-style-type: none"> 1. One or more micro-switches of the door does not work correctly. 2. Automatic hood motor faulty. 3. Rack of hood blocked. 	Please call Service Center.
C10	Warning	Rinse temperature sensor broken or disconnected <u>Low washing and rinse performances.</u>	<ol style="list-style-type: none"> 1. Rinse temperature sensor is unplugged. 2. Rinse temperature sensor and/or sensor wire is broken. 	Please call Service Center.
C11	Warning	Rinse temperature sensor broken or short-circuited <u>Low washing and rinse performances.</u>	<ol style="list-style-type: none"> 1. Rinse temperature sensor is unplugged. 2. Rinse temperature sensor and/or sensor wire is broken. 	Please call Service Center.
C12	Blocking Appliance stops	Tank level sensor does not work	<ol style="list-style-type: none"> 1. Air-trap dirty or water in the hose that it connects the pressure switch SP1. 2. SP1 sensor connector CX8/ X9 is unplugged. 3. SP1 sensor is faulty or broken. 	<ol style="list-style-type: none"> 1. Clean the tank and remove any visible clogging from the air trap. Switch OFF/ON: if the problem persists call Service Centre. 2. Please call Service Center. 3. Please call Service Center.
C13	Warning	Rinse pump does not work <u>Low rinse performance.</u>	<ol style="list-style-type: none"> 1. Rinse pump malfunction. 2. Air trap hose is kinked or blocked. 	Please call Service Center.

Anomaly	Type of anomaly	Description	Possible causes	Actions
E1	Warning for manual model Blocking Appliance stops for automatic model	Communication error	1. Communication cable connector faulty. 2. Hardware faulty.	Please call Service Center.
E2	Warning	Tank temperature low <u>Low washing performance.</u>	1. Tank heating element faulty. 2. Heating element connection faulty. 3. Power rating wrong. 4. Relay RL4 on AP2 electronic board faulty. 5. Overheating thermostat trip or faulty.	Please call Service Center.
E2	Warning	Boiler temperature low <u>Low rinse performance.</u>	1. Heating element or elements faulty. 2. Heating element connection faulty. 3. Heating element contactor faulty. 4. Heating element contactor power supply missing.	Please call Service Center.
F21 – F22¹	Warning		Resin regeneration cycles are not performed. The appliance continues to operate without water softener.	Please call Service Center.

1. Only for appliances with incorporated continuous water softener.

CE