

HORIZONTAL COUNTERS
TAVOLI ORIZZONTALI

ECOSTORE HP & CL h700

Right side cooling unit

Type ref.	Ref	Page	Description	Brand
H7NTN2BHC	a	3 to 13	Counter 2 compartments refrigerated	all
H7NTN3BHC	b	3 to 13	Counter 3 compartments refrigerated	all
H7NTN4BHC	c	3 to 13	Counter 4 compartments refrigerated	all
H7NBT2BHC	d	3 to 14	Counter 2 compartments freezer	all
H7NBT3BHC	e	3 to 14	Counter 3 compartments freezer	all
H7NBT2B	f	3 to 14	Counter 2 compartments freezer	all
H7NBT3B	g	3 to 14	Counter 3 compartments freezer	all

Note:

Page 13 control panel HP premium

Page 14 control panel CL concept line

Index

Identification Type Ref./Identificazione type Ref.	2
Body module/corpo armadio	3
Spare part list/Lista ricambi	4
Door and drawers/ Porte e cassetti	5,6,7
Spare part list/Lista ricambi	8
Top/Ripiano	9
Spare part list/Lista ricambi	10
Cooling unit Refrig. & Freezer/Gruppo Refrigerato & Freezer Gas R290 &R404a	11
Spare part list/Lista ricambi	12
Control panel/Pannello di controllo HP premium	13
Control panel/Pannello di controllo CL concept line	14
Spare part list/Lista ricambi	15

Bold= last change/Grassetto =ultima modifica

Rev. 5

From Ser. Nr.... Up to Ser. Nr....	Ed. 2017-10 Updated 2023/07	Page: 1	Doc No:595R30300
---------------------------------------	--------------------------------	---------	-------------------------

How to put in relation the “Type Ref.” reported on the data plate with the “Type reference” reported on the front page of the Spare Part Catalogue:

The “Type Ref.” represents a group of models/brands all with similar technical features, hence possible to be reported under the same scheme in terms of exploded views.

Find below an identification example: **H7NTN2BHC**

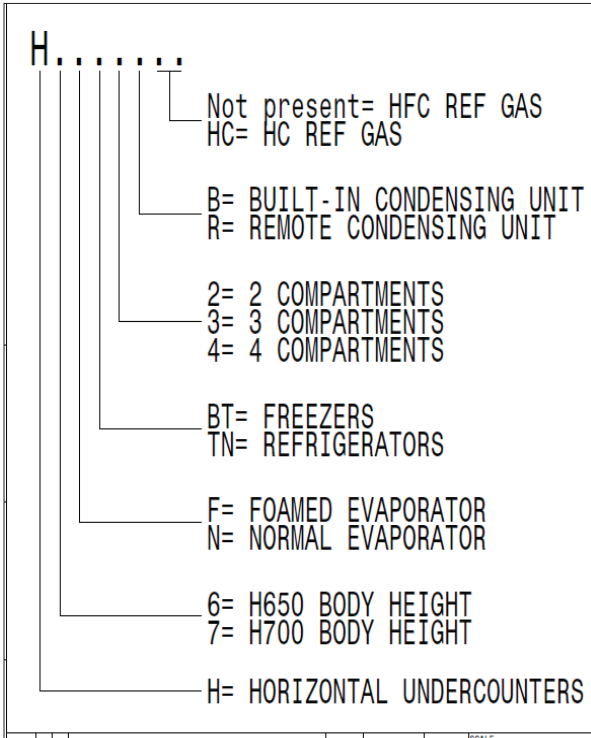

F. Mod. EH2H7AA	Comm. Mod. EH2H7AA	Type Ref. H7NTN2BHC	2017
PNC 9VTX 710000 00	Ser. No. 70810001	Cyclopentane	
W Tot. 0.25 kW	Volt 220-240 V	1 ~ 50 Hz	Total Current 1.9 A
Potenza Sbrinamento / Defrost Power	0.29 kW	Classe/Class 5	GWP 3 CO2-eq 0 t
Resistenza Evaporazione/Evaporation Heater El.	kW	Refrigerante / Refrigerant R290	0,07 kg.
Illuminazione / Lighting	W	Cap. 240	MADE IN ITALY
NF nominal Charge			
Rated Pressure	MPa		
IP21			
Electrolux Professional SpA - Viale Treviso, 15 - 33170 Pordenone (Italy)			

For the right spare code identification follow the steps:

1. type in the website the PNC reported on the data plate.
2. The website will automatically display this spare part catalogue.
3. The spare part code at this point is referenced through the “Type reference” as from the front page by the relevant “Ref”.

Come mettere in relazione il “Type Ref.” Riportato sulla targhetta caratteristica con il “Type reference” riportato sul frontespizio del catalogo ricambi:

Il “Type Ref.” Rappresenta un gruppo di modelli/marchi con simili caratteristiche tecniche, ossia possibili da rappresentare con il medesimo schema in termini di vista esplosa.

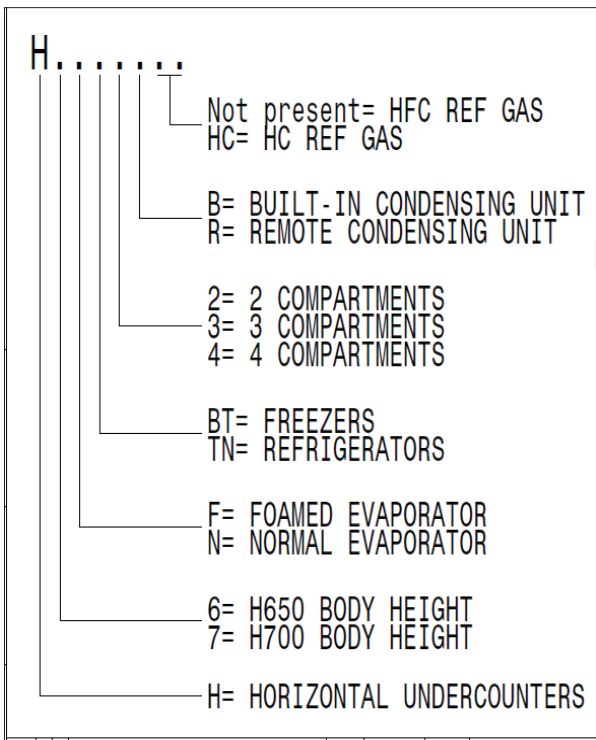

Qui di seguito un esempio di identificazione: **H7NTN2BHC**

F. Mod. EH2H7AA	Comm. Mod. EH2H7AA	Type Ref. H7NTN2BHC	2017
PNC 9VTX 710000 00	Ser. No. 70810001	Cyclopentane	
W Tot. 0.25 kW	Volt 220-240 V	1 ~ 50 Hz	Total Current 1.9 A
Potenza Sbrinamento / Defrost Power	0.29 kW	Classe/Class 5	GWP 3 CO2-eq 0 t
Resistenza Evaporazione/Evaporation Heater El.	kW	Refrigerante / Refrigerant R290	0,07 kg.
Illuminazione / Lighting	W	Cap. 240	MADE IN ITALY
NF nominal Charge			
Rated Pressure	MPa		
IP21			
Electrolux Professional SpA - Viale Treviso, 15 - 33170 Pordenone (Italy)			

Per identificare il corretto codice ricambio procedere con:

1. Digitare nel website il PNC riportato sulla targhetta caratteristica.
2. Il website mostrerà automaticamente questo catalogo ricambi.
3. A questo punto, il codice ricambio è identificabile attraverso il “Type reference” come indicato nel frontespizio sotto la relativa voce “Ref”.

MODEL=H7NTN2BHC
H7NBT2BHC

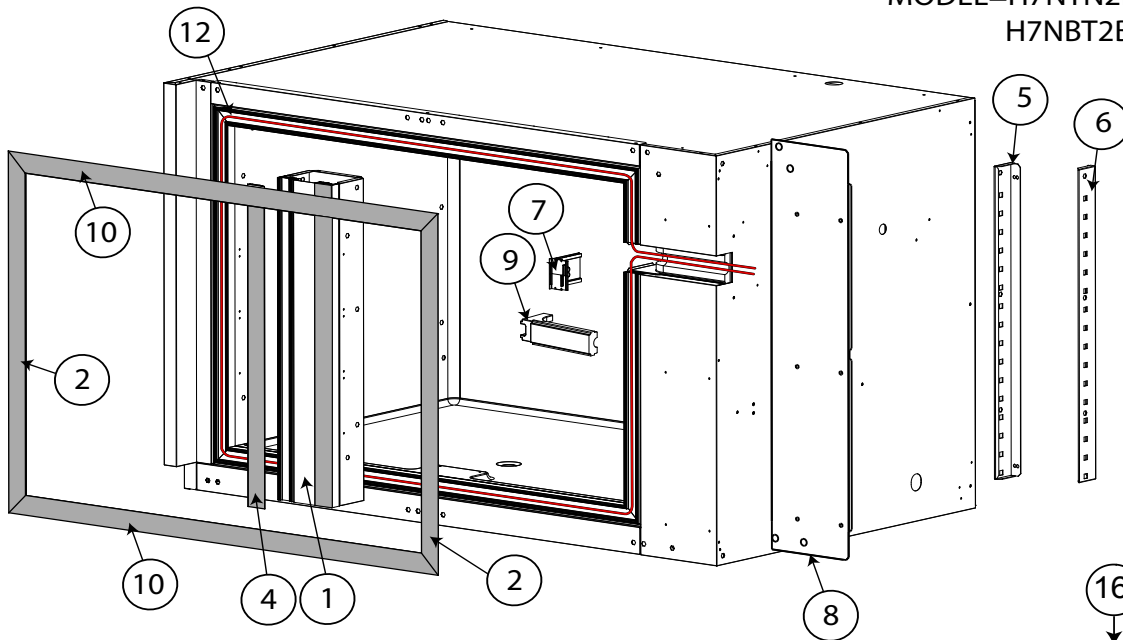

MODEL=H7NTN3BHC
H7NBT3BHC

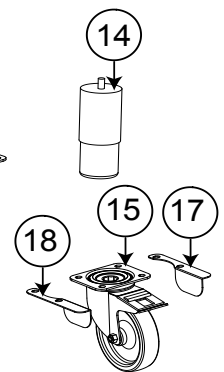
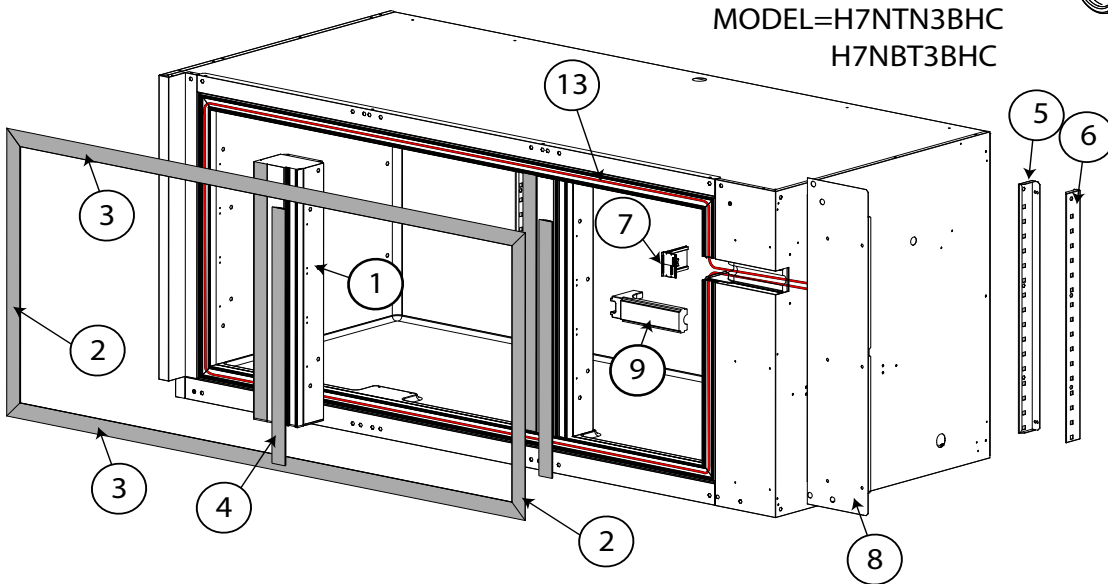

MODEL=H7NBT4BHC

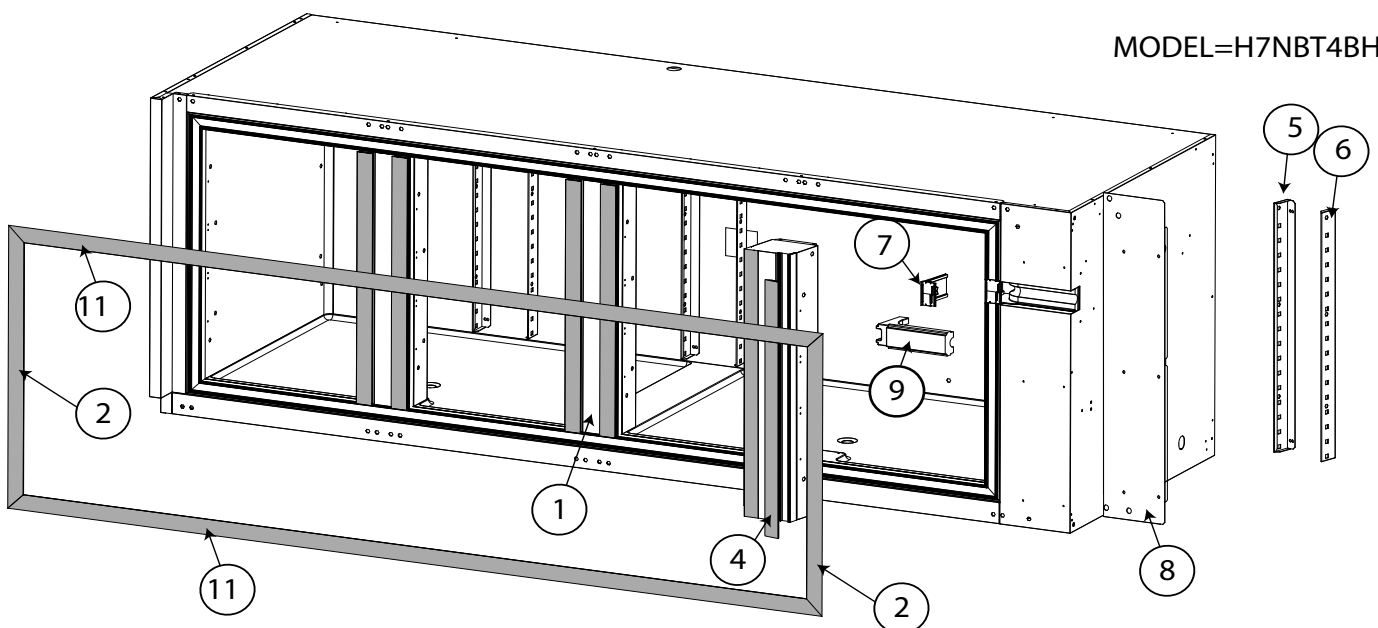

Pos	Code	Factory code	Description	Descrizione	Ref/notes
Pag. 3 Body Assembly			Corpo schiumato		
1	095337	835R54002	FOAMED VERTICAL PILLAR ASSEMBLED	MONTANTE ASSEMBLATO	a,b,c up to 9131
1	096522	835R67901	FOAMED VERTICAL PILLAR ASSEMBLED	MONTANTE ASSEMBLATO	a,b,c from 9141 d,e,f,g from 9391
1	095345	835R56401	FOAMED VERTICAL PILLAR ASSEMBLED	MONTANTE ASSEMBLATO	d,e,f,g up to 9131
1		835R68101	FOAMED VERTICAL PILLAR ASSEMBLED	MONTANTE ASSEMBLATO	d,e,f,g from 9141 up to 9381
2	095236	543R16400	VERTICAL FRAME COVER	COPERCHIO CORN.VERT. TAV 2/3/4V	a,b,c
2	095346	543R19801	VERTICAL FRAME COVER	COPERCHIO CORN.VERT. TAV 2V BT	d,e,f,g
3	095246	543R16600	HORIZONTAL FRAME COVER	COPERCHIO CORN ORIZZ TAV 3V TN	b
3	095253	543R19500	HORIZONTAL FRAME COVER	COPERCHIO CORN ORIZZ TAV 3V BT	e,g
4	095338	543R17701	VERTICAL FRAME COVER FOR PILLAR	MONTANTE VERTICALE COPERTURA	a,b,c
4	095347	543R19700	VERTICAL FRAME COVER FOR PILLAR	MONTANTE VERTICALE COPERTURA	d,e,f,g
5	095321	503R16702	REAR RIGHT SUPPORT GRIDS H700	SUPPORTO POSTERIORE DX	
6	095322	502R84504	REAR LEFT SUPPORT GRIDS H700	SUPPORTO POSTERIORE SX	
7	095323	543R17804	HEAT EXCHANGER HOUSING SIDE	COPERTURA TUBI SCAMBIATORE	
8	095224	503R24900	FRONT COVER PANEL SIDE (RIGHT) A304	PANNELLO FRONTALE DX A304	
9	095225	569R09502	INSULATION BLOCK HEAT EXCH.	ISOLAMENTO PER TUBI SCAMBIATO.	
10	095226	543R16500	HORIZONTAL FRAME COVER	COPERCHIO CORN ORIZZ TAV 2V	a
10	095254	543R19400	HORIZONTAL FRAME COVER	COPERCHIO CORN ORIZZ TAV 2V	d
11	095255	543R16700	HORIZONTAL FRAME COVER	COPERCHIO CORN ORIZZ TAV 4V	c
12	099330	617R06701	FRAME HEATING CABLE 2V L 5450 mm	CAVO RISCALDANTE CORNICI 2V porte	d,f only door
12	095256	617R15600	FRAME HEATING CABLE 2V L 6700 mm	CAVO RISCALDANTE CORNICI 2V	d,f 1 door_2 1/2 draw.
12	095257	617R15900	FRAME HEATING CABLE 2V L 9140 mm	CAVO RISCALDANTE CORNICI 2V	d,f 6 1/3 draw.
12	095258	617R15700	FRAME HEATING CABLE 2V L 8320 mm	CAVO RISCALDANTE CORNICI 2V	d,f 2 1/2 draw._3 1/3 draw.
12	095259	617R15800	FRAME HEATING CABLE 2V L 7490 mm	CAVO RISCALDANTE CORNICI 2V	d,f 4 1/2 draw. 1 door_3 1/3 draw.
13	094096	617R09500	FRAME HEATING CABLE 3V L 8140 mm	CAVO RISCALDANTE CORNICI 3V	e,g only door
13	095260	617R16000	FRAME HEATING CABLE 3V L 8600 mm	CAVO RISCALDANTE CORNICI 3V	e,g 2 door_2 1/2 draw.
13	095261	617R16100	FRAME HEATING CABLE 3V L 9400 mm	CAVO RISCALDANTE CORNICI 3V	e,g 1 door_4 1/2 draw. 2 door_3 1/3 draw.
13	095262	617R16200	FRAME HEATING CABLE 3V L 10200 mm	CAVO RISCALDANTE CORNICI 3V	e,g 6 1/2 draw. 1 door_2 1/2 draw._3 1/3 draw.
13	095263	617R16300	FRAME HEATING CABLE 3V L 12700 mm	CAVO RISCALDANTE CORNICI 3V	e,g 9 1/3 draw.
13	095264	617R16400	FRAME HEATING CABLE 3V L 11030 mm	CAVO RISCALDANTE CORNICI 3V	e,g 1 door_6 1/3 draw. 4 1/2 draw._3 1/3 drawers
13	095265	617R16500	FRAME HEATING CABLE 3V L 11850 mm	CAVO RISCALDANTE CORNICI 3V	e,g 2 1/2 draw._6 1/3 drawers
14	096610	0518R01100	FOOT H 150 WHIT CENTRAL SCREW	PIEDE NYLON VITE CENTRALE+ RIVEST. INOX H150	
15	087110	0835739900	WHEEL WITH BRAKE H155	RUOTA A PIASTRA ROT. CON FRENO	H = 155
15	095544	518R08700	WHEEL WITH BRAKE H100	RUOTA A PIASTRA ROT. CON FRENO	H = 100
16	087111	0835740000	WHEEL WITH-OUT BRAKE H155	RUOTA A PIASTRA ROT. NO FRENO	H = 155
16	095545	518R08800	WHEEL WITH-OUT BRAKE H100	RUOTA A PIASTRA ROT. NO FRENO	H = 100
17	095324	0503R38502	RIGHT WHEEL LEVER BRAKE	FERMO RUOTA DESTRO	
18	095325	0503R38602	LEFT WHEEL LEVER BRAKE	FERMO RUOTA SINISTRO	

881R40103
881R57901
881R75100
881R75000

APX/ZAN H700 DOOR

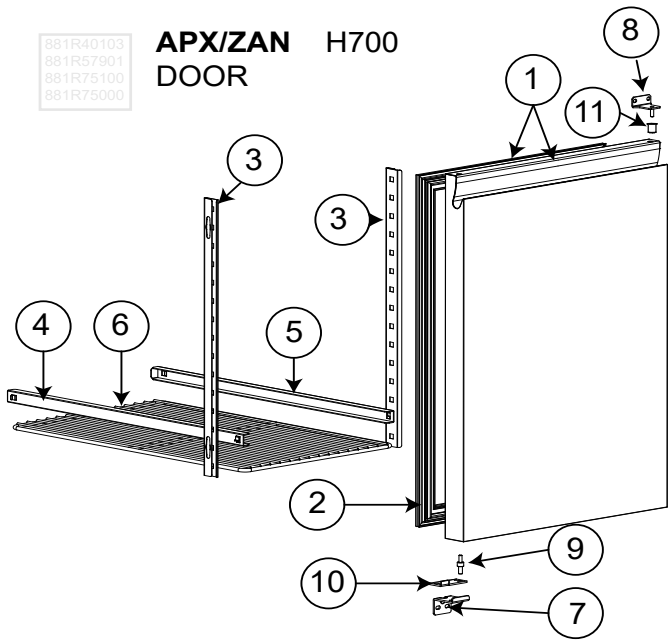

881R53002
881R74500
881R57800
881R74400

ELUX H700 DOOR

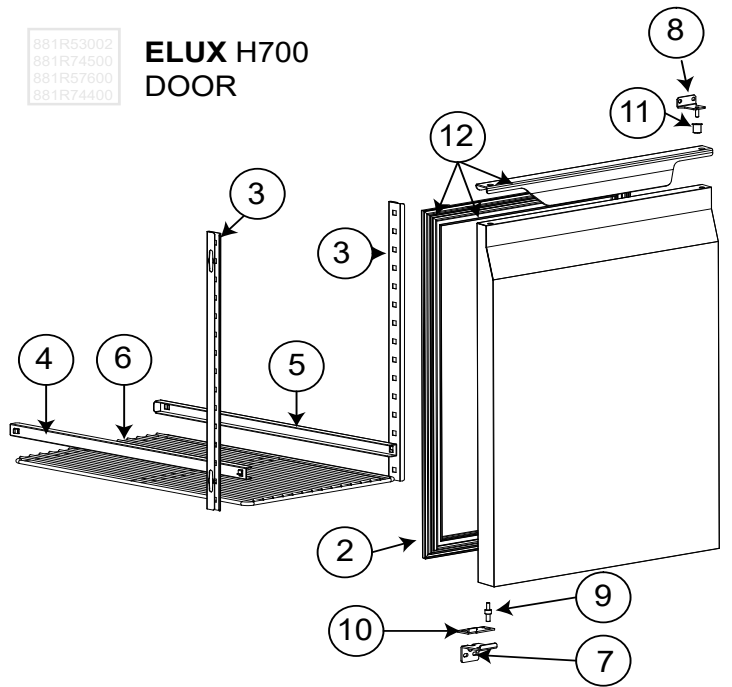

1/3 HOLLOW DRAWERS APX/ZAN H700 DRAW 1/3

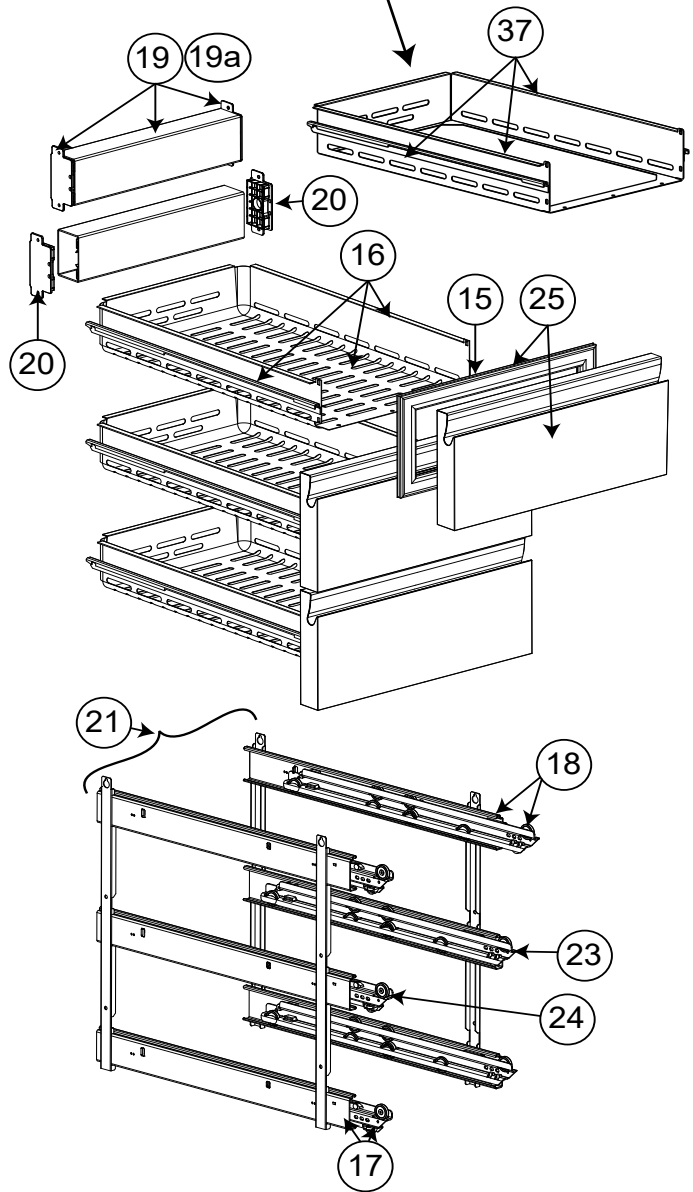

881R57001
881R77000

ELUX H700 DRAW. 1/3

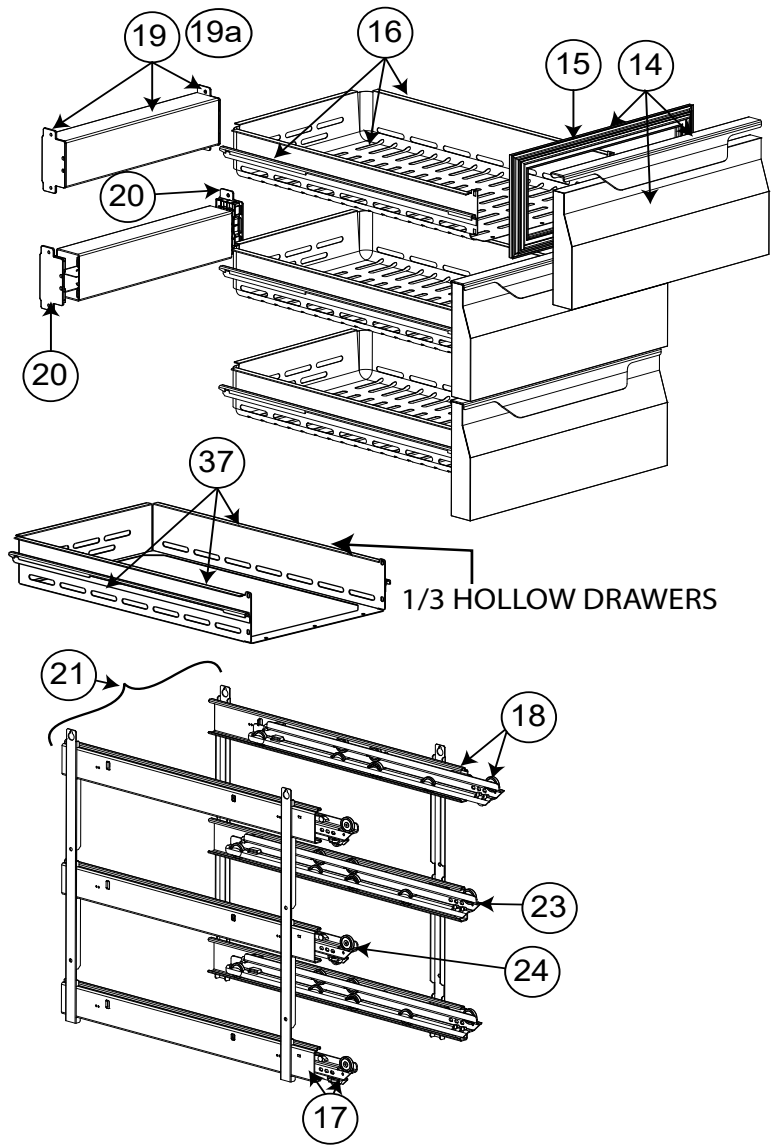

ELUX H700
DRAW. 1/2

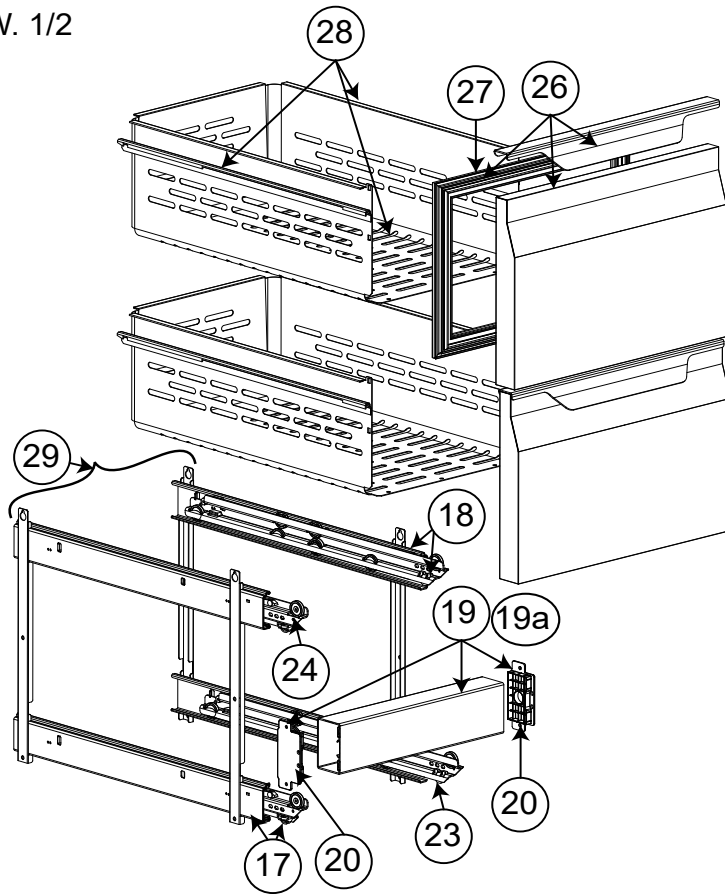

1/2 HOLLOW DRAWERS

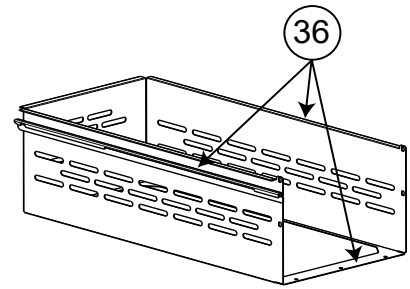

APX/ZAN H700
DRAW.1/2

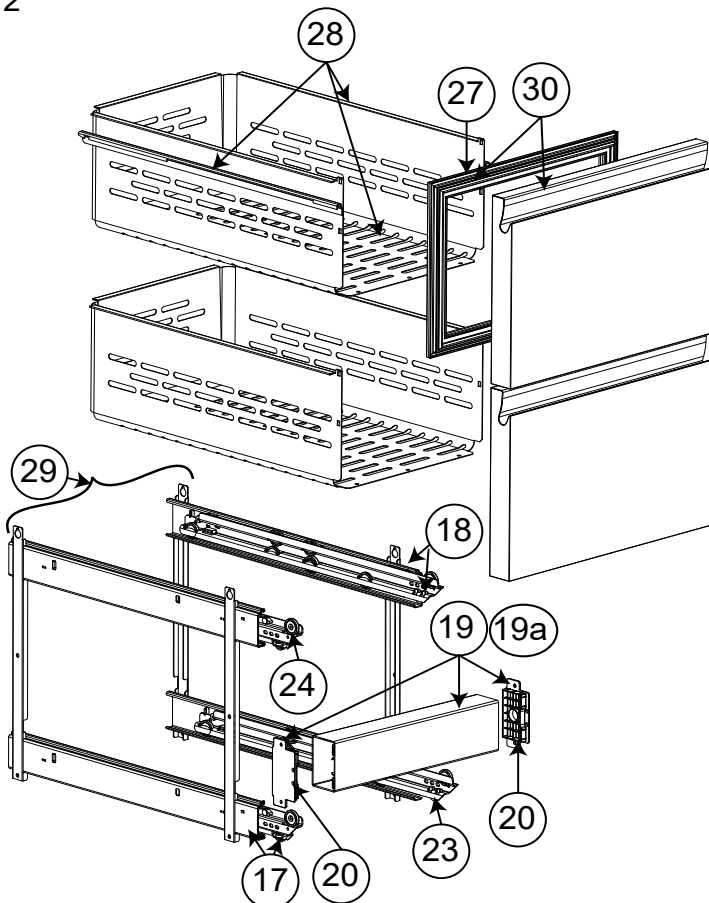

1/2 HOLLOW DRAWERS

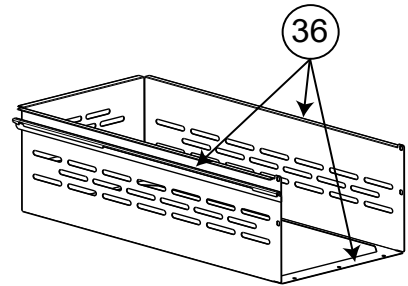

881R57601
881R77600

ELUX H700
BOTTLE DRAW.

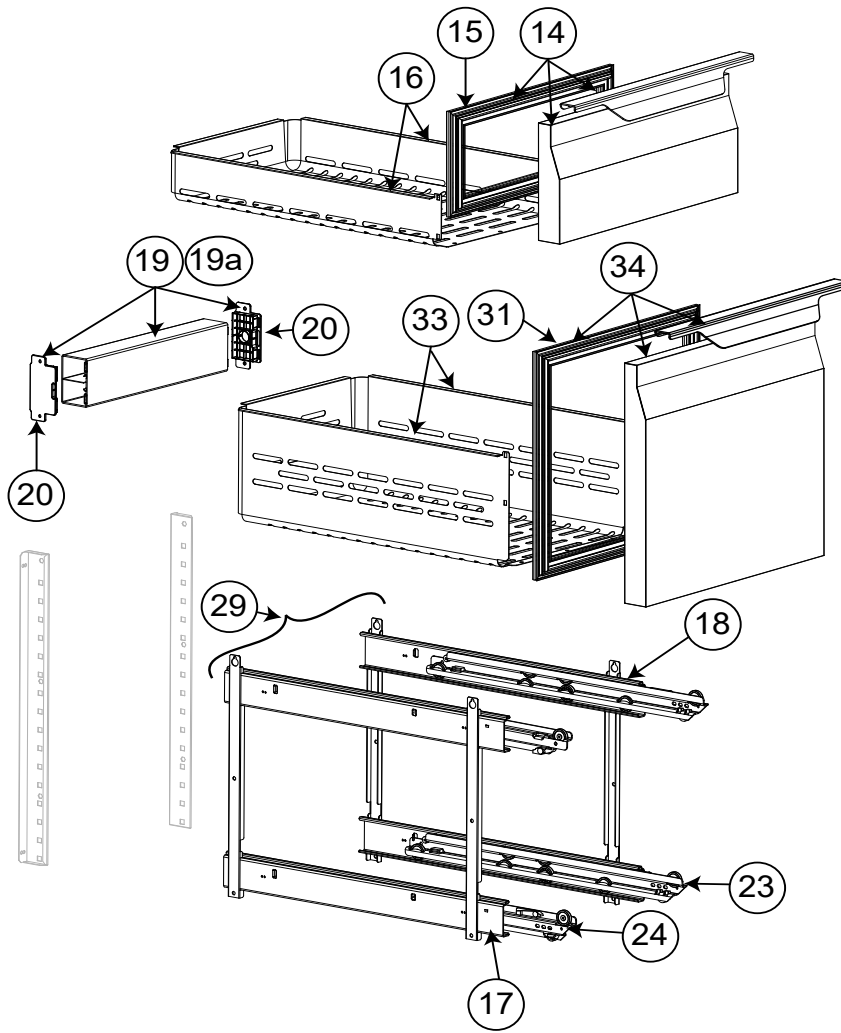

881R70800

APX/ZAN H700
BOTTLE DRAW.

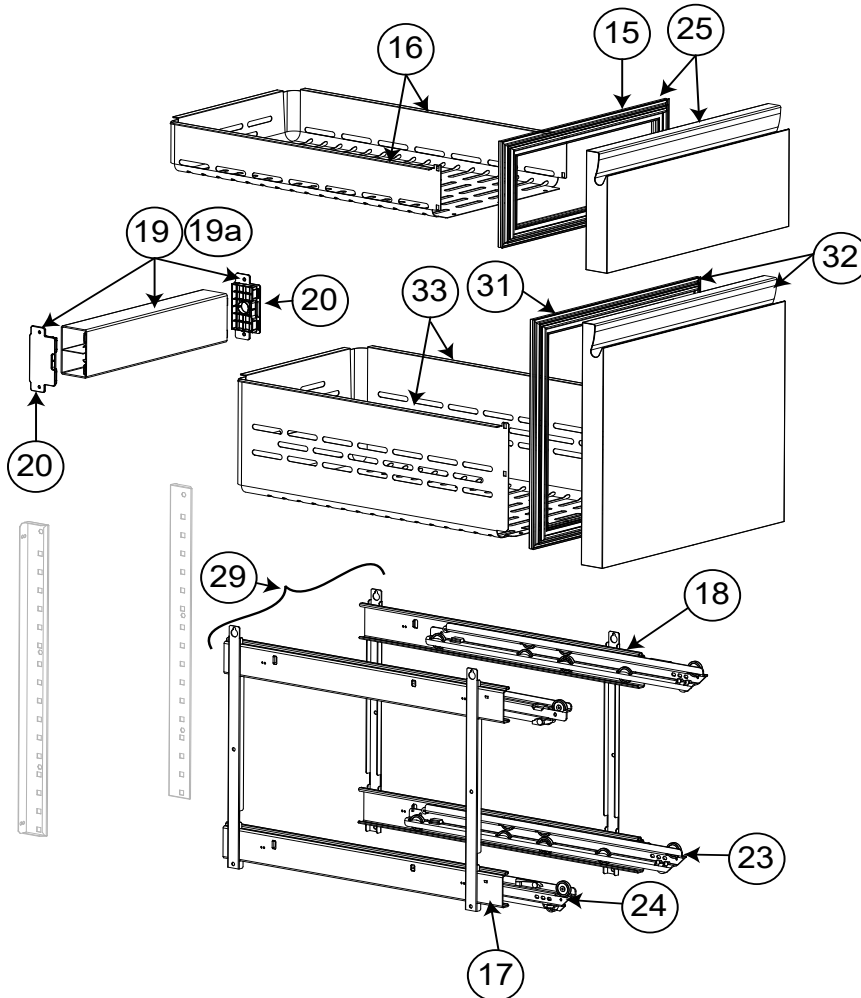

881R70700

Pos	Code	Factory code	Description	Descrizione	Ref/notes
Pag. 5_6_7 Doors and Drawers				Porta e Cassetti	
1	095802	835R52104	FOAMED D. ASSEMBLY H700 apx/zan	PORTA SCHIUMATA CON GUARNI	brand Apx_Zan
2	095238	548R11101	A886 MAGNETIC GASKET H700	GUARNIZIONE PORTA	
3	095227	503R09702	FRONT SUPPORT GRIDS H700	FRONTALE SUPPORTO GUIDE	
4	095228	502R84601	LEFT GUIDE FOR SHELF	GUIDA A "C" SX TAV NGC H700/H650	
5	095229	502R84701	RIGHT GUIDE FOR SHELF	GUIDA A "C" DX TAV NGC H700/H650	
6	095231	514R23500	SHELF	GRIGLIA RILSAN TAVOLO H650/H700	
7	095326	505R23702	LOWER HINGE H650/H700	CERNIERA INFERIORE	
8	095327	505R23803	UPPER HINGE H650/H700	CERNIERA SUPERIORE	
9	087667	514746701	PIN FOR DOOR	PERNO PER CERNIERA INFERIORE	
10	089146	800735200	DOOR OPENING END COURSE	PIASTRINA FERMO BATTUTA PORTA	
11	081807	549700000	DOOR BUSH	BOCCOLA X CERNIERA	
12	095511	835R51907	FOAMED DOOR ASSEMBLY H700 elux	PORTA CON GUARNIZIONE ELECTROLUX	brand: Elux
14	095512	835R53506	FOAMED DRAWERS 1/3 ELUX	ASS.CASS.1/3 SCHIUMATO TAVOLO ELEC	brand: Elux (+GASKET)
15	095240	548R11801	GASKET DRAWER 1/3	GUARNIZ.CASS.1/3 TAV NGC H700	
16	095551	833R36003	1/3 DRAW+GUIDES (WITHOUT FRONTAL)	ASS.INVOLUCRO CASSETTO+GUIDE	Up to 2025/03
16	09A207	833R52900	1/3 DRAW+GUIDES (WITHOUT FRONTAL)	ASS.INVOLUCRO CASSETTO+GUIDE	From 2025/04
17	09A1PF	503R07000	LEFT SLIDING GUIDE	GUIDA SCORREVOLE SX	Up to 2025/03
17	09A21P	0503R03P00	LEFT SLIDING GUIDE	GUIDA SCORREVOLE SX	From 2025/04
18	09A1PG	503R07100	RIGHT SLIDING GUIDE	GUIDA SCORREVOLE DX	Up to 2025/03
18	09A21Q	0503R03R00	RIGHT SLIDING GUIDE	GUIDA SCORREVOLE DX	From 2025/04
19	095365	875R33501	CROSSBEAM ASSEMBLY - DRAWERS	TRAVERSA CASSETTO 1/ E 1/2 TN	only refrigerated Up to 2019/13
19	096130	835R70800	CROSSBEAM ASSEMBLY - DRAWERS	TRAVERSA CASSETTO TN	only refrigerated From 2019/14
19a	095366	835R53801	FOAM PILLAR ASS. - DRAWERS	TRAVERSA CASSETTO 1/3 E 1/2 BT	only freezer
20	095552	543R18901	PLASTIC PILLAR PLUG RIGHT/LEFT	TAPPO TRAVERSA DX E SX	only refrigerated
21	095553	833R37202	1/3 SUPPORT +GUIDE ASSEMBLY	SUPPORTO TELAIO DX E SX CASS.1/3	Up to 2025/03
21	09A208	833R52500	1/3 SUPPORT +GUIDE ASSEMBLY	SUPPORTO TELAIO DX E SX CASS.1/3	From 2025/04
23	095267	832R23300	RIGHT SUPPORT DRAWERS 1/3	CARRELLO DX PER MOD.CASSETTI	Up to 2025/03
23	09A204	855R0BX00	RIGHT SUPPORT DRAWERS 1/3	CARRELLO DX PER MOD.CASSETTI	From 2025/04
24	095266	832R23200	LEFT SUPPORT DRAWERS 1/3	CARRELLO SX PER MOD.CASSETTI	Up to 2025/03
24	09A203	855R0BW00	LEFT SUPPORT DRAWERS 1/3	CARRELLO SX PER MOD.CASSETTI	From 2025/04
25	095554	835R54205	FOAMED FRONT DRAW. 1/3 APX/ZAN	ASS.CASS.1/3 SCHIUMATO TAVOLO	brand Apx_Zan (+GASKET)
26	095822	835R54106	FOAMED FRONT DRAW. 1/2 ELUX	ASS.CASS.1/2 SCHIUMATO TAVOLO ELEC	brand: Elux (+GASKET)
27	095239	548R11701	GASKET DRAWER 1/2	GUARNIZ.CASS.1/2 TAV NGC H700	
28	095814	833R35904	1/2 DRAW+GUIDES (WITHOUT FRONTAL)	INVOLUCRO CON GUIDE	Up to 2025/03
28	09A205	833R52800	1/2 DRAW+GUIDES (WITHOUT FRONTAL)	INVOLUCRO CON GUIDE	From 2025/04
29	095555	833R37302	1/2-2/3 SUPPORT +GUIDE ASSEMBLY	SUPP. TELAIO DX E SX CASS.1/2-2/3	Up to 2025/03
29	09A206	833R52400	1/2-2/3 SUPPORT +GUIDE ASSEMBLY	SUPP. TELAIO DX E SX CASS.1/2-2/3	From 2025/04
30	095556	835R54305	FOAMED FRONT DRAW. 1/2 APX_ZAN	ASS.CASS.1/2 SCHIUM. TAVOLO ZAN_APX	brand Apx_Zan (+GASKET)
31	095249	548R12500	GASKET DRAWER 2/3	GUARNIZ.CASS.2/3 TAV NGC H700	
32	095557	835R57703	2/3 FOAM. FRONT DRAW. ASS. ALPEN	ASS.CASS.2/3 SCHIUM. TAVOLO ZAN_APX	brand Apx_Zan (+GASKET)
33	095558	833R38500	2/3 DRAW+GUIDES (WITHOUT FRONTAL)	ASS.INVOLUCRO CASSETTO+GUIDE 2/3	Up to 2025/03
33	09A209	833R53000	2/3 DRAW+GUIDES (WITHOUT FRONTAL)	ASS.INVOLUCRO CASSETTO+GUIDE 2/3	From 2025/04
34	095559	835R57505	2/3 FOAM.FRONT DRAW. ASS. ELUX	ASS.CASS.2/3 SCHIUM. TAVOLO ELUX	brand: Elux (+GASKET)
*	095300		INCLUDE N°23 AND N°24 (1RIGHT +1 LEFT)	INCLUDE N°23 E 24,(1+1 GUIDA DX-SX)	
36	09A201	833R39800	1/2 STOR. HOLLOW DRAW. GUIDES	ASS. INVOLUCRO CASS.+GUIDE	Up to 2025/03
36	09A21A	833R53300	1/2 STOR. HOLLOW DRAW. GUIDES	ASS. INVOLUCRO CASS.+GUIDE	From 2025/04
37	09A202	833R40100	1/3 STOR. HOLLOW DRAW. GUIDES	ASS. INVOLUCRO CASS.+GUIDE	Up to 2025/03
37	09A21B	833R53400	1/3 STOR. HOLLOW DRAW. GUIDES	ASS. INVOLUCRO CASS.+GUIDE	From 2025/04

* = On demand

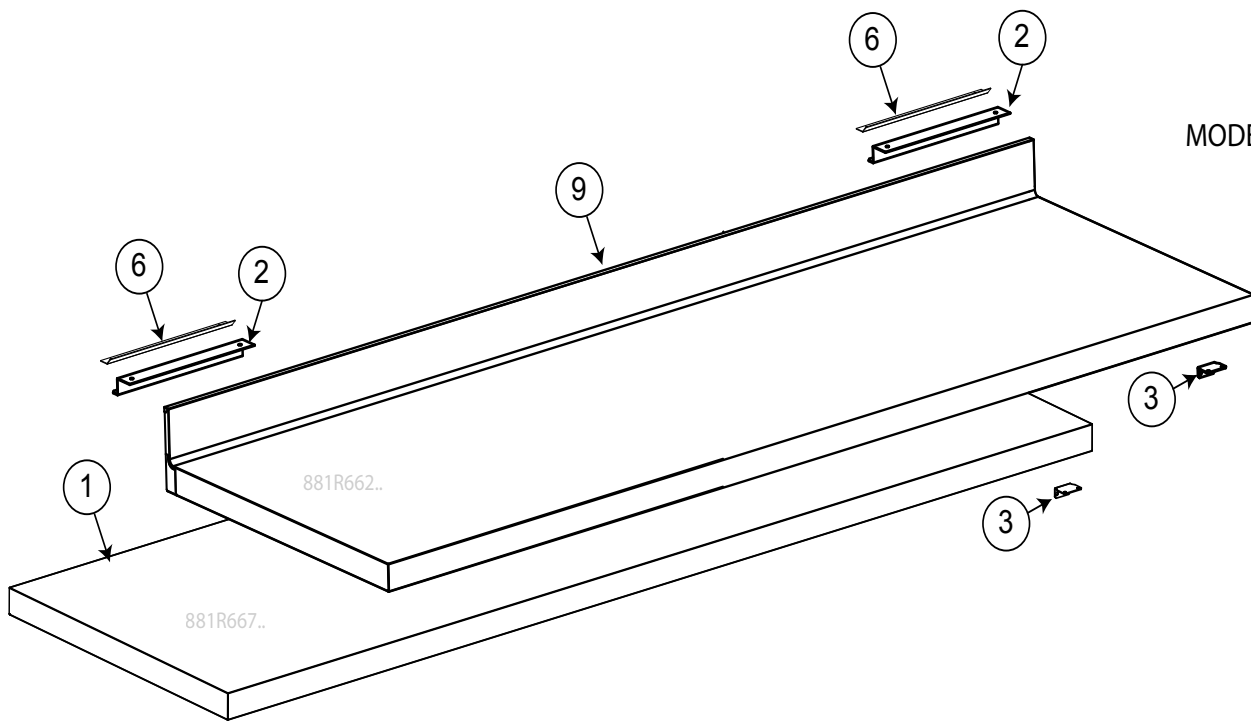

MODEL=H7NTN4BHC

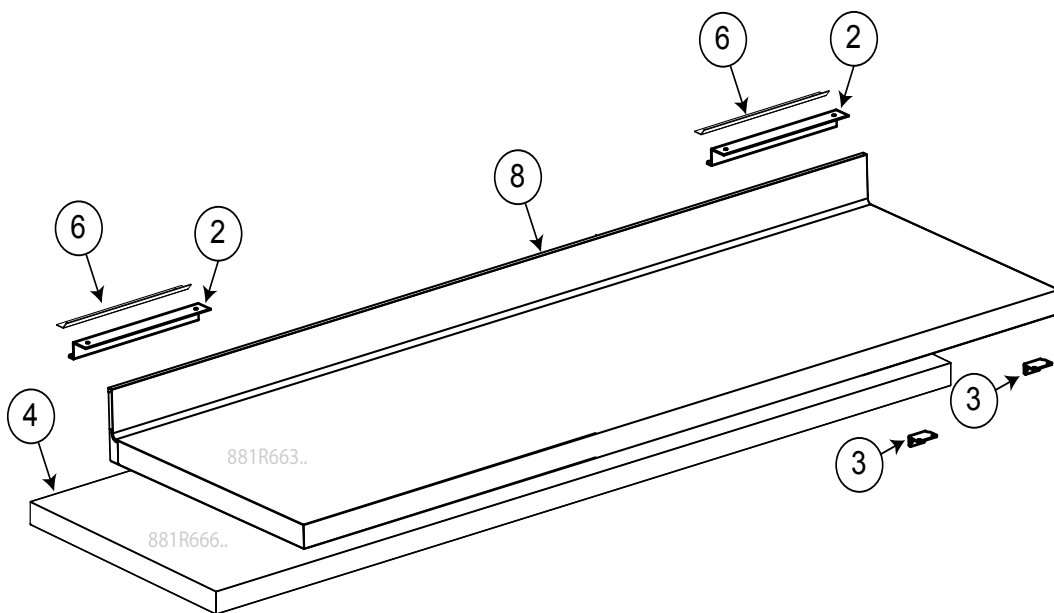

MODEL= H7NTN3BHC
H7NBT3BHC
H7NBT3B

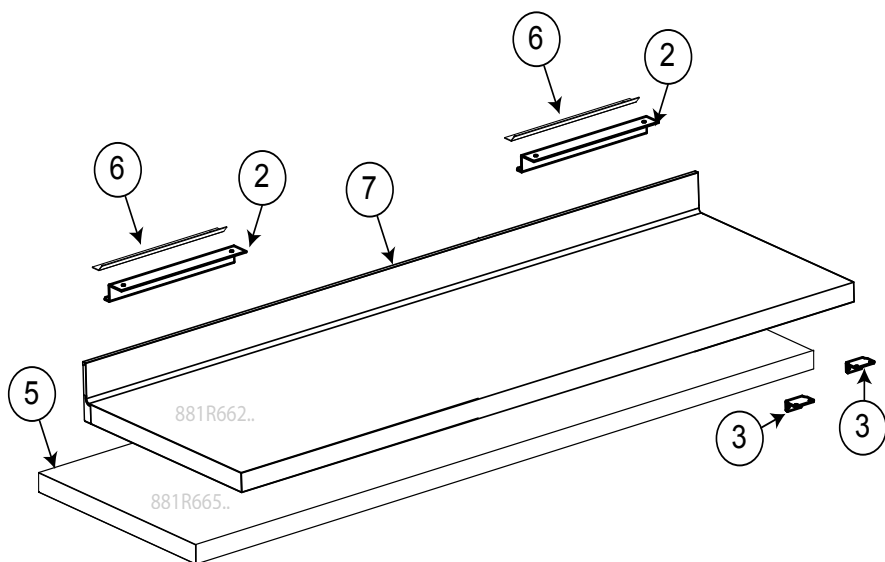

MODEL= H7NTN2BHC
H7NBT2BHC
H7NBT2B

Pos	Code	Factory code	Description	Descrizione	Ref/notes
			Worktop	Piano di lavoro	
1		881R66701	WORKTOP MODULE 4C H50	TOP 4 VANI H 50 DX	c (without S.back)
1		881R41504	WORKTOP MOD 4C HP PREM BI H50 NO/UPST L-R	TOP 4 VANI H 50 DX-SX	c (without S.back)
2		501775700	HOOK FOR TOP	GANCIO PER RIPIANO	
3	095330	505R25301	BRACKET SHELF	STAFFA PER RIPIANO	
4		881R66601	WORKTOP MODULE 3C H50	TOP 3 VANI H 50 DX	b,e (without S.back)
4	095562	881R58003	WORKTOP MODULE 3C HP NO/UPST L-R	TOP 3 VANI H 50 DX-SX	b,e (without S.back)
5		881R66501	WORKTOP MODULE 2C H50	TOP 2 VANI H 50 DX	a,d (without S.back)
5	095564	881R52904	WORKTOP MOD 2C NORMAL EVAP BI H50 NO/UPST L-R	TOP 2 VANI H 50 DX-SX	a,d (without S.back)
6	093186	505751500	HOOK FOR TOP ON THE COUNTER	FISSAGGIO RIPIANO AL TAVOLO	
7	096032	881R66201	WORKTOP ASS. WITH 2C	TOP CON ALZATINA 2 VANI DX	a,d (whit S.back)
7		881R65902	WORKTOP MOD 2C NORMAL EVAP BI H50 W/UPST L-R	TOP CON ALZATINA 2 VANI DX-SX	a,d (whit S.back)
8		881R66301	WORKTOP ASSEMBLY 3C	TOP CON ALZATINA 3 VANI DX	b,e (whit S.back)
8		881R66002	WORKTOP MODULE 3C HP BI 3C W/UPST L-R	TOP CON ALZATINA 3 VANI DX-SX	b,e (whit S.back)
9		881R66401	WORKTOP ASS. WITH 4C	TOP CON ALZATINA 4 VANI DX	c (whit S.back)
9		881R66102	WORKTOP MOD 4C HP PREM BI H50 W/UPST L-R	TOP CON ALZATINA 4 VANI DX-SX	c (whit S.back)
10					
11					
12					
13					
14					
15					
16					
17					
18					
19					
20					
21					
22					
23					
24					

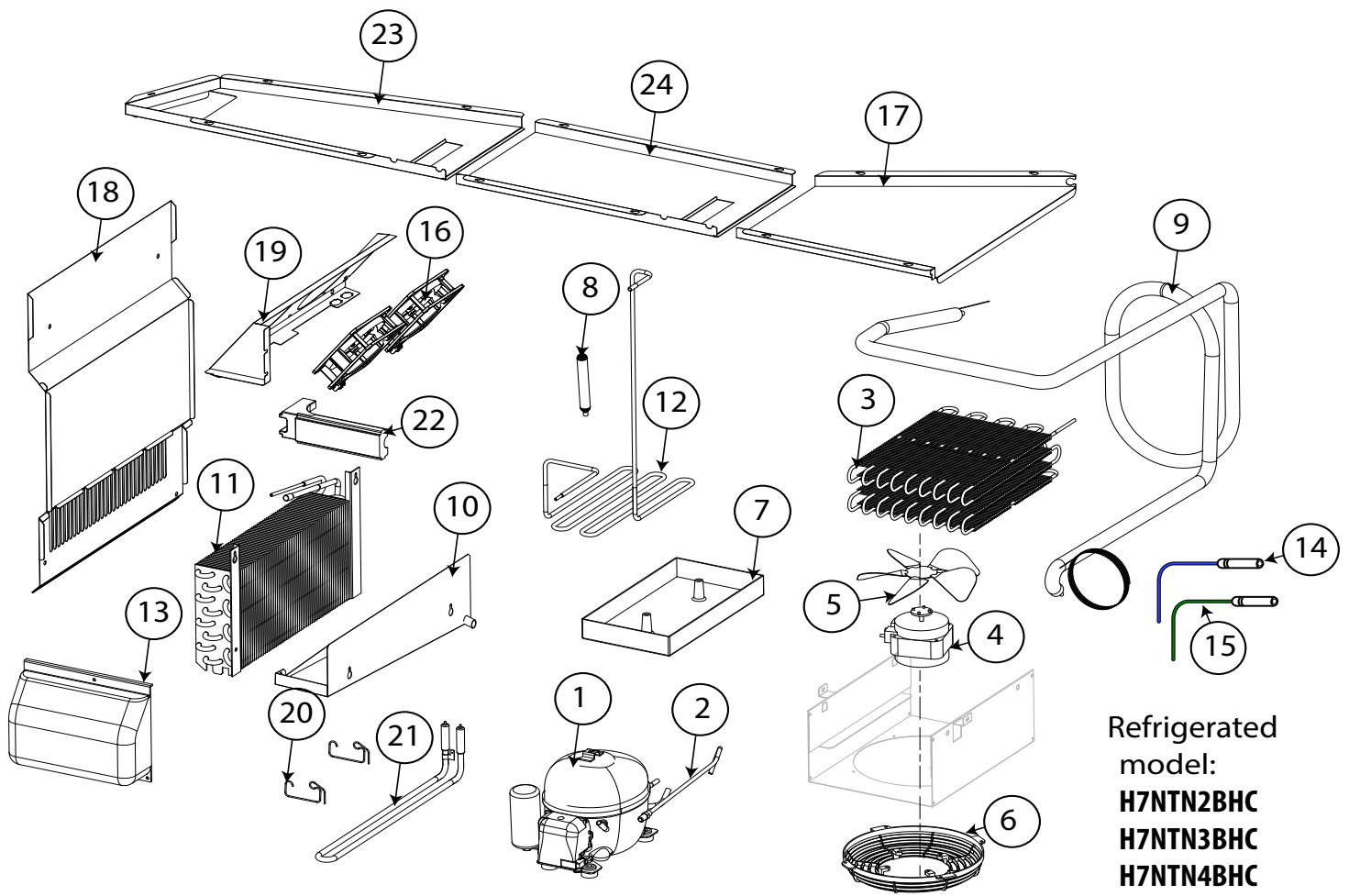

Refrigerated
model:
H7NTN2BHC
H7NTN3BHC
H7NTN4BHC

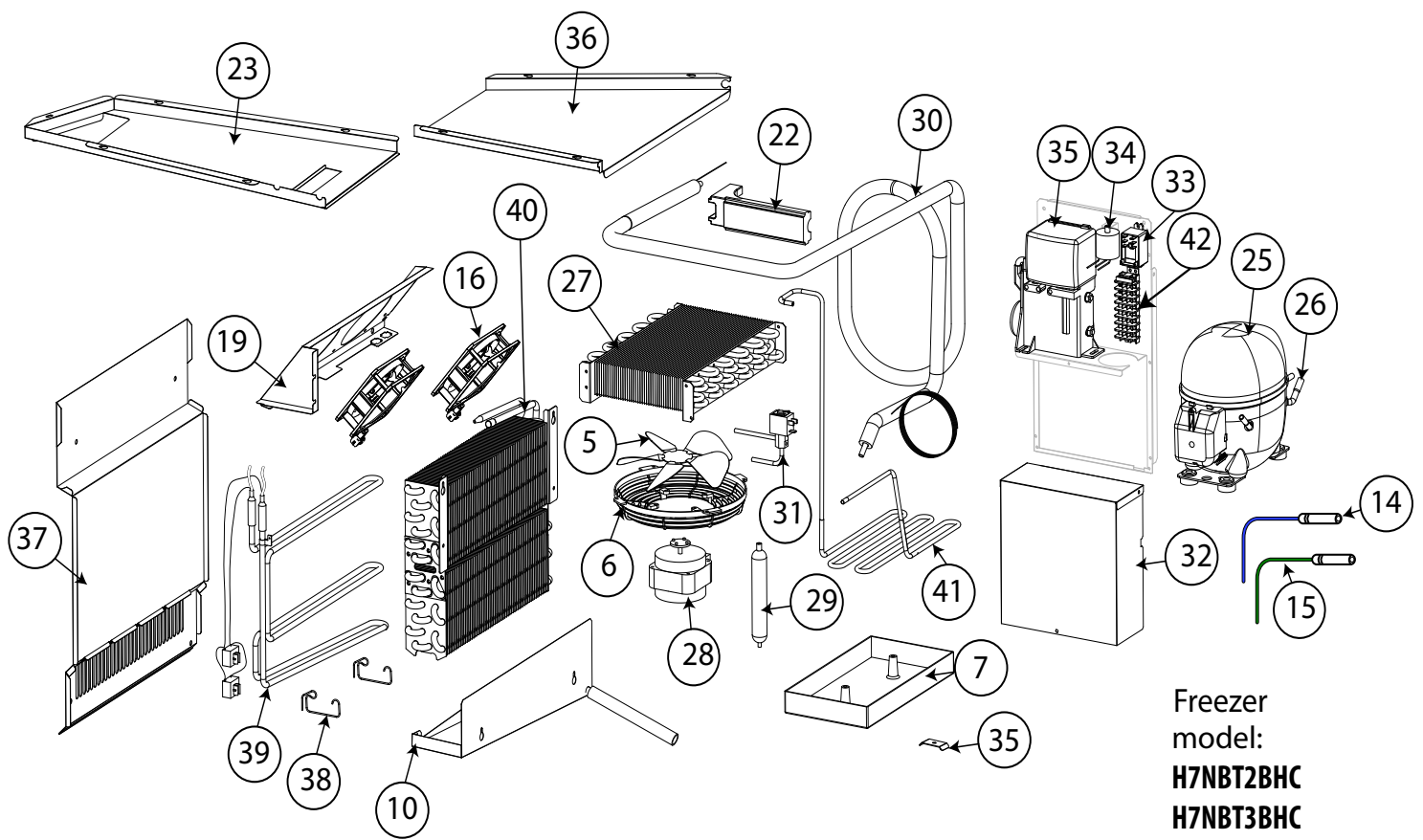

Freezer
model:
H7NBT2BHC
H7NBT3BHC
H7NBT2B
H7NBT3B

Pos	Code	Factory code	Description	Descrizione	Ref/notes
Cooling unit 2-3-4 comp. R290			Gruppo di raffreddamento 2-3-4 vani R290		
1	093425	684R05700	COMPRESSOR	COMPRESS. EMT6144U220-50 290	a,b,c
2	093223	515R14600	PIPE CHARGE GAS COMPRESSOR	TUBO VALVOLA DI CARICA	a,b,c
3	095271	830R11103	WIRING CONDENSER	CONDENSATORE FILI 2/3VANI NGC	a,b,c
4	094184	682R07700	CONDENSER FAN MOTOR	VENTILATORE 220-240V 50/60HZ10W	a,b,c
5	082874	511701900	CONDENSER FAN	VENTOLA ASP.A200-34 4012201	
6	089770	546709600	CONDENSER FAN PROTECTION	GRIGLIA SUPP.MOTOVENT.DIAM.200	
7	084585	549727300	CONDENSATION BASIN	BACINELLA RACC.CONDENSEA	
8	099949	858R00100	FILTER GR.	FILTRO GR.15 2 VIE FORI DIAM.2,5-5,0	a,b,c
9	095349	858R15901	BENT EXCHANGER ASSEMBLY R290	SCAMBIATORE	a,b,c
10	095350	503R25901	WATER COLLECTOR BASIN "RIGHT"	BACINELLA	
11	095273	830R12700	EVAPORATOR 8RH 25X22 H700 RIGHT	EVAPORATORE	a,b,c
12	095274	515R32201	SERPENTINE PIPE	TUBO DA COND A COMPR TAV 2-3-4V	a,b,c
13	095275	546R36901	PLASTIC ELECTRIC BOX	COPERTURA IN PLASTICA	a,b,c
14	092175	646R06900	BLUE PROBE CELL	SONDA 6X20 BLU 'CELL' L=3000	a,b,c
15	096125	646R07701	GREEN PROBE EVAPORATOR	SONDA 6X40 VERDE 'DEF' L=3000	a,b,c
16	095315	682R10700	AXIAL AC FAN 120X120X38 MM IP55	VENTILATORE CELLA	
17	095277	503R25500	AIR CONVEYOR H700 RIGHT A304	CONVOGLIATORE	a,b,c
18	095278	503R25800	EVAPORATOR COVER H700 "RIGHT"	PROTEZIONE EVAPORATORE	a,b,c
19	095351	503R25701	FAN SUPPORT EVAPORATOR	SUPPORTO VENTILATORI	
20	095279	514R24201	SPRING FOR HEATING ELEMENT.	MOLLA FIX. RESISTENZA TAV NGC TN	a,b,c
21	095316	617R17500	ARMOURED HEATER COUNTER FZ	RESISTENZA	a,b,c
22	095225	569R09502	INSULATING BLOCK	ISOLAMENTO TUBI SCAMBIATORE	
23		503R25600	END PART AIR CONVEYOR "R" A304	PARTE FINALE PER CONV. ARIA	b,c,e,g(with drawers)
24		503R24700	MID PART AIR CONVEYOR	PARTE CENTRALE PER CONV. ARIA	c
25	094840	684R11900	COMPRESSOR NEU2168U R290	COMPRESSORE NEU2168U	d,e with gas R290
25	095613	684R12900	COMPRESSOR NEU2178UGK R404a	COMPRESSORE NEU2178UGK	f,g with gas R404a
25	095645	684R13600	COMPRESSOR NEU2155GK 60HZ	COMPRESSORE NEU2155GK 60HZ	f,g 60HZ with gas R404a
26	0A8171	A02021800	RECHARGEABLE VALVE	VALVOLA DI RICARICA	d,e,f,g
27	095352	830R12601	CONDENSER BT NGC COUNTER	CONDENSATORE BT NGC	d,e,f,g
28	096661	682R12800	CONDENSER FAN MOTOR	VENTILATORE EBM IQ3612 -1800 RPM	d,e with gas R290 (see TB VTX2021_05)
28	095612	682R10800	CONDENSER FAN MOTOR	VENTILATORE EBM IQ3212 -1800 RPM	f,g with gas R404a (see TB VTX2021_05)
29	084078	805729802	FILTER GR.40	FILTRO GR.40 DISIDRATATORE	d,e,f,g
30	095353	858R16001	BENT EXCHANGER ASSEMBLY R290	SCAMBIATORE	d,e,f,g
31	094435	646R10502	SOLENOID VALVE	ELETTROVALVOLA 6W 220/230V	d,e,f,g
32	095354	503R29102	ELECTRIC BOX COVER	COPERTURA IMP.ELETTRICO	d,e,f,g
33	095281	648R08400	RELAY FINDER 66.82.8.230.0003	RELÈ FINDER 66.82.8.230.0003	d,e,f,g up to 2019/38
33	093848	648R06300	RELAY FINDER 66.82.8.230.0001	RELÈ FINDER 66.82.8.230.0001	d,e,f,g from 2019/39
34	096636	694R00502	EMC FILTER	FILTRO ANTIDIST. 411.13.2010	d,e,f,g
35	095282	503R29200	ARMOURED HEATER FIXING BRACK.	FASCETTA DI FISSAGGIO RESISTE.	d,e,f,g
36		503R39400	COMMON PART AIR CONVEYOR BT	CONVOGLIATORE ARIA	d,e,f,g
37	095317	503R26701	EVAPORATOR COVER FREEZER	PROTEZIONE EVAPORATORE	d,e,f,g
38	095283	503R29400	ALUMINUM TIE	FASCETTA PER RESISTENZA	d,e,f,g
39	095355	617R16601	ARMOURED HEATER COUNTER FZ	RESISTENZA	d,e,f,g
40	095356	830R12901	EVAPORATOR 12RH 25X22 H700	EVAPORATORE BT	d,e,f,g
41	095357	515R33701	PIPE FROM COND. TO CM. (FREEZER)	SERPENTINA DI EVAP. ACQUA DI CON.	d,e,f,g
42	095666	639R16600	TERMINAL BOARD 8 PINS W/ GROUND	MORSETTIERA 8 POLI CON TERRA	d,e,f,g
43					

HP range

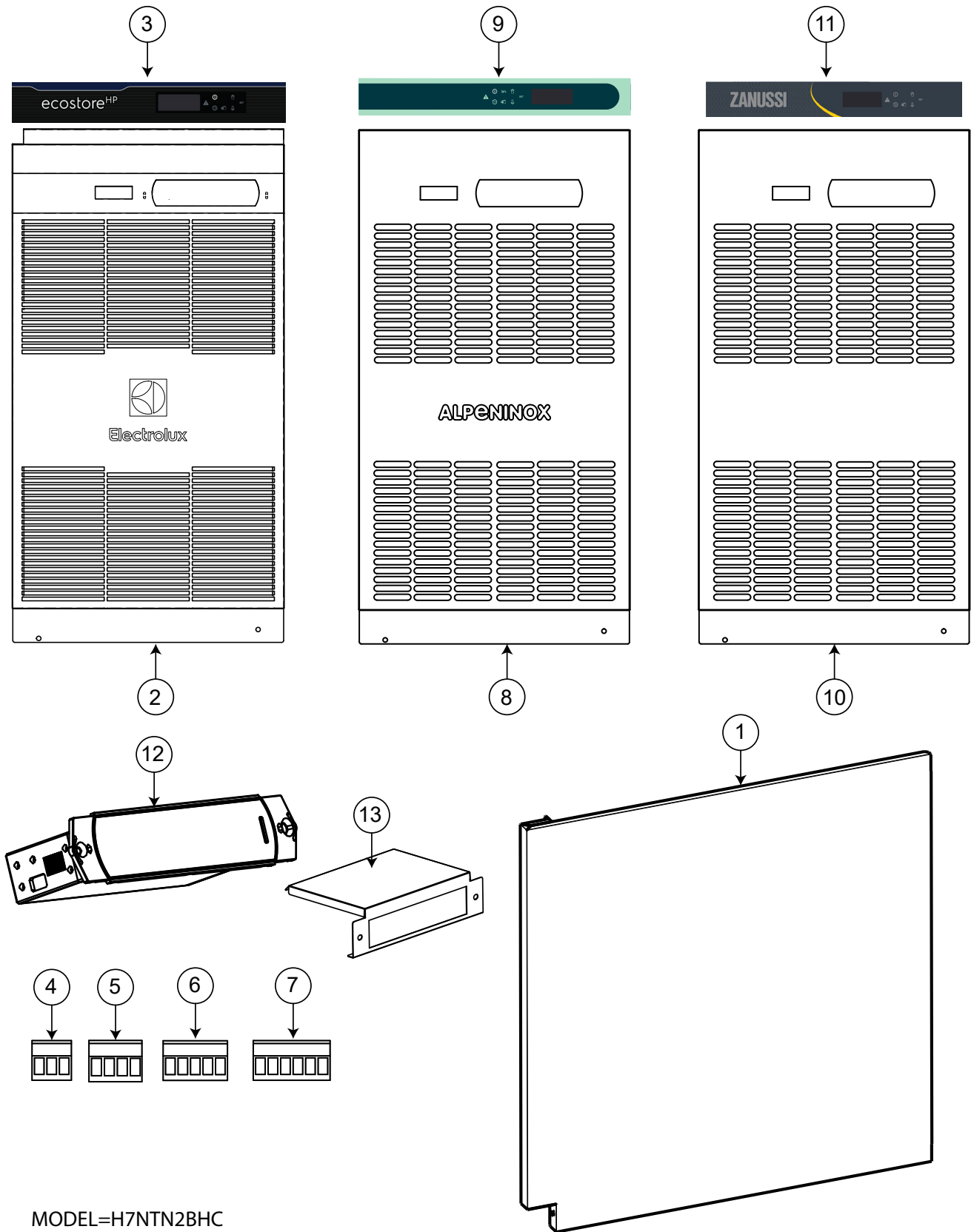

MODEL=H7NTN2BHC
 H7NTN3BHC
 H7NTN4BHC
 H7NBT2BHC
 H7NBT3BHC

Concept line range

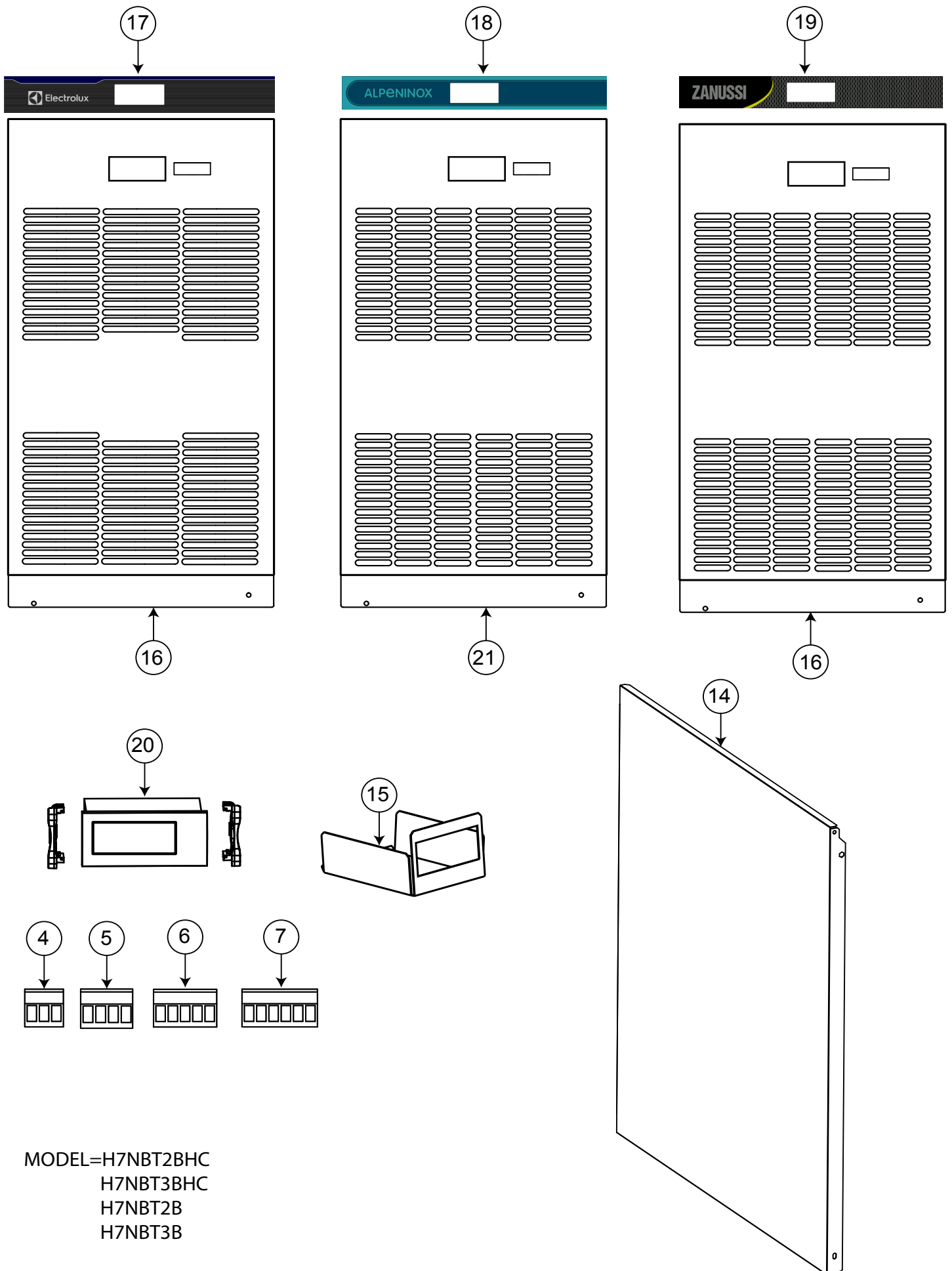

MODEL=H7NBT2BHC
 H7NBT3BHC
 H7NBT2B
 H7NBT3B

Pos	Code	Factory code	Description	Descrizione	Ref/notes
			Control panel	Pannello di controllo	
1	095232	503R25000	EXTERNAL SIDE PANEL H700	PANNELLO ESTERNO	a,b,c,d,e
1	095631	0503R62601	EXTERNAL SIDE PANEL H700 HP	PANNELLO ESTERNO HP	d (R290),e (R290),f,g
2		833R38402	SCREEN PRINTED ASSEMBLY ELEC.	PANNELLO ELECTROLUX ASS.	a,b,c (ELECTROLUX) HP
3	095233	755R10400	STICKER CONTROL ELUX REFRIG.	MEMBRANA CON TASTI ELUX TN	a,b,c (ELECTROLUX) HP
3	095268	755R11100	STICKER CONTROL ELUX FREEZER	MEMBRANA CON TASTI ELUX BT	d,e (ELECTROLUX) HP
4	095241	639R16800	CONNECTOR 6 to7 2.5/3 ST PASSO 5	CONNETTORE 6 to7 2.5/3 ST P. 5	
5	091682	0639R04400	CONNECTOR 9 to12 2.5/4 ST PASSO 5	CONNETTORE 9 to12 2.5/4 ST P. 5	
6	095242	639R16700	CONNECTOR 1 to 5 2.5/5 ST PASSO 5	CONNETTORE 1 to 5 2.5/5 ST P. 5	
6	095243	639R16900	CONNECTOR 11to15 2.5/5 ST PASSO 5	CONNETTORE 11to15 2.5/5 ST P. 5	
7	095244	0639723400	CONNECTOR 5 to 10 2.5/6 ST PASSO 5	CONNETTORE 5 to 10 2.5/6 ST P. 5	
8		503R26100	CTRL PANEL COUNTER HP PREM	PANNELLO CONTROLLO APX	a,b,c (ALPENINOX) HP
9	095234	755R10500	STICKER CONTROL APX REFRIG.	MEMBRANA CON TASTI APX TN	a,b,c (ALPENINOX) HP
9	095269	755R11200	STICKER CONTROL APX FREEZER	MEMBRANA CON TASTI APX BT	d,e (ALPENINOX) HP
10	095336	503R26002	CTRL PANEL COUNTER HP PREM	PANNELLO CONTROLLO ZANUSSI	a,b,c (ZANUSSI) HP
11	095270	755R10600	STICKER CONTROL ZANUSSI REFRIG.	MEMBRANA CON TASTI ZANUSSI TN	a,b,c (ZANUSSI) HP
11	095235	755R11300	STICKER CONTROL ZANUSSI FREEZ.	MEMBRANA CON TASTI ZANUSSI BT	d,e (ZANUSSI) HP
12	095252	646R13500	TERMOREG.EASYWIDE 115/230VAC	TERMOREG.EASYWIDE 115/230VAC	a,b,c,d,e HP
13	095343	503R45400	EASY WIDE COVER	PROTEZIONE TERMOREGOLATORE	a,b,c,d,e HP
14	095232	503R25000	EXTERNAL SIDE PANEL H700	PANNELLO ESTERNO	a,b,c,d,e
14	095631	0503R62601	EXTERNAL SIDE PANEL H700 HP	PANNELLO ESTERNO HP	d (R290),e (R290),f,g
15	095565	503R68400	IR33 COVER COUNTERS C.L.	PROTEZIONE TERMOREGOLATORE	d,e,f,g CL
16		509R24100	CTRL PANEL CL H700 ELX "R" FZ	PANNELLO CONTROLLO CL FREEZER	d,e,f,g CL (ELUX)
17	095668	755R14601	STICKER CONT. CL FR IR33 ELX L-R	MEMBRANA ELX BT IR33 CL	d,e,f,g CL (ELUX)
*	092134	147017028	NEOPRENE	NEOPRENE ESP.CELL.CHIUSE 8X10	
18	095667	755R14500	STICKER CONT. CL FR IR33 APX L-R	MEMBRANA APX BT IR33 CL	d,e,f,g CL (APX)
19	095615	755R14700	STICKER CONT. CL FR IR33 ZAN L-R	MEMBRANA ZAN BT IR33 CL	d,e,f,g CL (ZAN)
20	093434	646R11101	TERMOREGOLAT. IR33 IMEL1J0559	CONTROLLORE IR33	d,e,f,g CL - Up to 2023/16 order KIT 097750, see TB VTX2023_08
20	097579	855R18401	TERMOREGOLAT. IJF SMALL	CONTROLLORE IJF SMALL	d,e,f,g CL - From 2023/17 Up to 2024/19
20	09A1NM	855R0BY00	TERMOREGOLAT. IJF SMALL	CONTROLLORE IJF SMALL	d,e,f,g CL - From 2024/20
21		509R22800	CTRL PANEL CL H700 "R" FZ	PANNELLO CONTROLLO CL FREEZER	d,e,f,g CL
22					
23					
24					