

**BLAST CHILLER- FREEZER
ABBATTITORI CONGELATORI**

SKCH 6GN 1_1

Type Reference	Ref	Page	Description	note
SKCH30B	a	3_4_6_9	BCF 30KG 380V BUILT IN 50 HZ	
SKCH30R	b	3_4_7_9	BCF 30KG 380V REMOTO 50/60HZ	

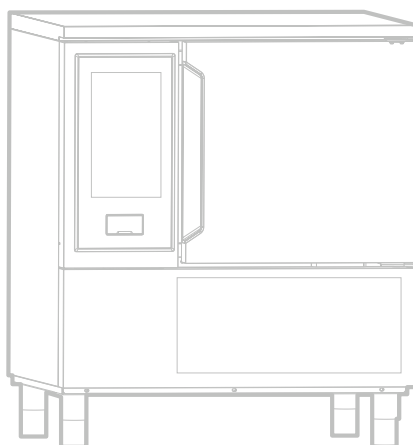

Index	Page
Descriptions type ref/Descrizione el Type refence	2
Exploded view internal components/ Vista esplosa componenti interni	3
Exploded view Doors/ Vista esplosa porte	4
Spare part list/Lista ricambi	5
Exploded view cooling unit/ Vista esplosa gruppo refrigerante	6
Exploded view cooling unit remote/ Vista esplosa gruppo refrigerante remoto	7
Spare part list/Lista ricambi	8
Control panel/pannello comandi	9
Spare part list/Lista ricambi	10
Maintenance kit/Kit di manutenzione	11

...**Bold**= last change/Grassetto =ultima modifica

V = Vital spare part/Ricambio vitale

W&T = Wear&Tear and Consumable/Ricambio usurabile e consumabile

S = Suggested/Ricambio suggerito

Bold=last change / Grassetto =ultima modifica

Rev. 2

From Ser. Nr.... Up to Ser. Nr....	Ed. 2019-03 Updated 2019-06	Page: 1	Doc No:595R42400
---------------------------------------	--------------------------------	---------	-------------------------

How to put in relation the “Type Ref.” reported on the data plate with the “Type reference” reported on the front page of the Spare Part Catalogue:

The “Type Ref.” represents a group of models/brands all with similar technical features, hence possible to be reported under the same scheme in terms of exploded views.

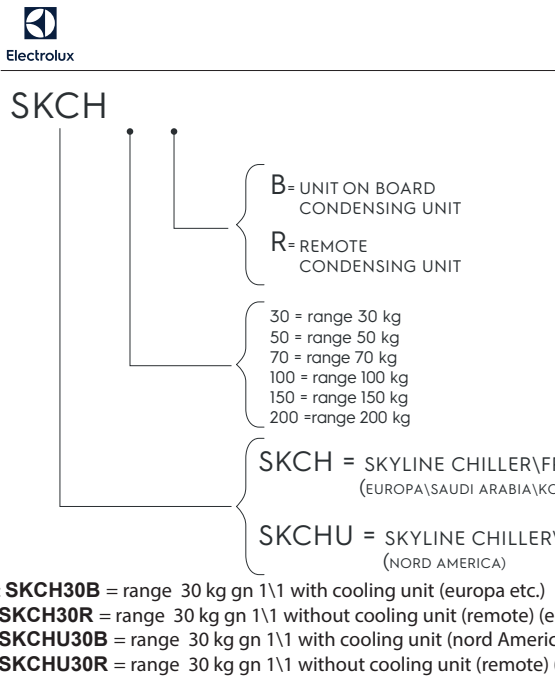

Find below an identification example: SKCH30B

F.Mod. PNC 9VTX.....	Comm.Model Ser.Nr.....	Type Ref. SKCH30B	2019
W.Tot. kW	Volt..... Hz.....	Cyclopentane	Total Current A
Evaporation Heater El. kW	Class x	GWP	CO2-eq t
Lighting W	Cap. Refrigerant		Kg
Defrost Power kW	Heating power kW		
NF nominal Charge			
Rated Pressure Mpa		CE	WEEE
IPX4			
Electrolux Professional SPA - Viale Treviso, 15 - 33170 Pordenone (Italy)			

For the right spare code identification follow the steps:

1. Type in the website the PNC reported on the data plate.
2. The website will automatically display this spare part catalogue.
3. The spare part code at this point is referenced through the “Type reference” as from the front page by the relevant “Ref”.

Come mettere in relazione il “Type Ref.” Riportato sulla targhetta caratteristica con il “Type reference” riportato sul frontespizio del catalogo ricambi:

Il “Type Ref.” Rappresenta un gruppo di modelli/marchi con simili caratteristiche tecniche, ossia possibili da rappresentare con il medesimo schema in termini di vista esplosa.

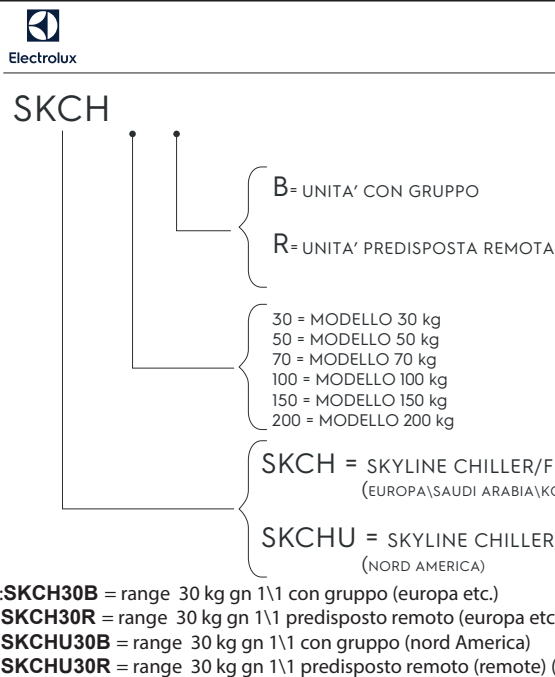

Qui di seguito un esempio di identificazione: SKCH30B

F.Mod. PNC 9VTX.....	Comm.Model Ser.Nr.....	Type Ref. SKCH30B	2019
W.Tot. kW	Volt..... Hz.....	Cyclopentane	Total Current A
Evaporation Heater El. kW	Class x	GWP	CO2-eq t
Lighting W	Cap. Refrigerant		Kg
Defrost Power kW	Heating power kW		
NF nominal Charge			
Rated Pressure Mpa		CE	WEEE
IPX4			
Electrolux Professional SPA - Viale Treviso, 15 - 33170 Pordenone (Italy)			

Per identificare il corretto codice ricambio procedere con:

1. Digitare nel website il PNC riportato sulla targhetta caratteristica.
2. Il website mostrerà automaticamente questo catalogo ricambi.
3. A questo punto, il codice ricambio è identificabile attraverso il “Type reference” come indicato nel frontespizio sotto la relativa voce “Ref”.

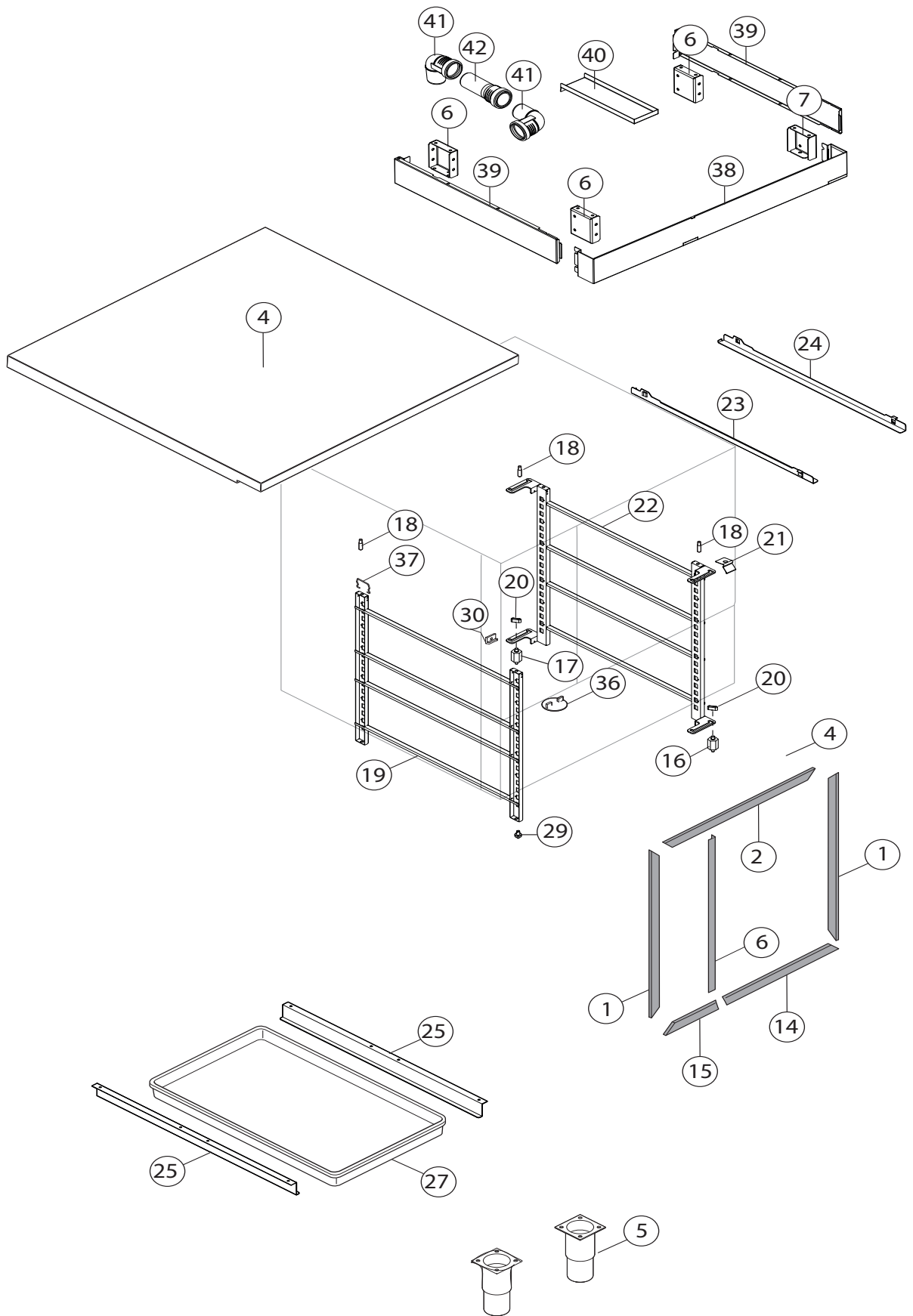

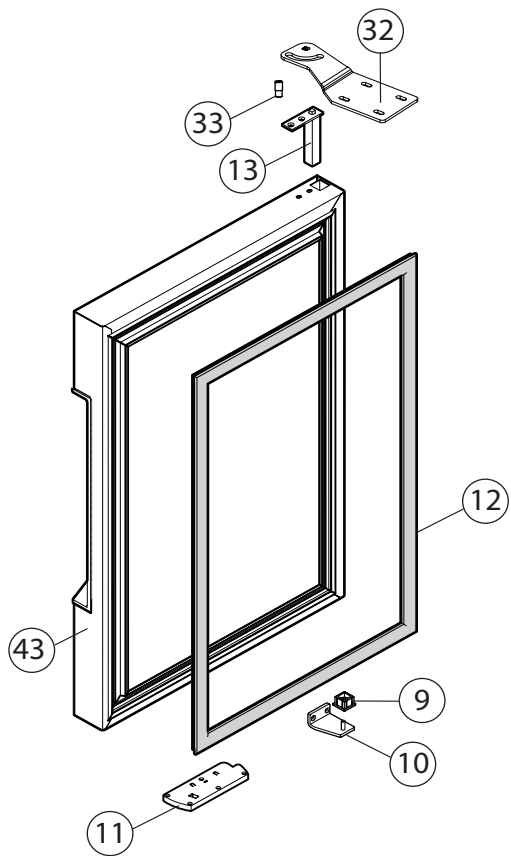

DOOR ELUX LEFT

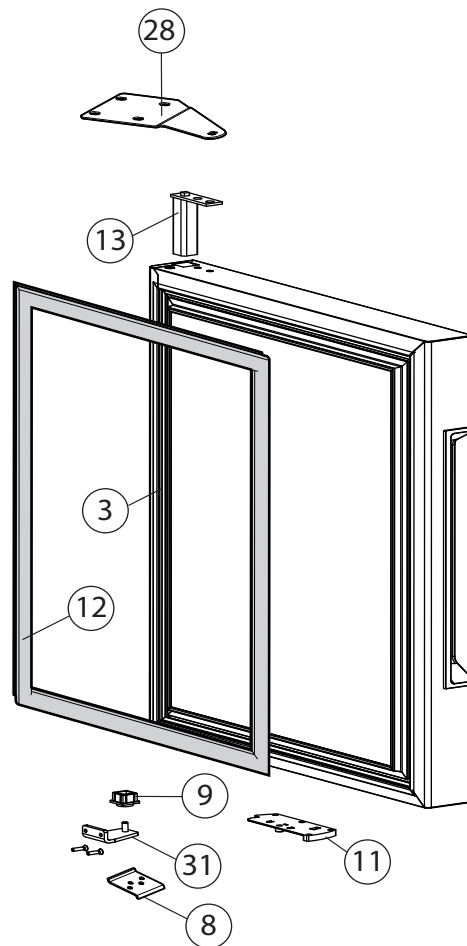

DOOR ELUX RIGHT

DOOR apx/zan RIGHT

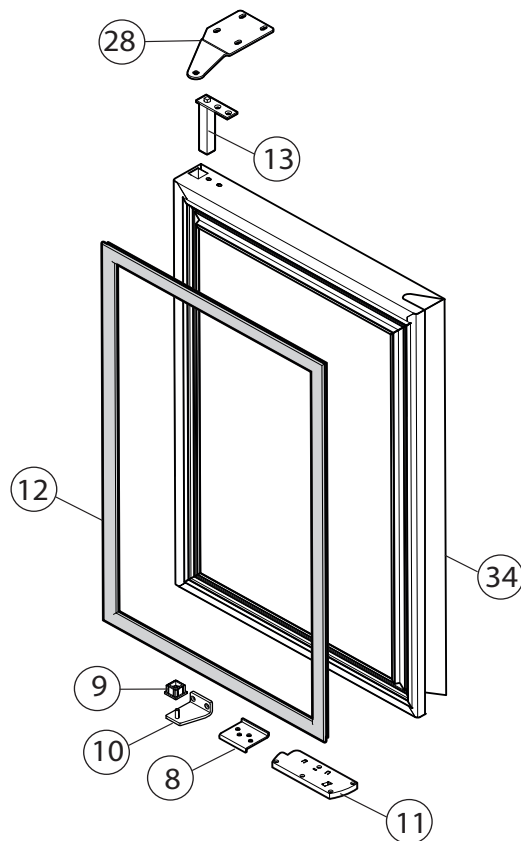

Pos	Code	Factory code	Description	Descrizione	V	W & T	S	Ref/notes
Reference pag.3-4								
1	095982	0543R20101	ASSEMBLY COVER WITH MAGNET - V	CORNICE VERTICALE				
2	096065	0543R23600	ASSEMBLY COVER WITH MAGNET - H	CORNICE ORIZZONTALE SUP.				
3	095918	0835R59602	DOOR FOAMED RIGHT ELUX BCF30	PORTA SCHIUMATA DX 30 kg				ELUX RIGHT
4	095927	0882R16200	TOP MODULE BCF30 JJ	TOP				
5	095926	0882R01200	SUPPORT MOD FEET H150 BCF	SUPPORT PE FORNO				
6	096052	0505R28300	SUPPORT FOR BCF 30 TOWER H100	SUPPORTO PER FORNO FRONTALE				
7	096051	0505R28200	FRONT RIGHT SUPPORT FOR H100					
8	092917	0510789200	LOWER DOOR SUPPORT	PIASTRINA INF.PORTA				
9	081654	0544700601	LOWER DOOR BUSH	BOCCOLA X 1/2P INFERIORE	X			
10	095959	0505R26602	LEFT LOWER HINGE	CERNIERA INFERIORE SX				
11	099909	0835R03800	PLATE DOOR OPEN	ASS. DISP. BLOCCO PORTA APERTA				
12	095985	0548R13300	DOOR MAGNETIC GASKET BCF30	GUARNIZIONE PORTA	X	X		
13	083876	0835714501	UPPER HINGE DOOR	CERNIERA CON MOLLA PERNO RIB.	X	X		
14	096061	0543R21400	ASSEMBLY COVER WITH MAGNET - H	CORNICE ORIZZONTALE INF. SX				
15	096064	0543R21600	ASSEMBLY COVER WITH MAGNET - H	CORNICE ORIZZONTALE INF. DX				
16	093935	0514R13301	FRONT RACK SUPPORT	SUPPORTO GUIDE ANT. BCF				
17	093936	0514R13401	BACK RACK SUPPORT	SUPPORTO GUIDE POST. BCF LW				
18	089970	0518713900	PIN FOR RACK	PERNO PER CARTER M6 BCF				
19	096036	0833R47000	GRID ASSEMBLY	ASS. CREMAGLIERA 30KG LW				
20	093939	0530R04700	LOCK NUT FOR RACK	CHIAVETTA DI SERRAGGIO		X		
21	093962	0514R16300	SPRING FOR RACK	MOLLA BLOCCO CREMAGLIERE		X		
22	095931	0833R47100	GRID ASSEMBLY	CREMAGLIERA				
23	093862	0501R67301	LEFT GUIDE FOR RACK	GUIDA BCF 30-50KG SX				
24	093861	0501R67401	RIGHT GUIDE FOR RACK	GUIDA BCF 30-50KG DX				
25	089977	0510774302	BASIN GUIDE	GUIDA PER BACINELLA EST				
27	080803	0242452410	BLACK CONDESATE BASIN	BACINELLA RACC.COND.NERO		X		
28	096053	0505R29500	UPPER HINGE DOOR	CERNIERA SUP.X ABB. SX				
29	095977	0518R09300	LOWER PIN FOR BCF JJ SRUCTURE	PERNO INFERIORE STRUTTURA				
30	093938	0546R29300	RACK SUPPORT	APPOGGIO PER CREMAGLIERE		X		
31	095960	0505R26702	RIGHT LOWER HINGE BCF30 JJ	CERNIERA INFERIORE DX				
32	096040	0503R50400	LEFT UPPER HINGE WITH STOPPER	CERNIERA SUPERIORE SX				
33	096056	0514R28000	STUD FOR DOOR STOP BCF JJ	PERNO PER FERMO PORTA SUP				
34	096102	0882R44301	DOOR LEFT ZAN/APX ASS.Y	ASS. PORTA SX APX/ZAN				APX/ZAN LEFT
36	093934	0546R27300	CAVITY PLUG	TAPPO FONDO BCF	X	X		
37	095966	0514R28700	LOCKING SPRING BCF JJ	MOLLA PE STRUTTURA SX				
38	096046	0503R94300	FRONT PANEL STAKING KIT BCF30	PANNELLO FRONTALE				
39	096047	0503R94400	LATERAL SIDE PANEL STAKING KIT	PANNELLO LATERALE				
40	096045	0503R94200	WATER DISCHARGE COLLECTOR	BACINELLA DI SCARICO FORNO				
41	096057	0515404U00	ELBOW DRAIN PIPE	CURVA DIA 50 90° - PP		X		
42	096035	0544402200	RIGHT DRAIN PIPE	TUBO DIA 50 L150 - PP		X		
43	096098	0882R11400	DOOR ELUX LEFT ASS.Y	ASS. PORTA SX				ELUX LEFT

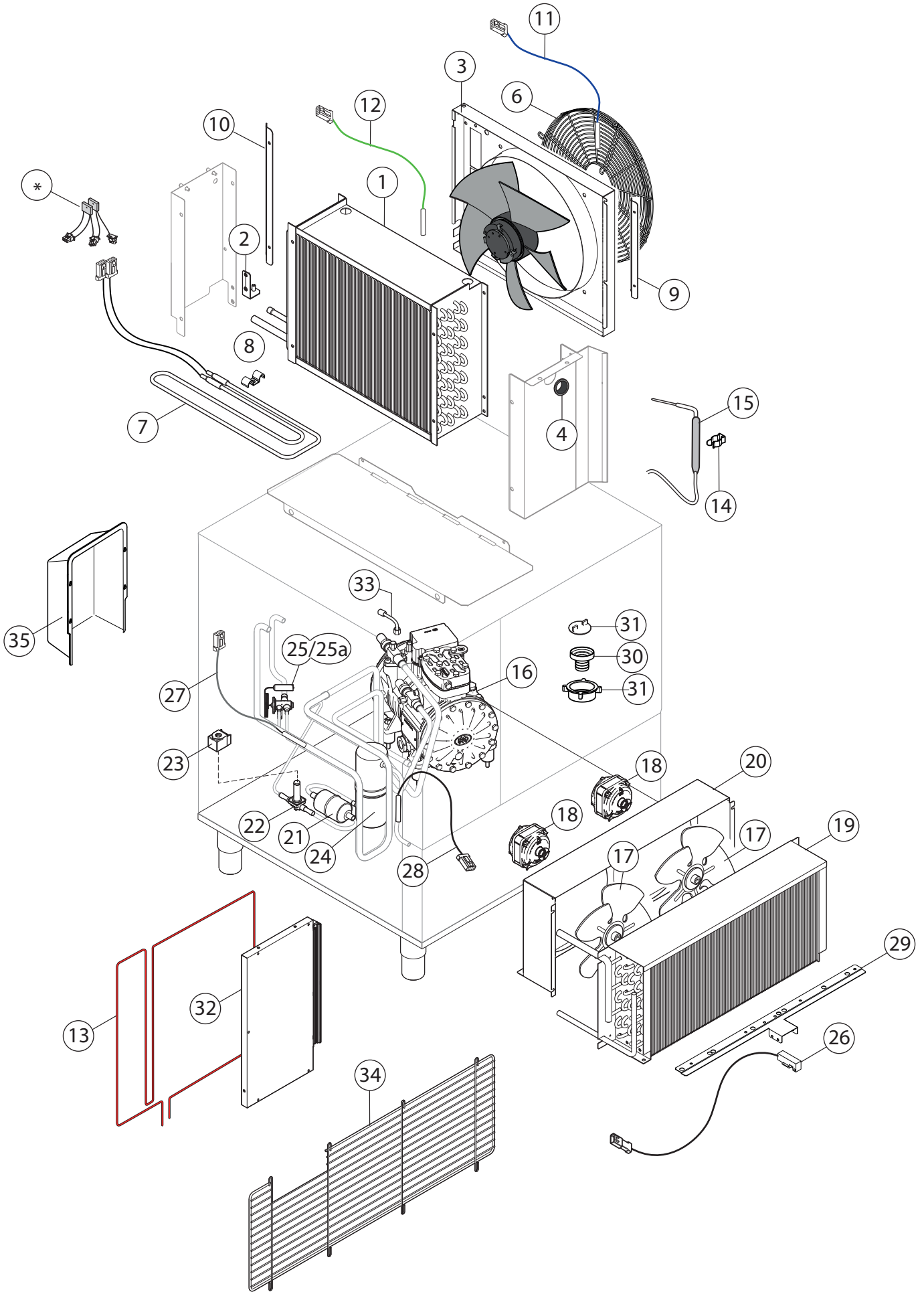

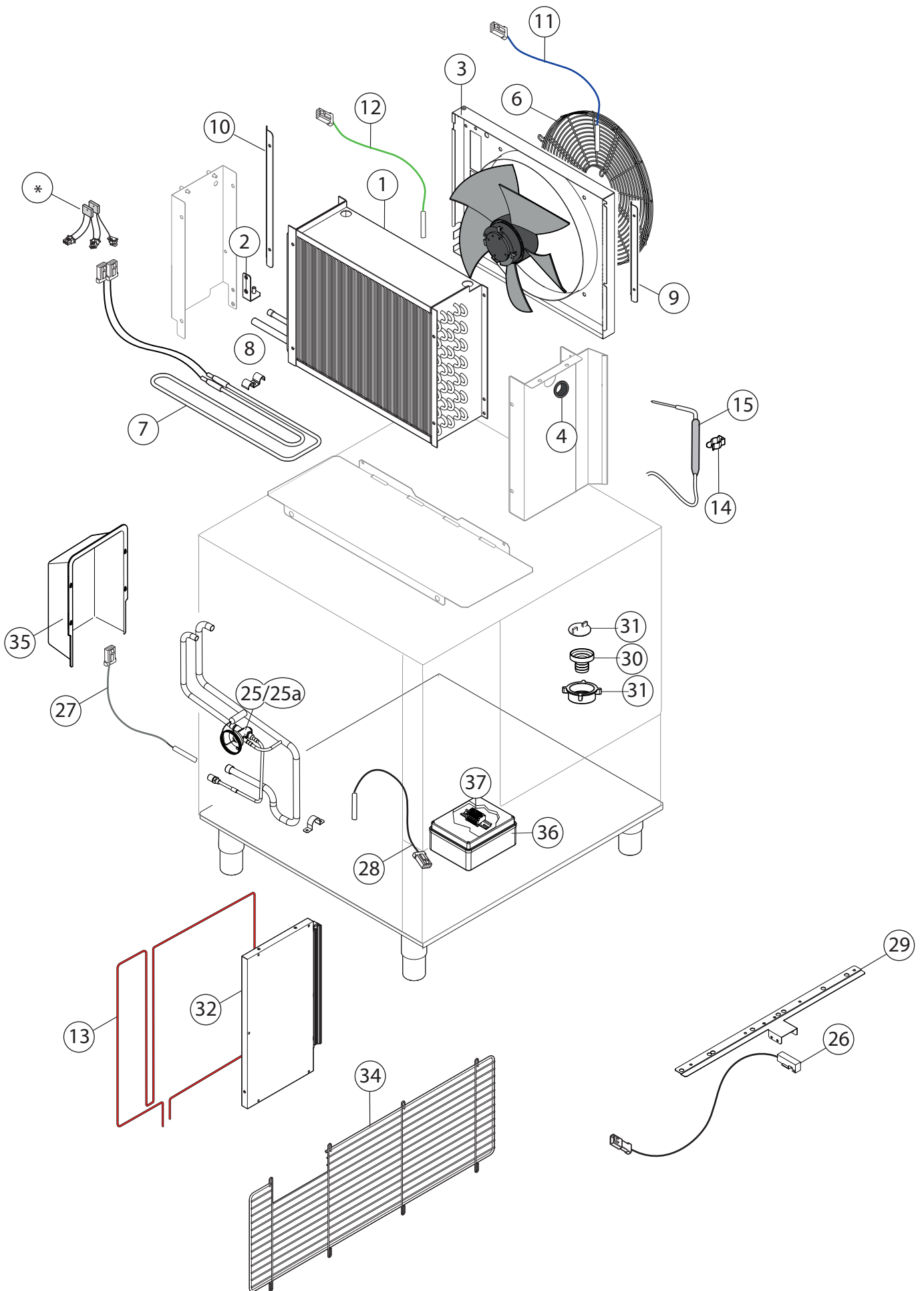

Pos	Code	Factory code	Description	Descrizione	V	W & T	S	Ref/notes
Reference pag.6-7								
1	095913	0830R14201	FINNED COIL EVAPORATOR BCF 30 KG	EVAPORATORE	X			
2	095958	0505R13900	CARTER SUPPORT	STAFFA CARTER 30KG				
3	096042	0503R90402	CARTER FAN	CARTER VENTILATORI X BCF 30KG				
4	082096	0639704600	HOSE CLAMP Hole 17.5 mm	PASSACAVO_ FORO 17.5mm		X		
5	096011	0682R11801	CAVITY FAN Ø350	VENTILATORE CELLA Ø350	X			
6	095963	0514R26701	PROTECTION FAN_GRID DIAM.380	PROTEZIONE VENTILATORE DIAM.380				
7	095930	0856R35500	HEATING ELEMENT - EVAPORATOR	RESISTENZA EVAPORATORE 800W		X		
8	048429	0506675402	FIXING HEATING ELEMENT	SQUADR.FISS.RESIST.				
9	096062	0504R06000	FRONT AIRFLOW DIFFUSER	DIFFUSORE ARIA FRONTALE				
10	095955	0503R76203	REAR AIRFLOW DIFFUSER	DIFFUSORE ARIA POSTERIORE				
11	096003	0646R19002	CELL PROBE "BLUE"	SONDA 6X20 BLU 'CELL'	X	X		
12	096004	0646R19102	EVAPORATOR PROBE "GREY"	SONDA 6X40 EVAP		X		
13	095990	0617R18301	HEATING ELEMENT CABLE L=3165MM	RESISTENZA SBRINAMENTO	X	X		
14	091800	0639730101	HOOK FRO MEET PROBE	GANCIO IN AISI 304				
15	096007	0646R19402	MEET PROBE 3 SENSOR	SPILLONE CONICO 3 PUNTI		X		
16	088473	0684723501	COMP. DORIN H181CS	COMP. DORIN H181CS	X			a
17	094955	0511R01900	CONDENSER FAN	VENTOLA ASPIRANTE ALLUM. 254X31	X			a
18	096012	0682R12400	CONDENSER MOTOR FAN	VENTILATORE 230-240V/50-60 HZ	X			a
19	095912	0830R14103	FINNED COIL CONDENSER	CONDENSATORE	X			a
20	095948	0503R49300	CONDENSER CONVEYOR	CONVOGLIATORE CONDENSATORE				a
21	088201	0646725601	FILTRO GAS DML052	FILTRO DCL083S 10MM	X	X		a
22	088030	0646746400	EVR 6 BODY SOLENOID VALVE	CORPO VALV. EVR 6	X	X		a
23	085847	0646729100	EVR 6 COIL SOLENOID VALVE	BOB.CLIP ZB15 PARKER EVR6	X	X		a
24	087758	0805749401	RECEIVER	RICEVITORE DI LIQ. A SALD. 0,88 L				a
25	088475	0646754601	EXPANSION VALVE	TUBE,RANGE NL,-40/-15,MOP-10 OR.6	X			
25a	095939	011008R010	INSULATION FOR THERMOS. VALVE	ISOLAMENTO VALVOLA TERMOSTAT.		X		Diam. 15
25a	095938	0110067003	INSULATION FOR THERMOS. VALVE	ISOLAMENTO VALVOLA TERMOSTAT.		X		Diam. 35
26	096002	0640R04101	DOOR MICRO SWITCH	MICROINTERR. PORTA	X			
27	096005	0646R19201	SUCTION PROBE "GREEN"	SONDA ASPIRAZIONE VERDE	X	X		
28	096006	0646R19301	CONDENSER PROBE "BLACK"	SONDA CONDENSATORE NERA	X	X		
29	096041	0503R73502	SUPPORT FOR MICROINT. STEM E511	SUPPORTO MICRO PORTA				
30	094256	0546R26200	RUBBER SUPPORT	PORTAGOMMA		X		
31	094257	0546R26900	NUT 1'1/2	GHIERA 1'1/2		X		
32	095917	0835R59203	FOAMED PANEL BCF 30 JJ	PANNELLO SCHIUMATO				
33	096034	0525710600	SERVICE VALVE PIPE	TUBO CON VALVOLA DI RICARICA	X			
34	095964	0514R26804	REAR PROTECTIVE GRID BCF50 JJ	GRIGLIA POSTERIORE		X		
35	095961	0505R29301	SPACER PROTECTION	DISTANZIALE POSTERIORE BCF LW		X		
36	096068	0639R19700	ELECTRICAL BOX CONNECTION REM.	SCATOLA GEWISS GW44276 IP56				b
37	096071	0639R20000	CLAMP TO CONNECTION REM	MORSETTIERA SCATOLA REMOTA JJ				b
*	096171	0147300900	AMERICAN CANVAS TAPE M50XMM48	NASTRO TELA PLAST. M50XMM48			X	
*	095768	0147017034	PVILENE INSULATION TAPE; 50X3SP	NASTRO 3M389 NERO (MM19 X 50MT)			X	

* = On demand

Pos	Code	Factory code	Description	Descrizione	V	W & T	S	Ref/notes
Reference pag.9								
1	0CK030	0546400U01	DRAWER USB SUPPORT	CKM SEDE USB		X		
2	0CK031	0543401P02	GASKET DRAWER USB SUPPORT	GUARNIZIONE SEDE USB		X		
3		0506405M00	PANEL HOOK	GANCIO PANNELLO				
4	0CK033	0675401G00	ON/OFF BOARD	SCHEDA ON/OFF	X			
5	0CK034	0673400900	DISPLAY JDI 7"	DISPLAY JDI 7" TP RESISTIVO	X			
6	0CK036	0675401J01	BRIDGE BOARD	SCHEDA CONNESSIONE DISPLAY	X			
6a	0CK035	0675401H00	CORE BOARD DAVE	TOUCH	X			
7	0C9603	0638F00800	WIRING USB	CAVO USB		X		
8	0CK039	0655400000	SPEAKER VISATON	ALTOPARLANTE		X		
9	0CK330	0675401L00	WIRING SPEAKER	CAVETTO CONNESSIONE SPEAKER		X		
10	0CK045	0675401Q00	WIRING ON/OFF BOARD	CAVETTO ON-OFF TOUCH	X	X		
11	0CK040	0543401N01	PLASTIC FRAME TOUCH	PANNELLO IN PLASTICA				
12	0CK041	0546400V01	USB COVER	SPORTELLINO USB ELUX		X		
13	0CK080	0830409103	ASS. TOUCH UI ELUX	PANNELLO COMPLETO UI				
14	095934	0755R13901	ADHESIVE DECOR A ELUX TOUCH	MEMBRANA ADESIVE ELUX		X		order also N° 11
14	095935	0755R16101	ADHESIVE DECOR A ZAN TOUCH	MEMBRANA ADESIVE ZAN		X		order also N° 11
14	096058	0541401V01	ADHESIVE DECOR TO BRAND	MEMBRANA ADESIVE TO BRAND		X		order also N° 11
14	095936	0755R16201	ADHESIVE DECOR ALPEN	MEMBRANA ADESIVE APX		X		order also N° 11
15	096078	0882R15203	ELECTRICAL BOX COMPLETE built in	SCATOLA ELETTRICA COMPLETA				a
15	096081	0882R72001	ELECTRICAL BOX COMPLETE rem	SCATOLA ELETTRICA COMPLETA				b
16	093848	0648R06300	RELAY	RELE' FINDER	X	X		
17	088477	0648807300	CONTACTOR	CONTATTORE K3-10N 230V 50/60HZ	X	X		a
18	096067	0639R18001	MAIN TERMINAL BLOCK	BLOCCHETTI DI CONNESSIONE ELET.				
19	095933	0652R02400	GLASS FUSE 10A T 5X20	FUSIBILE IN VETRO 10A T 5X20	X	X		
20	084987	0694700800	FILTRO PROCOND	FILTRO R.F.I.		X		
21	095639	0648R10000	POWER SUPPLY 12V 30W	SCHEDA DI POTENZA 12V 30W	X			
22	096010	0648R08602	ACU PETRA BCF	SCHEDA PRINCIPALE "PETRA"	X			
23	0CK161	0541401D00	PROTECTION COMAND PANEL	PROTEZIONE PANNELLO COMANDI				
24	0CK032	0514405001	SPRING FOR DRAWER USB	MOLLA PER SPORTELLINO		X		
25	095946	0503R48402	CONTROL PANEL BCF30 JJ	PANNELLO DI CONTROLLO				
26	095950	0503R55503	CONDENSER PANEL BCF30 JJ ELUX	PANNELLO CONDENSATORE				ELUX
26	096043	0503R91001	CONDENSER PANEL BCF30 ZAN/APX/	PANNELLO CONDENSATORE				ZAN/APX TO BRAND
27	006610	0648806900	RELE'62.838.230.0009+ATT.BARRA DIN	RELE' CONNESSIONE N REMOTA	X	X		b
28								

Spare Part Code KIT	Description KIT	Spare Part Code	Spare Part Q.ty	Spare part Description	Descrizione Spare part	Ref./ Note
KIT DI MANUTENZIONE - MAINTENANCE KIT						
096166	SKL BCF 30 PM KIT					
		095985	1	DOOR MAGNETIC GASKET BCF30	GUARNIZIONE PORTA	
		095939	2mt	INSULATION FOR THERMOS. VALVE	ISOLAMENTO VALVOLA TERMOSTAT.	Diam. 15
		095938	2mt	INSULATION FOR THERMOS. VALVE	ISOLAMENTO VALVOLA TERMOSTAT.	Diam. 35
		095989	1mt	COIBENTATION PIPES	TUBO ANTICOND. GREY DIAM.16-36	
		095165	1	CLIP OBO 255/3,2 OBO 255.3.2	FERMACAVO OBO 255/3,2 OBO 255.3.2	
		096156	3	SCREW 4,8X70/60 DIN 6928	VITE AUTOFIL. TE FLANG. ZINCATA 4,8X70/60 DIN 6928	