

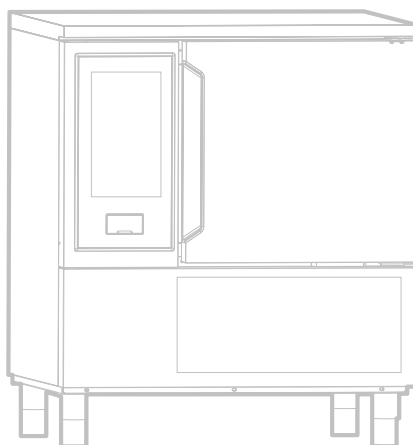

**BLAST CHILLER- FREEZER  
ABBATTITORI CONGELATORI**

**SKCH 6GN 1\_1**

Type Reference	Ref	Page	Description	Note	Frequency
<b>SKCH30B</b>	a	3_4_6_9	BCF 30KG 380V BUILT IN 50 HZ	EU	50HZ
<b>SKCH30B</b>	d	3_4_6_9	BCF 30KG 380V BUILT IN 60 HZ	ROW	60HZ
<b>SKCH30R</b>	b	3_4_7_9	BCF 30KG 380V REMOTO 50/60HZ	EU	50/60HZ
<b>SKCHU30B</b>	c	3_4_6_9	BCF 30KG 208V BUILT IN 60 HZ	USA	60HZ



**Index**

Descriptions type ref/Descrizione el Type refence	<b>Page</b> 2
Exploded view internal components/ Vista esplosa componenti interni	3
Exploded view Doors/ Vista esplosa porte	4
Exploded view cooling unit/ Vista esplosa gruppo refrigerante	5
Exploded view cooling unit remote/ Vista esplosa gruppo refrigerante remoto	6
Control panel/pannello comandi	7
Spare part list/Lista ricambi	9 to 11
Maintenance kit/Kit di manutenzione	12

**Bold**=last change / Grassetto =ultima modifica  
\* on demand= su richiesta

Rev. 8

## How to put in relation the “Type Ref.” reported on the data plate with the “Type reference” reported on the front page of the Spare Part Catalogue:

The “Type Ref.” represents a group of models/brands all with similar technical features, hence possible to be reported under the same scheme in terms of exploded views.

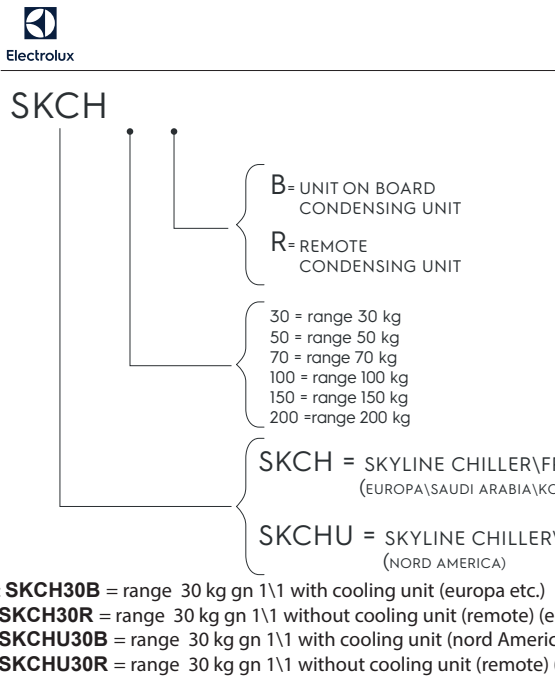

Find below an identification example: SKCH30B

F.Mod. PNC 9VTX.....	Comm.Model Ser.Nr.....	Type Ref. SKCH30B	2019
W.Tot. kW	Volt..... Hz.....	Cyclopentane	Total Current A
Evaporation Heater El. kW	Class x	GWP	CO2-eq t
Lighting W	Cap. Refrigerant		Kg
Defrost Power kW	Heating power kW		
NF nominal Charge			
Rated Pressure Mpa		CE	WEEE
IPX4			
Electrolux Professional SPA - Viale Treviso, 15 - 33170 Pordenone (Italy)			

For the right spare code identification follow the steps:

1. Type in the website the PNC reported on the data plate.
2. The website will automatically display this spare part catalogue.
3. The spare part code at this point is referenced through the “Type reference” as from the front page by the relevant “Ref”.

## Come mettere in relazione il “Type Ref.” Riportato sulla targhetta caratteristica con il “Type reference” riportato sul frontespizio del catalogo ricambi:

Il “Type Ref.” Rappresenta un gruppo di modelli/marchi con simili caratteristiche tecniche, ossia possibili da rappresentare con il medesimo schema in termini di vista esplosa.

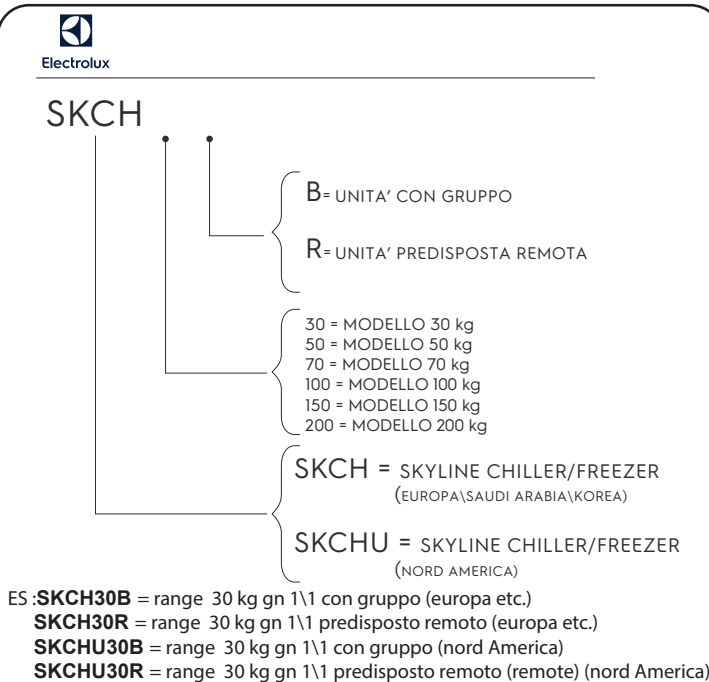

Qui di seguito un esempio di identificazione: SKCH30B

F.Mod. PNC 9VTX.....	Comm.Model Ser.Nr.....	Type Ref. SKCH30B	2019
W.Tot. kW	Volt..... Hz.....	Cyclopentane	Total Current A
Evaporation Heater El. kW	Class x	GWP	CO2-eq t
Lighting W	Cap. Refrigerant		Kg
Defrost Power kW	Heating power kW		
NF nominal Charge			
Rated Pressure Mpa		CE	WEEE
IPX4			
Electrolux Professional SPA - Viale Treviso, 15 - 33170 Pordenone (Italy)			

Per identificare il corretto codice ricambio procedere con:

1. Digitare nel website il PNC riportato sulla targhetta caratteristica.
2. Il website mostrerà automaticamente questo catalogo ricambi.
3. A questo punto, il codice ricambio è identificabile attraverso il “Type reference” come indicato nel frontespizio sotto la relativa voce “Ref”.

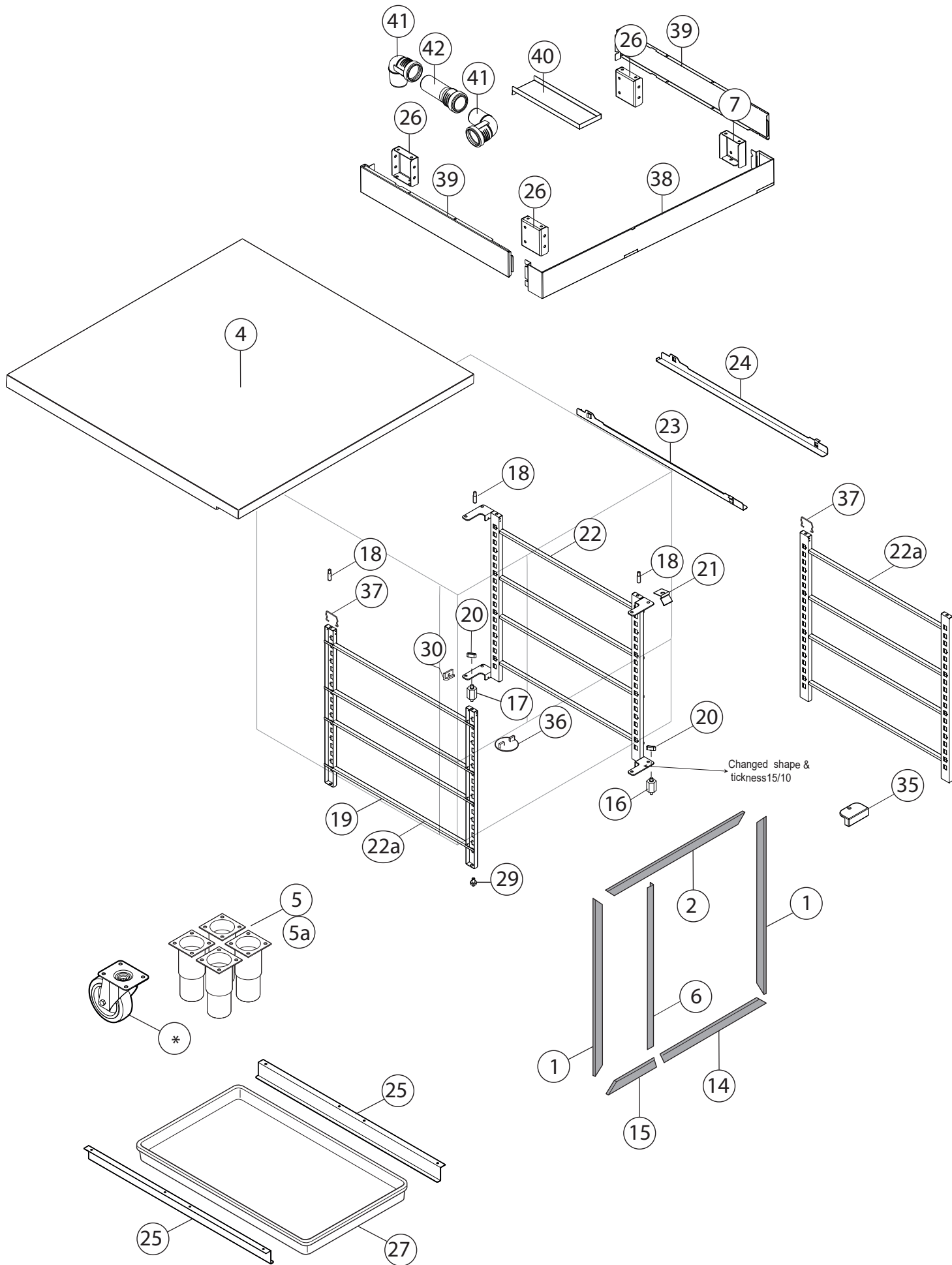

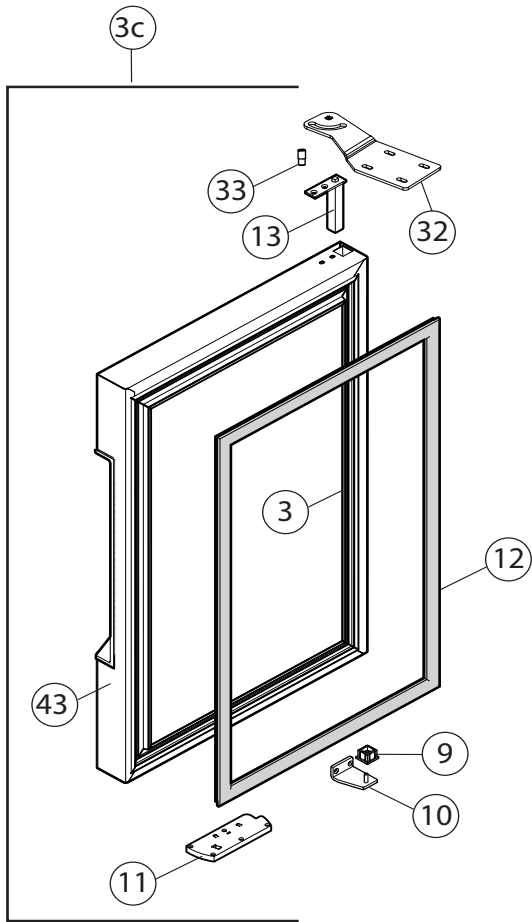

DOOR ELUX LEFT

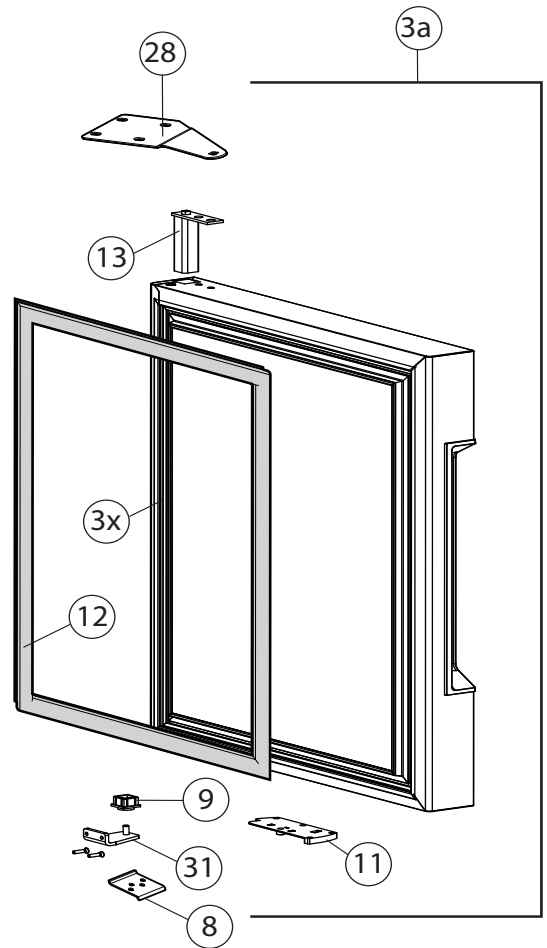

DOOR ELUX RIGHT

DOOR apx/zan LEFT

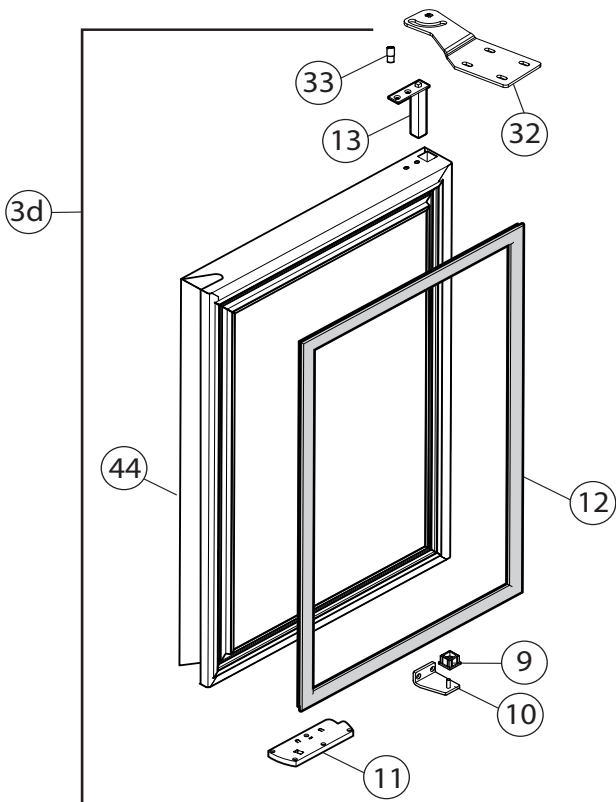

DOOR apx/zan RIGHT

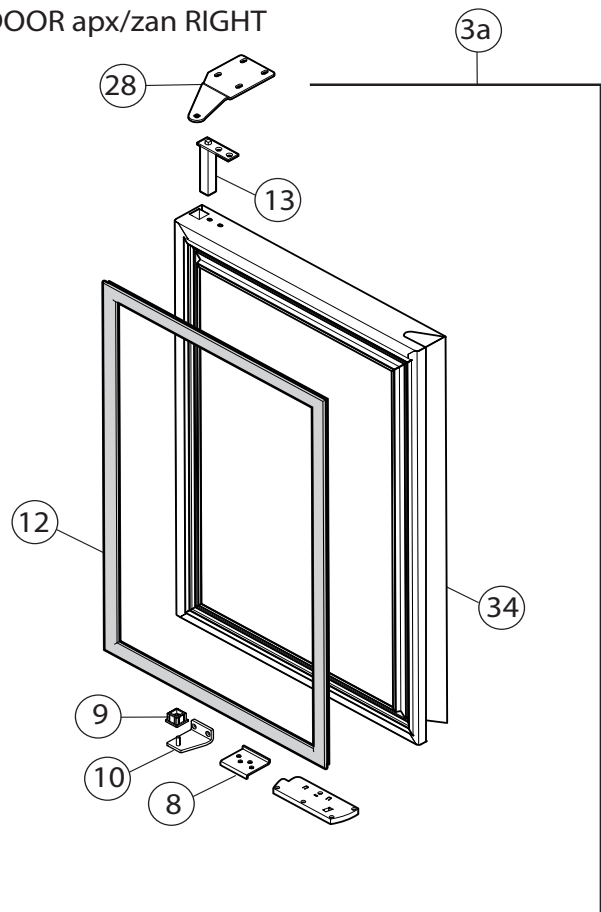

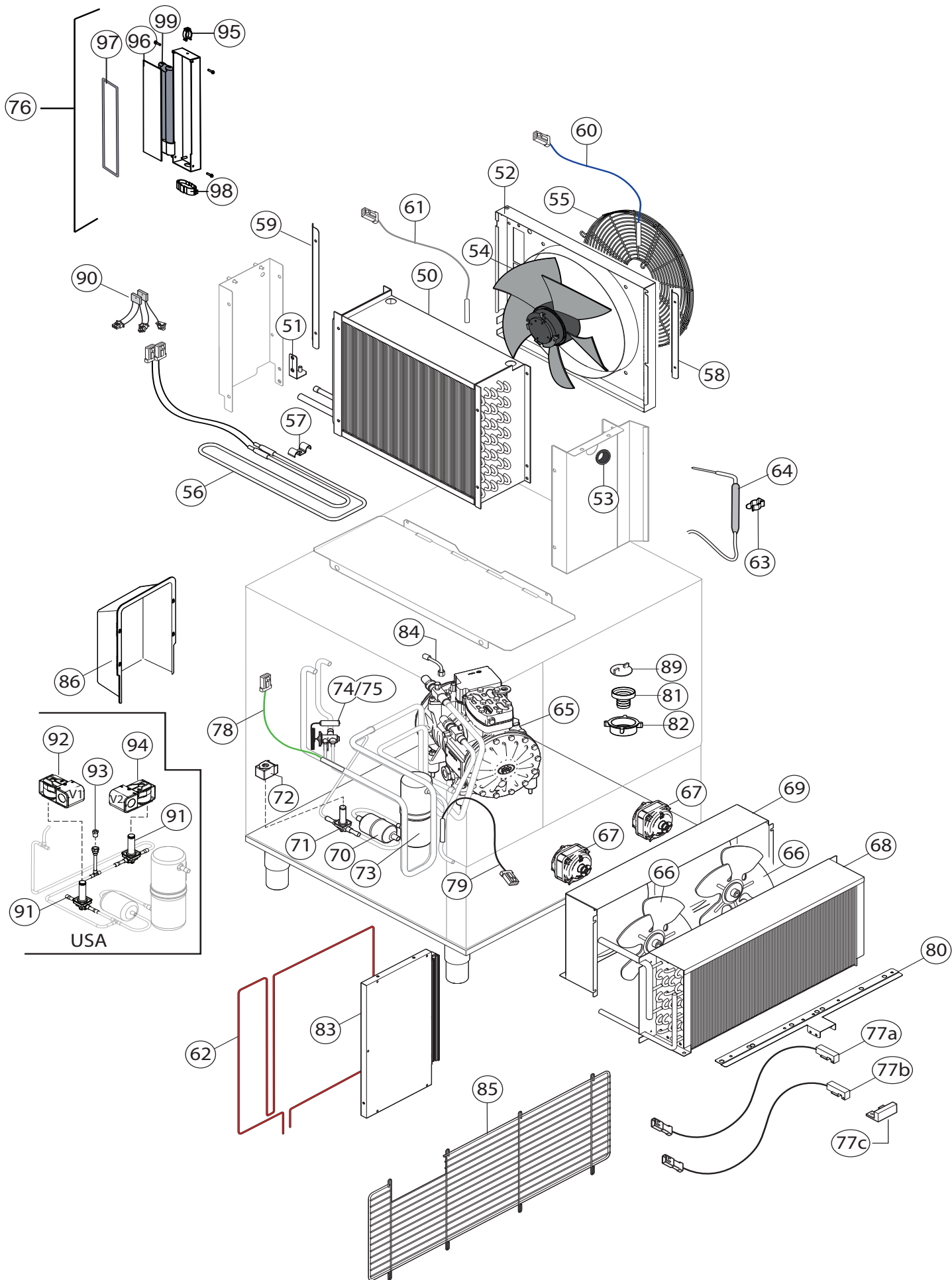



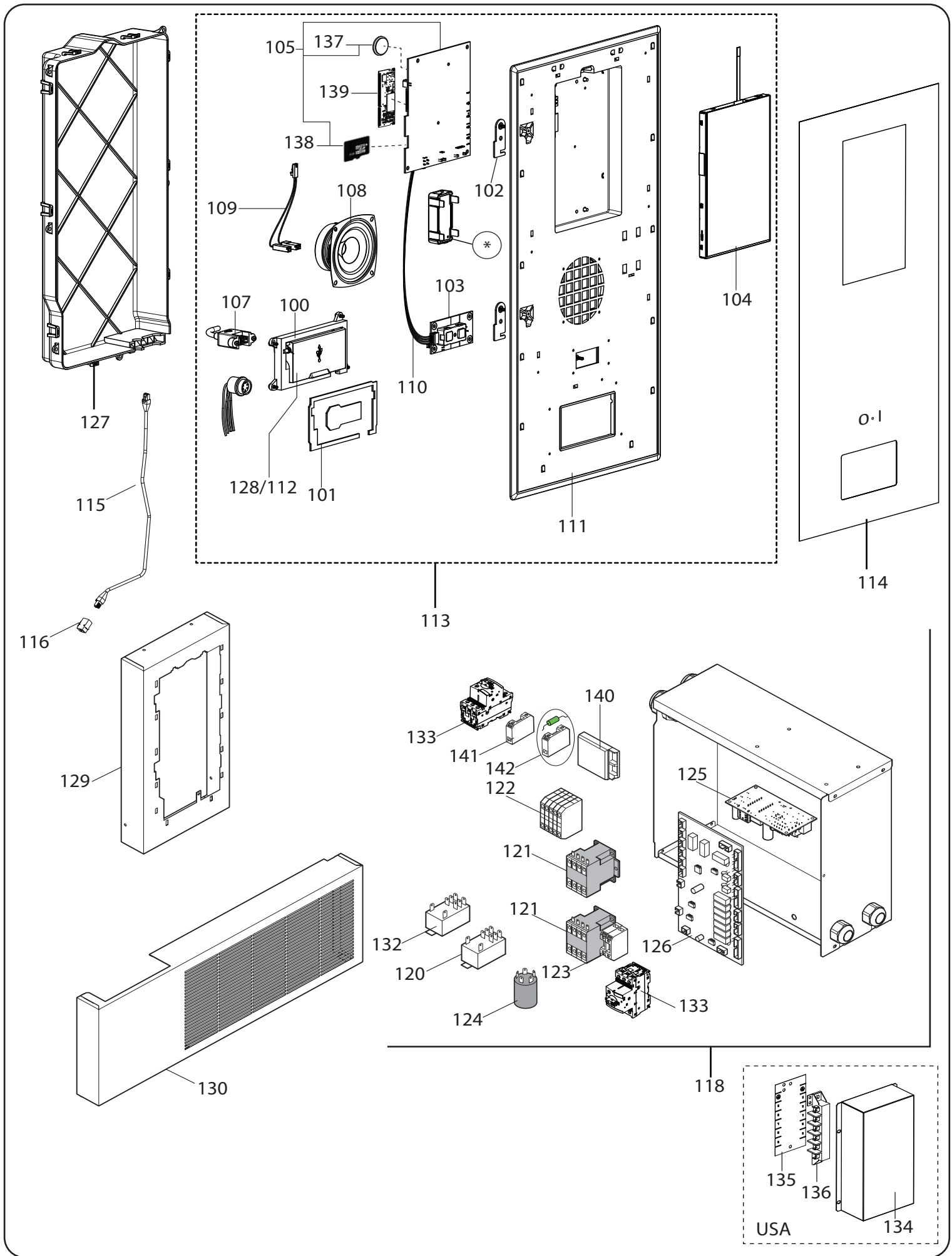

Pos	Code	Factory code	Description	Descrizione	Ref/notes
1	095982	0543R20101	ASSEMBLY COVER WITH MAGNET - V	CORNICE VERTICALE	up to week 44 2019 - 451 mm
1	096434	0543R24101	ASSEMBLY COVER WITH MAGNET - V	CORNICE VERTICALE (left and right)	from week 45 2019 - 451 mm
2	096065	0543R23600	ASSEMBLY COVER WITH MAGNET - H	CORNICE ORIZZONTALE SUP.	up to week 44 2019 - 775 mm
2	096433	0543R23800	ASSEMBLY COVER WITH MAGNET - H	CORNICE ORIZZONTALE SUP.	from week 45 2019 - 775 mm
3x	095918	0835R59603	DOOR FOAMED RIGHT ELUX BCF30	PORTA SCHIUMATA DX 30 kg	ELUX RIGHT
3	096582	0835R63701	DOOR FOAMED LEFT ELUX BCF30	PORTA SCHIUMATA SX 30 kg	ELUX LEFT
3a	096581	0882R15404	DOOR MOD DX ELUX	MODULO PORTA DESTRA	ELUX RIGHT
3b	096102	0882R44301	DOOR MOD DX ZAN/APX/TO BRAND	MODULO PORTA DESTRA	ZAN/APX/TO BRAND RIGHT
3c	096098	0882R11401	DOOR MOD SX ELUX	MODULO PORTA SINISTRA	ELUX LEFT
3d	096583	0882R44200	DOOR MOD SX ZAN/APX/TO BRAND	MODULO PORTA SINISTRA	ZAN/APX/TO BRAND LEFT
4	095927	0882R16200	TOP MODULE BCF30 JJ	TOP	
5	095926	0882R01200	KIT MOD FEET H150 BCF (With screws)	KIT PIEDINI CON VITI H150/200	a,b,d
5	096243	0883R09200	KIT MOD FEET H150 BCF (With screws)	KIT PIEDINI CON VITI H150/200 USA	c
5a	048579	0855631900	FEET H150/200	PIEDINO H150/200	a,b,d
5a	096236	0833R48700	FEET H150/200 USA	PIEDINO H150/200 USA	c
6	096458	0543R20500	ASSEMBLY COVER WITH MAGNET - V P	CORNICE VERTICALE PANNELLO SCH.	up to week 44 2019 - 449 mm
6	096441	0543R24800	ASSEMBLY COVER WITH MAGNET - V P	CORNICE VERTICALE PANNELLO SCH.	from week 45 2019 - 450 mm
7	096051	0505R28200	SIDE HINGE SUPPORT FOR H100	LATO CERNIERA SUPPORTO FORNO	
8	092917	0510789200	LOWER DOOR SUPPORT	PIASTRINA INF.PORTA	
9	081654	0544700601	LOWER DOOR BUSH	BOCCOLA X 1/2P INFERIORE	
10	095959	0505R26602	LEFT LOWER HINGE	CERNIERA INFERIORE SX	
11	099909	0835R03800	PLATE DOOR OPEN	ASS. DISP. BLOCCO PORTA APERTA	
12	095985	0548R13300	DOOR MAGNETIC GASKET BCF30	GUARNIZIONE PORTA	
13	083876	0835714501	UPPER HINGE DOOR	CERNIERA CON MOLLA PERNO RIB.	
14		0543R21700	ASSEMBLY COVER WITH MAGNET - H	CORNICE ORIZZONTALE INF. LUNGA	up to week 44 2019 - 547 mm
14		0543R23901	ASSEMBLY COVER WITH MAGNET - H	CORNICE ORIZZONTALE INF. LUNGA	from week 45 2019 - 547 mm
15	096064	0543R21600	ASSEMBLY COVER WITH MAGNET - H	CORNICE ORIZZONTALE INF. CORTA	up to week 44 2019 - 228 mm
15		0543R24000	ASSEMBLY COVER WITH MAGNET - H	CORNICE ORIZZONTALE INF. CORTA	from week 45 2019 - 228 mm
16	093935	0514R13301	FRONT RACK SUPPORT	SUPPORTO GUIDE ANT. BCF	
17	093936	0514R13401	BACK RACK SUPPORT	SUPPORTO GUIDE POST. BCF LW	
18	089970	0518713900	PIN FOR RACK	PERNO PER CARTER M6 BCF	
19		0833R50200	RACK SUPP. ASSEMBLY (LEFT) 15/10 up to unit week 27/2020	ASS. ASS. STRUTTURA 30KG SX 15/10 fino a unità prodotte in week 27/2020	Replace code 096036 - Upgrade sturdiness
20	093939	0530R04700	LOCK NUT FOR RACK	CHIAVETTA DI SERRAGGIO	
21	096450	0514R29400	SPRING FOR RACK	MOLLA BLOCCO CREMAGLIERE	
22		0833R50100	RACK SUPPORT ASSEMBLY (RIGHT) 15/10 without slide only holes /up to unit week 27/2020	ASS. STRUTTURA DX senza sede di scorrimento solo fori /fino a unità prodotte in week 27/2020	Replace code 095931 - Upgrade sturdiness
22a	096551	833R47001	RACK SUPPORT ASSEMBLY (left and right) 15/10	ASS. STRUTTURA DX & SX 15/10	Unit from Week 28 2020 not retrofit
23	096548	505R08L00	LEFT GUIDE FOR RACK 15/10	GUIDA BCF 30-50KG SX 15/10	Replace code 093862 - Upgrade sturdiness
24	096547	505R08K00	RIGHT GUIDE FOR RACK 15/10	GUIDA BCF 30-50KG DX 15/10	Replace code 093861 - Upgrade sturdiness
25	089977	0510774302	BASIN GUIDE	GUIDA PER BACINELLA EST	
26	096052	0505R28300	SUPPORT FOR BCF 30 TOWER H100	SUPPORTO PER FORNO	
27	080803	0242452410	BLACK CONDESATE BASIN	BACINELLA RACC.COND.NERO	
28	096053	0505R29500	UPPER HINGE DOOR	CERNIERA SUP.X ABB. SX	
29	095977	0518R09300	LOWER PIN FOR BCF JJ SRUCTURE	PERNO INFERIORE STRUTTURA	
30	093938	0546R29300	RACK SUPPORT	APPOGGIO PER CREMAGLIERE	
31	095960	0505R26702	RIGHT LOWER HINGE BCF30 JJ	CERNIERA INFERIORE DX	
32	096040	0503R50401	LEFT UPPER HINGE WITH STOPPER	CERNIERA SUPERIORE SX	
33	096056	0514R28000	STUD FOR DOOR STOP BCF JJ	PERNO PER FERMO PORTA SUP	
34	096102	0882R44301	DOOR LEFT ZAN/APX ASS.Y	ASS. PORTA SX APX/ZAN	APX/ZAN LEFT

Pos	Code	Factory code	Description	Descrizione	Ref/notes
35	097535	0546R08B00	DOOR GASKET PROTECTION	PROTEZIONE GUARNIZIONE PORTA	
36	096325	0835r72302	DISCHARGE PLUG DEVICE	ASS. TAPPO SCARICO CELLA JJ	
37	095966	0514R28700	LOCKING SPRING BCF JJ	MOLLA PE STRUTTURA SX	
38	096046	0503R94300	FRONT PANEL STAKING KIT BCF30	PANNELLO FRONTALE	
39	096047	0503R94400	LATERAL SIDE PANEL STAKING KIT	PANNELLO LATERALE	
40	096045	0503R94200	WATER DISCHARGE COLLECTOR	BACINELLA DI SCARICO FORNO	
41	096057	0515404U00	ELBOW DRAIN PIPE	CURVA DIA 50 90° - PP	
42	096035	0544402200	RIGHT DRAIN PIPE	TUBO DIA 50 L150 - PP	
43	096098	0882R11400	DOOR ELUX LEFT ASS.Y	ASS. PORTA SX	ELUX LEFT
44	096584	0835R69001	FOAMED DOOR LEFT ZAN/APX	ASS. PORTA SX	ZAN/APX LEFT
50	095913	0830R14201	FINNED COIL EVAPORAT. BCF 30 KG	EVAPORATORE	
51	095958	0505R13900	CARTER SUPPORT	STAFFA CARTER 30KG	
52	096042	0503R90402	CARTER FAN	CARTER VENTILATORI X BCF 30KG	a,b
52	097532	0504R17800	CARTER FAN	CARTER VENTILATORI X BCF 30KG	c,d
52	097529	0504R02301	CARTER FAN	CARTER VENTILATORI X BCF 30KG	c with UV lamp
53	082096	0639704600	HOSE CLAMP Hole 17.5 mm	PASSACAVO_ FORO 17.5mm	
54	096011	0682R11801	CAVITY FAN Ø350	VENTILATORE CELLA Ø350 EU	a,b
54	096333	0682R13000	CAVITY FAN Ø350 200/240 V 50/60 hz	VENTILATORE CELLA Ø350 usa+Row	c,d
55	095963	0514R26701	PROTECTION FAN_GRID DIAM.380	PROTEZ. VENTILATORE DIAM.380	a,b
55	096424	0514R29901	PROTEC. FAN_GRID DIAM.380 AISI	PROTEZ. VENTILATORE DIAM.380 AISI	c,d
56	095930	0856R35501	HEATING ELEMENT - EVAPORATOR	RESISTENZA EVAPORATORE 800W	a,b
56	096334	0856R36400	HEATING ELEMENT - EVAP. 208V 60HZ UL	RESISTENZA EVAP. 208V 800W UL	c
56	096588	0617R03J00	HEATING ELEMENT - EVAP. 230V 60HZ	RESISTENZA EVAP. 230V 800W Row	d
57	048429	0506675402	FIXING HEATING ELEMENT	SQUADR.FISS.RESIST.	
58	096062	0504R06001	FRONT AIRFLOW DIFFUSER	DIFFUSORE ARIA FRONTALE	
59	095955	0503R76203	REAR AIRFLOW DIFFUSER	DIFFUSORE ARIA POSTERIORE	
60	096003	0646R19002	CELL PROBE "BLUE"	SONDA 6X20 BLU 'CELL'	a,b
60	096335	0646R22400	CELL PROBE "BLUE" UL USA	SONDA 6X20 BLU 'CELL' UL USA	c
60	096335	0646R22400	CELL PROBE "BLUE" UL USA	SONDA 6X20 BLU 'CELL' UL USA	d up to 2022/28
60	096073	0646R21100	CELL PROBE BLUE long	SONDA 6X20 BLU 'CELL' lunga	d from 2022/29
61	096004	0646R19102	EVAPORATOR PROBE "GREY"	SONDA 6X40 EVAP	a,b,d
61	096336	0646R22500	EVAPORATOR PROBE "GREY" UL USA	SONDA 6X40 EVAP UL USA	c
62	095990	0617R18301	HEATING ELEMENT CABLE L=3165MM	RESISTENZA CORNICE PORTA	a,b,d
62	096337	0617R18600	HEATING ELEMENT CABLE L=3165MM	RESISTENZA CORNICE PORTA UL	c
63	091800	0639730101	HOOK FRO MEET PROBE	GANCIO IN AISI 304	
64	096007	0646R19402	MEET PROBE 3 SENSOR	SPELLONE CONICO 3 PUNTI	a,b,d
64	096338	0646R22801	MEET PROBE 3 SENSOR UL usa	SPELLONE CONICO 3 PUNTI UL	c
65	088473	0684723501	COMP. DORIN H181CS	COMP. DORIN H181CS	a
65	096237	0684R13900	COMP DORIN H181CCK//UL 208-230/360-400/3/60 CB	COMP DORIN H181CCK//UL 208-230/360-400/3/60 CB	c,d
66	094955	0511R01900	CONDENSER FAN	VENTOLA ASPIRANTE ALLUM. 254X31	a,c,d
67	096012	0682R12401	CONDENSER MOTOR FAN	VENTILATORE 230-240V/50-60 HZ	a,d
67	096459	0805R00F00	CONDENSER MOTOR FAN USA UL	VENTILATORE 208-60 HZ UL	c
68	095912	0830R14103	FINNED COIL CONDENSER	CONDENSATORE	a,c,d
69	095948	0503R49303	CONDENSER CONVEYOR	CONVOGLIATORE CONDENSATORE	a,d
69	096238	0504R12500	CONDENSER CONVEYOR usa	CONVOGLIATORE CONDENSATORE	c
70	088201	0646725601	FILTRO GAS DML052	FILTRO DCL083S 10MM	a,c,d
71	088030	0646746400	EVR 6 BODY SOLENOID VALVE	CORPO VALV. EVR 6	a,d
72	085847	0646729100	EVR 6 COIL SOLENOID VALVE	BOB.CLIP ZB15 PARKER EVR6	a,d
72	095063	0646R14000	EVR 6 COIL SOLENOID VALVE	BOB.CLIP ZH14 PARKER (304104) 220-230V 50/60HZ 14W IP65 CL.H	a,d - Peer to peer
73	087758	0805749401	TANIC RECEIVER	RICEVITORE DI LIQ. A SALD. 0,88 L	a,c,d
74	088475	0646754601	EXPANSION VALVE R452/404A/448a	TUBE,RANGE NL,-40/-15,MOP-10 OR.6	a,b,c,d

Pos	Code	Factory code	Description	Descrizione	Ref/notes
75	095939	011008R010	INSULATION FOR THERMOS. VALVE	ISOLAMENTO VALVOLA TERMOSTAT.	Diam. 15
75	095938	0110067003	INSULATION FOR THERMOS. VALVE	ISOLAMENTO VALVOLA TERMOSTAT.	Diam. 35
<b>76</b>	<b>097537</b>	<b>0832R28500</b>	<b>ASS. UV LAMP</b>	<b>ASSIEME LAMPADA</b>	<b>c with UV lamp</b>
77a	096002	0640R04101	DOOR MICRO SWITCH	MICROINTERRUTTORE PORTA	
<b>77b</b>	<b>095929</b>	<b>0646R20601</b>	<b>MAGNETIC SENSOR UV LAMP</b>	<b>SENSORE MAGNETICO LAMPADA UV</b>	<b>a UV lamp</b>
<b>77c</b>	<b>087533</b>	<b>0640712000</b>	<b>MAGNET STEM</b>	<b>MAGNETE STEM</b>	<b>a,c UV lamp from 2022/29</b>
78	096005	0646R19201	SUCTION PROBE "GREEN"	SONDA ASPIRAZIONE VERDE	a,b,d
78	096339	0646R22600	SUCTION PROBE "GREEN" UL USA +Row	SONDA ASPIRAZIONE VERDE	c
79	096006	0646R19301	CONDENSER PROBE "BLACK"	SONDA CONDENSATORE NERA	
80	096041	0503R73502	SUPPORT FOR MICROINT. STEM E511	SUPPORTO MICRO PORTA	Up to 2022/28
<b>80</b>	<b>097528</b>	<b>0503R73503</b>	<b>SUPPORT FOR MICROINT. STEM E511</b>	<b>SUPPORTO MICRO PORTA</b>	<b>From 2022/29</b>
81	094256	0546R26200	RUBBER SUPPORT	PORTAGOMMA	
82	094257	0546R26900	NUT 1"1/2	GHIERA 1"1/2	
83	095917	0835R59205	FOAMED PANEL BCF 30 JJ	PANNELLO SCHIUMATO	
84	096034	0525710600	SERVICE VALVE PIPE	TUBO CON VALVOLA DI RICARICA	
85	095964	0514R26804	REAR PROTECTIVE GRID BCF50 JJ	GRIGLIA POSTERIORE	a,b
85	096239	0514R30300	REAR PROTECTIVE GRID BCF50 JJ	GRIGLIA POSTERIORE	c,d
86	095961	0505R29302	SPACER PROTECTION	DISTANZIALE POSTERIORE BCF LW	a,b
86	096240	0505R30900	SPACER PROTECTION	DISTANZIALE POSTERIORE BCF LW	c,d
87	096068	0639R19700	ELECTRICAL BOX CONNECTION REM.	SCATOLA GEWISS GW44276 IP56	b
88	096071	0639R20000	CLAMP TO CONNECTION REM	MORSETTIERA SCATOLA REMOTA JJ	b
89	096325	0835r72302	DISCHARGE PLUG DEVICE	ASS. TAPPO SCARICO CELLA JJ	
90	096340	0652R02800	SAFETY THERMOSTAT +93°C	TERMOFUSIBILE 93° C UL	
91	087960	0646750300	EVR 6 BODY SOLENOID VALVE	CORPO VALVOLA EVR3- UL-CSA	c
92	096423	0856R38101	EVR 6 COIL SOLENOID VALVE EL V1	BOBINA PER VALVOLA SOLEN.	c, White connector
93	099869	0646765300	SAFETY PLUG UL USA	TAPPO FUSIBILE UL 1/8"	c
94	096241	0830R02A01	EVR 6 COIL SOLENOID VALVE EL V2	BOBINA PER VALVOLA SOLEN.	c, Red connector
*	096171	0147300900	AMERICAN CANVAS TAPE M50XMM48	NASTRO TELA PLAST. M50XMM48	
*	095768	0147017034	PIVILENE INSULATION TAPE; 50X3SP	NASTRO 3M389 NERO (MM19 X 50MT)	
<b>95</b>	<b>084384</b>	<b>0624705200</b>	<b>PLASTIC SPRING</b>	<b>MOLLE PE LAMPADA</b>	<b>c with UV lamp</b>
<b>96</b>	<b>093097</b>	<b>0549R05400</b>	<b>GLASS UV</b>	<b>VETRO FRONTALE LAMPADA</b>	<b>c with UV lamp</b>
<b>97</b>	<b>093946</b>	<b>0559R01800</b>	<b>FRONT GASKET</b>	<b>GUARNIZIONE LAMPADA</b>	<b>c with UV lamp</b>
<b>98</b>	<b>093948</b>	<b>0665R01100</b>	<b>UV SUPPORT</b>	<b>SUPPORTO LAMPADA</b>	<b>c with UV lamp</b>
<b>99</b>	<b>093949</b>	<b>0661R01100</b>	<b>UV LAMP</b>	<b>LAMPADA</b>	<b>c with UV lamp</b>
100	0CK030	0546400U01	DRAWER USB SUPPORT	CKM SEDE USB	
101	0CK031	0543401P02	GASKET DRAWER USB SUPPORT	GUARNIZIONE SEDE USB	
102	0CK432	0506405M00	PANEL HOOK	GANCIO PANNELLO	
103	0CK033	0675401G00	ON/OFF BOARD	SCHEDA ON/OFF	
104	0CK034	0673400900	DISPLAY JDI 7"	DISPLAY JDI 7" TP RESISTIVO	
105	0CK036	0675401J01	BRIDGE BOARD	SCHEDA CONNESSIONE DISPLAY	
*	0CK674	675403M00	MICROSD HC 8GB CL4 SANDISK	MICROSD HC 8GB CL4 SANDISK	
107	0C9603	0638F00800	WIRING USB	CAVO USB	
108	0CK039	0655400000	SPEAKER VISATON	ALTOPARLANTE	
109	0CK330	0675401L00	WIRING SPEAKER	CAVETTO CONNESSIONE SPEAKER	
110	0CK045	0675401Q00	WIRING ON/OFF BOARD	CAVETTO ON-OFF TOUCH	
111	0CK040	0543401N01	PLASTIC FRAME TOUCH	PANNELLO IN PLASTICA	
112	0CK041	0546400V01	USB COVER	SPORTELLO USB ELUX	
113	0CK685	083040PL01	ASS. TOUCH UI ELUX WITH ETHERNET DIRECT CONNECTION	PANNELLO COMPLETO UI CON CONNESSIONE ETHERNET	only to peer to peer
113	0CK661	083040PG01	ASS. TOUCH UI ELUX	PANNELLO COMPLETO UI	all others units
114	095934	0755R13902	ADHESIVE DECOR A ELUX TOUCH	MEMBRANA ADESIVE ELUX	order also N° 111
114	095935	0755R16103	ADHESIVE DECOR A ZAN TOUCH	MEMBRANA ADESIVE ZAN	order also N° 111

Pos	Code	Factory code	Description	Descrizione	Ref/notes
114	096058	0541401V02	ADHESIVE DECOR TO BRAND	MEMBRANA ADESIVE TO BRAND	order also N° 111
114	095936	0755R16202	ADHESIVE DECOR ALPEN	MEMBRANA ADESIVE APX	order also N° 111
115	0CB910	0638406L00	CAVO ETHERNET RJ45 M-M CAT.5E SCHEMATO L=1000MM	ETHERNET CABLE RJ45 M-M CAT.5E L=1000MM	
116	0CB911	0639402900	GIUNTO RJ45 - VS-08-BU-RJ45/BU - PHOENIX 1689064	CONNECTION RJ45 - VS-08-BU-RJ45/BU - PHOENIX 1689064	
118	096078	0882R15204	ELECTRICAL BOX COMPLETE	SCATOLA ELETTRICA COMPLETA	a, for EU cooling on board
118	096081	0882R72002	ELECTRICAL BOX COMPLETE	SCATOLA ELETTRICA COMPLETA	b, for EU predis. remote C.
118	096575	0883R10902	ELECTRICAL BOX COMPLETE	SCATOLA ELETTRICA COMPLETA	c, for USA cooling on board
<b>118</b>	<b>097540</b>	<b>0883R72000</b>	<b>ELECTRICAL BOX COMPLETE</b>	<b>SCATOLA ELETTRICA COMPLETA</b>	<b>c, for USA UV Lamp cooling on board</b>
118		0883R28100	ELECTRICAL BOX COMPLETE	SCATOLA ELETTRICA COMPLETA	d, for ROW cooling on board
118		0883R41600	ELECTRICAL BOX COMPLETE	SCATOLA ELETTRICA COMPLETA	a, for peer to peer prod.
120	093848	0648R06300	RELAY	RELE' FINDER	
121	088477	0648807300	CONTACTOR	CONTATTORE K3-10N 230V 50/60HZ	a,d
121	099090	0648729200	CONTACTOR (COIL 200-240/60)	CONTATTORE K3-10N (COIL 200-240/60)	c
122	096067	0639R18001	MAIN TERMINAL BLOCK	BLOCCHETTI DI CONNESSIONE ELET.	a,d
122	096341	0639R22500	MAIN TERMINAL BLOCK UL	BLOCCHETTI DI CONNESSIONE ELET.	c
123	095933	0652R02400	GLASS FUSE 10A T 5X20	FUSIBILE IN VETRO 10A T 5X20	a,b
123	0L3083	0652608900	CERAMIC FUSE 10A T 5X20	FUSIBILE CERAMICO 10A T 5X20	c,d
124	084987	0694700800	FILTRO PROCOND	FILTRO R.F.I.	
124	059078	0694502400	FILTRO LC	FILTRO LC	Peer to peer
125	095639	0648R10000	POWER SUPPLY 12V 30W	SCHEDA DI POTENZA 12V 30W	a,b,d
125	096342	0648R11400	POWER SUPPLY 12V/100W UL	SCHEDA DI POTENZA 12V/100W UL	c
126	096010	0648R08602	ACU PETRA BCF	SCHEDA PRINCIPALE PETRA	up to 2020/20 canceled
<b>126</b>	<b>096557</b>	<b>0648R10900</b>	<b>ACU PETRA BCF - BITRON</b>	<b>SCHEDA PRINCIPALE PETRA-BITRON</b>	<b>from 2020/21</b>
127	0CK161	0541401D01	PROTECTION COMAND PANEL	PROTEZIONE PANNELLO COMANDI	
128	0CK032	0514405001	SPRING FOR DRAWER USB	MOLLA PER SPORTELLINO	
129	095946	0503R48403	CONTROL PANEL BCF30 JJ	PANNELLO DI CONTROLLO	
130	095950	0503R55503	CONDENSER PANEL BCF30 JJ ELUX	PANNELLO CONDENSATORE	ELUX
130	096043	0503R91001	CONDENSER PANEL BCF30 ZAN/APX/	PANNELLO CONDENSATORE	ZAN/APX TO BRAND
132	006610	0648806900	RELE'62.838.230.0009+ATT.BARRA DIN	RELE' CONNESSIONE REMOTA	b
133	091707	0640R00700	SAFETY PROTECTION MOTOR	SALVAMOT. ABB MS116-16 (10...16A)	c
134	096443	0505R31400	TERMINAL BLOCK COVER	COPERTURA MORSETTIERA	c
<b>135</b>	<b>097526</b>	<b>0598610500</b>	<b>TERMINAL BLOCK PLATE</b>	<b>TARGHETTA MORSETTIERA 6 POLI</b>	<b>c</b>
136	088165	0639726600	TERMINAL BLOCK	MORSETTIERA	c
137			BATTERY CR2032 V3 LITIO	BATTERIA MODELLO CR 2032 V3 LITIO	
138			MICRO SD 4G 4HC	MICRO SD 4G 4HC	
139	0CK035	0675401H00	CORE BOARD DAVE	TOUCH	
<b>140</b>	<b>097536</b>	<b>0624R00J00</b>	<b>POWER VOLTAGE ADAPTOR UV BULB</b>	<b>ALIMENTATORE UV LAMPADA</b>	<b>c for UV lamp</b>
<b>141</b>	<b>091725</b>	<b>0640R01000</b>	<b>AUXSILIARY SWICTH PROT. OVER CU.</b>	<b>CONTATTI AUSILIARI HK1-11 SALVA.</b>	<b>c</b>
<b>142</b>		<b>0835R33T00</b>	<b>KIT UV LAMP RECOVERY</b>	<b>KIT UV LAMP RECOVERY</b>	<b>UV lamp from 2022/29 - See Tech. Sheet VTX2022_02</b>

BLAST CHILLER FREEZER  
KIT DI MANUTENZIONE – MAINTENANCE KIT

CHILL<sup>S</sup> 30 KG

Spare Part Code KIT	Description KIT	Spare Part Code	Spare Part Q.ty	Spare part Description	Descrizione Spare part	Ref./ Note
<b>KIT DI MANUTENZIONE - MAINTENANCE KIT</b>						
<b>096166</b>	<b>SKL BCF 30 PM KIT</b>					
		095985	1	DOOR MAGNETIC GASKET BCF30	GUARNIZIONE PORTA	
		095939	2mt	INSULATION FOR THERMOS. VALVE	ISOLAMENTO VALVOLA TERMOSTAT.	Diam. 15
		095938	2mt	INSULATION FOR THERMOS. VALVE	ISOLAMENTO VALVOLA TERMOSTAT.	Diam. 35
		095989	1mt	COIBENTATION PIPES	TUBO ANTICOND. GREY DIAM.16-36	
		095165	1	CLIP OBO 255/3,2 OBO 255.3.2	FERMACAVO OBO 255/3,2 OBO 255.3.2	
		096156	3	SCREW 4,8X70/60 DIN 6928	VITE AUTOFIL. TE FLANG. ZINCATA 4,8X70/60 DIN 6928	

Electrolux Professional SpA  
Viale Treviso, 15  
33170 Pordenone, ITALY  
Fax (+39) 0434 380 201  
<https://www.electroluxprofessional.com>  
<https://webgate.electroluxprofessional.com>