

**BLAST CHILLER- FREEZER
ABBATTITORI CONGELATORI**

SKCH 10GN 1_1

Type Reference	Ref	Page	Description	note
SKCH50B	a	3_4_6_9	BCF 50KG 380V BUILT IN 50 HZ	
SKCH50R	b	3_4_7_9	BCF 50KG 380V REMOTO 50/60HZ	

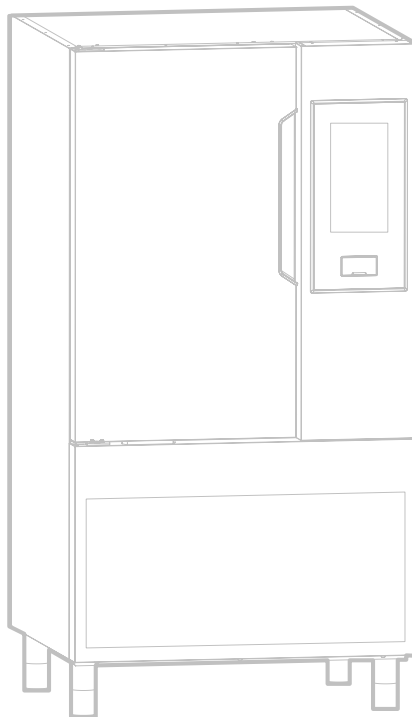

Index

Descriptions type ref/Descrizione el Type refence	2
Exploded view internal components/ Vista esplosa componenti interni	3
Exploded view Doors/ Vista esplosa porte	4
Spare part list/Lista ricambi	5
Exploded view cooling unit/ Vista esplosa gruppo refrigerante	6
Exploded view cooling unit remote/ Vista esplosa gruppo refrigerante remoto	7
Spare part list/Lista ricambi	8-9
Control panel/pannello comandi	10
Spare part list/Lista ricambi	11
Maintenance kit/Kit di manutenzione	12

...**Bold**= last change/Grassetto =ultima modifica

V = Vital spare part/Ricambio vitale

W&T = Wear&Tear and Consumable/Ricambio usurabile e consumabile

S = Suggested/Ricambio suggerito

Bold=last change / Grassetto =ultima modifica

Rev. 2

How to put in relation the “Type Ref.” reported on the data plate with the “Type reference” reported on the front page of the Spare Part Catalogue:

The “Type Ref.” represents a group of models/brands all with similar technical features, hence possible to be reported under the same scheme in terms of exploded views.

Electrolux

SKCH

- B= UNIT ON BOARD CONDENSING UNIT
- R= REMOTE CONDENSING UNIT
- 30 = range 30 kg
- 50 = range 50 kg
- 70 = range 70 kg
- 100 = range 100 kg
- 150 = range 150 kg
- 200 = range 200 kg
- SKCH = SKYLINE CHILLER\FREEZER (EUROPA\SAUDI ARABIA\KOREA)
- SKCHU = SKYLINE CHILLER\FREEZER (NORD AMERICA)

ES : **SKCH30B** = range 30 kg gn 1\1 with cooling unit (europa etc.)
SKCH30R = range 30 kg gn 1\1 without cooling unit (remote) (europa etc.)
SKCHU30B = range 30 kg gn 1\1 with cooling unit (nord America)
SKCHU30R = range 30 kg gn 1\1 without cooling unit (remote) (nord America)

Find below an identification example: SKCH30B

F.Mod. PNC 9VTX.....	Comm.Model Ser.Nr.....	Type Ref. SKCH30B	2019
W.Tot. kW	Volt..... Hz.....	Cyclopentane	Total Current A
Evaporation Heater El. kW	Class x	GWP	CO2-eq t
Lighting W	Cap. Refrigerant	Kg	
Defrost Power kW	Heating power kW		
NF nominal Charge			
Rated Pressure Mpa		CE	REE
IPX4			
Electrolux Professional SPA - Viale Treviso, 15 - 33170 Pordenone (Italy)			

For the right spare code identification follow the steps:

- 1.Type in the website the PNC reported on the data plate.
- 2.The website will automatically display this spare part catalogue.
- 3.The spare part code at this point is referenced through the “Type reference” as from the front page by the relevant “Ref”.

Come mettere in relazione il “Type Ref.” Riportato sulla targhetta caratteristica con il “Type reference” riportato sul frontespizio del catalogo ricambi:

Il “Type Ref.” Rappresenta un gruppo di modelli/marchi con simili caratteristiche tecniche, ossia possibili da rappresentare con il medesimo schema in termini di vista esplosa.

Electrolux

SKCH

- B= UNITA' CON GRUPPO
- R= UNITA' PREDISPOSTA REMOTA
- 30 = MODELLO 30 kg
- 50 = MODELLO 50 kg
- 70 = MODELLO 70 kg
- 100 = MODELLO 100 kg
- 150 = MODELLO 150 kg
- 200 = MODELLO 200 kg
- SKCH = SKYLINE CHILLER\FREEZER (EUROPA\SAUDI ARABIA\KOREA)
- SKCHU = SKYLINE CHILLER\FREEZER (NORD AMERICA)

ES : **SKCH30B** = range 30 kg gn 1\1 con gruppo (europa etc.)
SKCH30R = range 30 kg gn 1\1 predisposto remoto (europa etc.)
SKCHU30B = range 30 kg gn 1\1 con gruppo (nord America)
SKCHU30R = range 30 kg gn 1\1 predisposto remoto (remote) (nord America)

Qui di seguito un esempio di identificazione: SKCH30B

F.Mod. PNC 9VTX.....	Comm.Model Ser.Nr.....	Type Ref. SKCH30B	2019
W.Tot. kW	Volt..... Hz.....	Cyclopentane	Total Current A
Evaporation Heater El. kW	Class x	GWP	CO2-eq t
Lighting W	Cap. Refrigerant	Kg	
Defrost Power kW	Heating power kW		
NF nominal Charge			
Rated Pressure Mpa		CE	REE
IPX4			
Electrolux Professional SPA - Viale Treviso, 15 - 33170 Pordenone (Italy)			

Per identificare il corretto codice ricambio procedere con:

- 1.Digitare nel website il PNC riportato sulla targhetta caratteristica.
- 2.Il website mostrerà automaticamente questo catalogo ricambi.
- 3.A questo punto, il codice ricambio è identificabile attraverso il “Type reference” come indicato nel frontespizio sotto la relativa voce “Ref”.

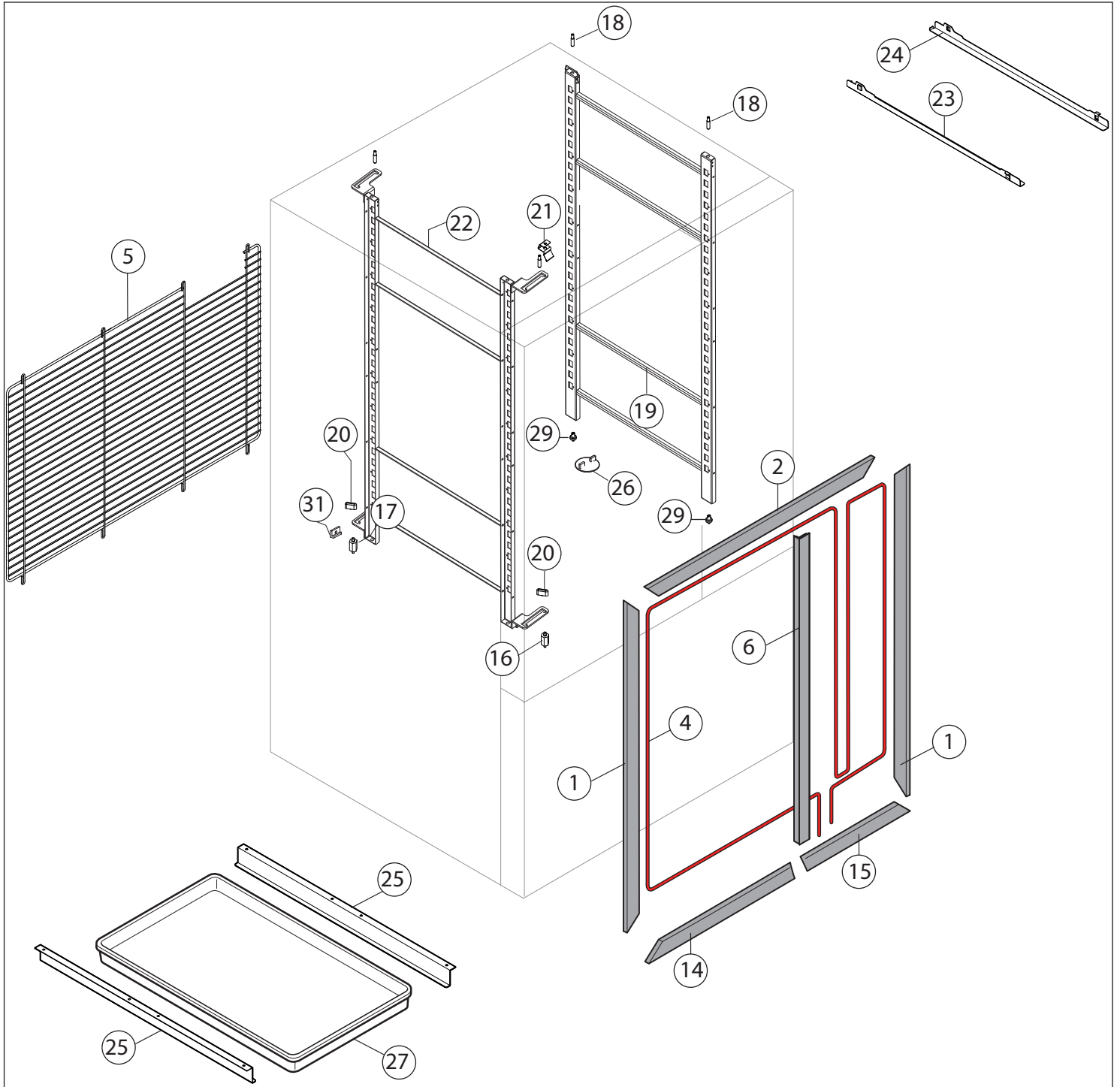

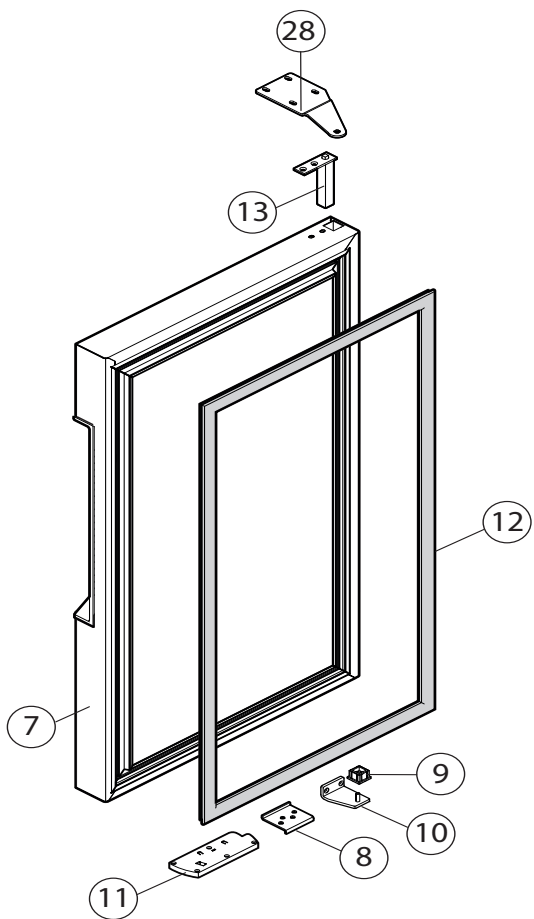

DOOR ELUX LEFT

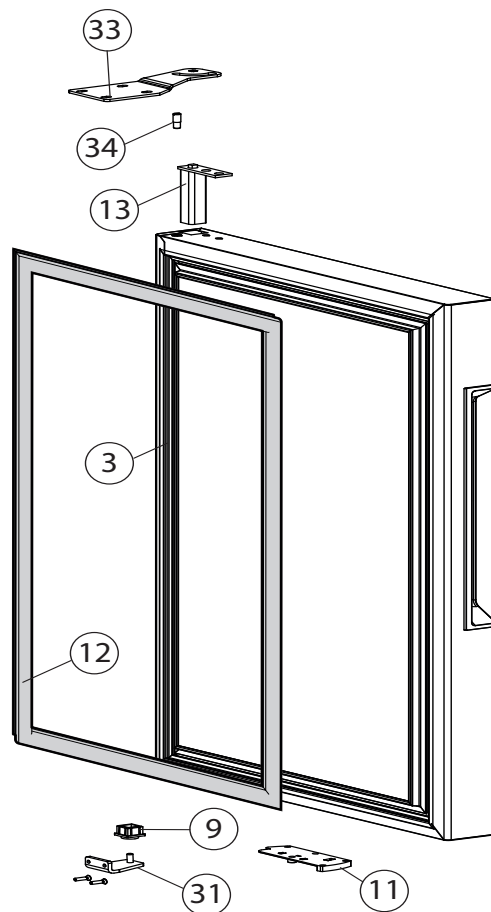

DOOR ELUX RIGHT

DOOR apx/zan LEFT

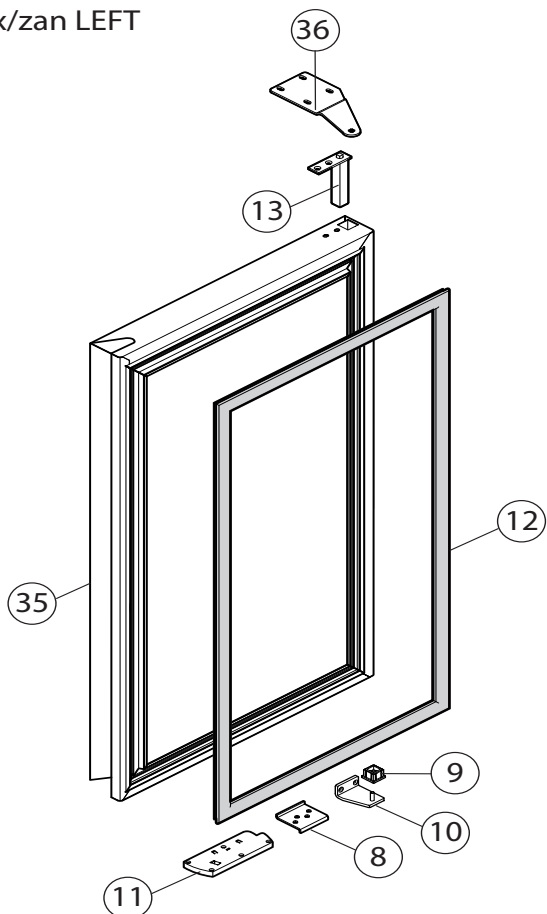

Pos	Code	Factory code	Description	Descrizione	V	W & T	S	Ref/notes
Reference pag.3-4								
1	095981	0543R17101	ASSEMBLY COVER WITH MAGNET - V	CORNICE VERTICALE				
2	096065	0543R23600	ASSEMBLY COVER WITH MAGNET - H	CORNICE ORIZZONTALE SUP.				
3	096097	0882R09400	DOOR RIGHT ELUX ASS.Y	ASS. PORTA DX				ELUX RIGHT
4	095991	0617R18401	HEATING ELEMENT CABLE L=4510MM	CAVO RISCALDANTE				
5	095962	0514R26601	REAR PROTECTIVE GRID BCF50 JJ	GRIGLIA POSTERIORE				
6		0543R18700	ASSEMBLY COVER WITH MAGNET - V P	CORNICE VERTICALE PANNELLO SCH.				
7	095915	0835R51002	DOOR FOAMED LEFT ELUX BCF50	PORTA SCHIUMATA SX				
8	092917	0510789200	LOWER DOOR SUPPORT	PIASTRINA INF.PORTA				
9	0A8856	0544705201	LOWER DOOR BUSH	BOCCOLA X 1/2P INFERIORE	X			
10	095959	0505R26602	LEFT LOWER HINGE	CERNIERA INFERIORE SX				
11	099909	0835R03800	PLATE DOOR OPEN	ASS. DISP. BLOCCO PORTA APERTA				
12	095986	0548R13400	DOOR MAGNETIC GASKET BCF50	GUARNIZIONE PORTA	X	X		
13	083876	0835714501	UPPER HINGE DOOR	CERNIERA CON MOLLA PERNO RIB.	X	X		
14	096061	0543R21400	ASSEMBLY COVER WITH MAGNET - H	CORNICE ORIZZONTALE INF. SX				
15	096063	0543R21500	ASSEMBLY COVER WITH MAGNET - H	CORNICE ORIZZONTALE INF. DX				
16	093935	0514R13301	FRONT RACK SUPPORT	SUPPORTO GUIDE ANT. BCF				
17	093936	0514R13401	BACK RACK SUPPORT	SUPPORTO GUIDE POST. BCF LW				
18	089970	0518713900	PIN FOR RACK	PERNO PER CARTER M6 BCF				
19	096037	0833R47300	GRID ASSEMBLY	ASS. CREMAGLIERA 50KG LW				
20	093939	0530R04700	LOCK NUT FOR RACK	CHIAVETTA DI SERRAGGIO		X		
21	093962	0514R16300	SPRING FOR RACK	MOLLA BLOCCO CREMAGLIERE		X		
22	095932	0833R47200	GRID ASSEMBLY	CREMAGLIERA				
23	093862	0501R67301	LEFT GUIDE FOR RACK	GUIDA BCF 30-50KG SX				
24	093861	0501R67401	RIGHT GUIDE FOR RACK	GUIDA BCF 30-50KG DX				
25	089977	0510774302	BASIN GUIDE	GUIDA PER BACINELLA EST				
26	093934	0546R27300	PLUG	TAPPO FONDO BCF	X	X		
27	080803	0242452410	BLACK CONDESATE BASIN	BACINELLA RACC.COND.NERO		X		
28	088645	0506781700	UPPER HINGE DOOR	CERNIERA SUP.X ABB. SX				
29	095977	0518R09300	LOWER PIN FOR BCF JJ SRUCTURE	PERNO INFERIORE STRUTTURA				
30	095966	0514R28700	LOCKING SPRING	MOLLA DI BLOCCAGGIO CREM.RA				
31	093938	0546R29300	RACK SUPPORT	APPOGGIO PER CREMAGLIERE		X		
32	095960	0505R26702	RIGHT LOWER HINGE BCF30 JJ	CERNIERA INFERIORE DX				
33	096039	0503R50300	RIGHT UPPER HINGE WITH STOP	CERNIERA SUPERIORE DX				
34	096056	0514R28000	STUD FOR DOOR STOP BCF JJ	PERNO PER FERMO PORTA SUP				
35	096101	0882R44001	DOOR SX ZAN/APX ASS.Y	ASS. PORTA SX APX/ZAN				APX/ZAN LEFT
36	096054	0505R29600	UPPER HINGE DOOR	CERNIERA SUP.X ABB. SX				APX/ZAN LEFT

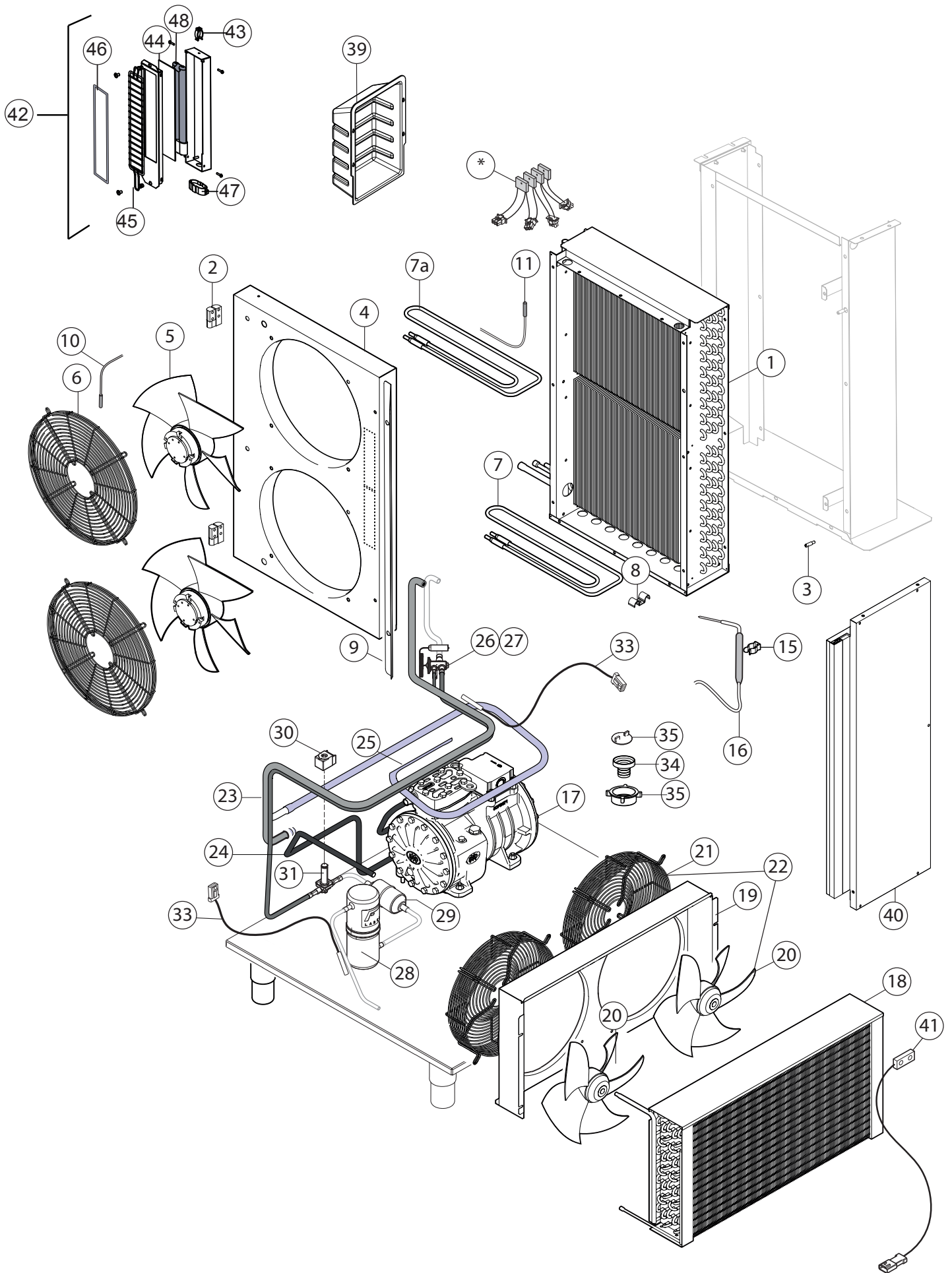

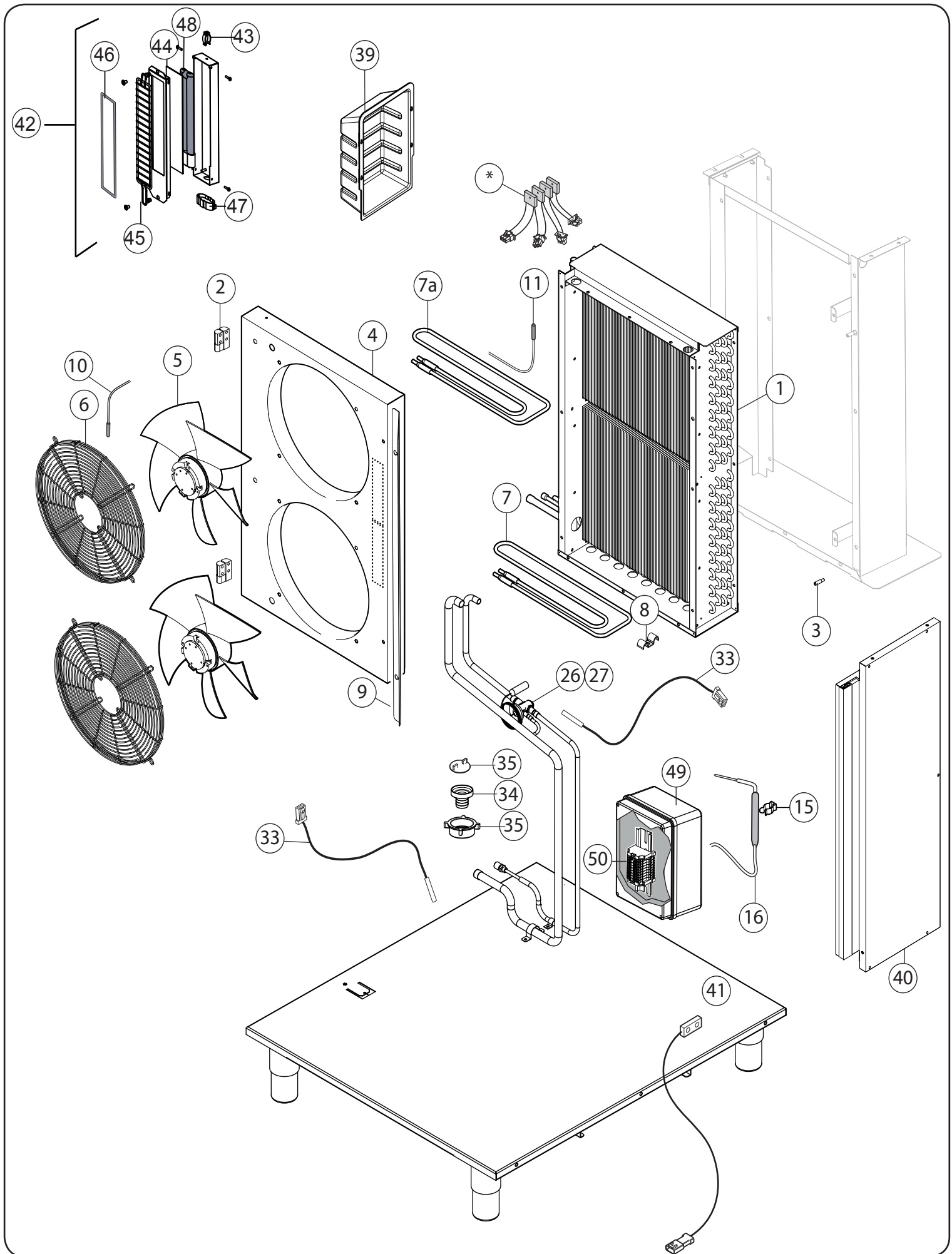

Pos	Code	Factory code	Description	Descrizione	V	W & T	S	Ref/notes
reference pag. 6-7								
1	096016	0830R12502	FINNED COIL EVAPORATOR BCF50	EVAPORATORE	X			
2	095979	0530R08100	CARTER HINGE	CERNIERA CARTER VENTILATORI				
3	089970	0518713900	PIN FOR CARTER FAN	PERNO PER CARTER M6				
4	095945	0503R37202	EVAP. CONVEYOR BCF50	CONVOGLIATORE EVAPORATORE				without predisp. for UV
4	096048	0504R02500	EVAP. CONVEYOR BCF50 UV LAP	CONVOGLI. EVAPORATORE UV LAP				predisposed for uv lamp
5	096011	0682R11801	FAN A3G350AN	VENTILATORE CELLA	X			
6	095963	0514R26701	GRID DIAM.380	GRIGLIA VENTILATORE CELLA				
7	096029	0856R31202	HEATING ELEMENT DOWN	RESISTENZA SBRINAMENTO BASSA	X	X		
7a	095923	0856R31402	HEATING ELEMENT UP	RESISTENZA SBRINAMENTO ALTA	X	X		
8	048429	0506675402	BRACKET FOR HEATING ELEMENT	SQUADR.FISS.RESIST.VASCA				
9	095940	0501R89200	FRONT DEFLECTOR	DEFLETTORE ANT				
10	096073	0646R21100	CELL PROBE BLUE	SONDA 6X20 BLU 'CELL'	X	X		
11	096074	0646R21200	EVAPORATOR PROBE GREY	SONDA 6X40 GRIGIA 'EVAP'		X		
15	091800	0639730101	FOOD PROBE HOOK	GANCIO IN AISI 304				
16	096072	0646R20700	FOOD PROBE	SPILLONE CONICO 3 PUNTI SILIC.		X		
17	096013	0684R12300	COMPRESSOR DORIN H281CS	COMPRESSORE H281 CS	X			a
18	096015	0830R12402	FINNED COIL CONDENSER BCF50	CONDENSATORE ARIA	X			a
19	095942	0503R10002	CONVEYOR AIR CONDENSER	CONVOGLIATORE CONDENS. 50KG				a
20	095895	0682R11600	FAN CONDENSER	VENTILATORE CONDENSATORE	X			a
21	092853	0514R09700	GRID FAN CONDENSER	GRIGLIA VENTILATORE CONDENSAT.				a
22	095924	0856R32200	ASS. FAN + GRID	ASS.VENTILATORE + GRIGLIA				a
23	095967	0515R33102	WELDED EXCHANGER BCF50	SCAMBIATORE SALDATO				a
24	095969	0515R33800	PIPE COMPRES.-CONDENSER BCF50	TUBO DA COMPRES. CONDENS.RE				a
25	095970	0515R33900	PIPE COMPRESSOR SUCTION BCF50	TUBO DA EVAP. A COMPRESSORE				a
26	088347	0646754900	EXPANSION VALVE -40/-15 ORIF.8	VALVOLA TERMOSTATICA	X			
27	095939	011008R010	INSULATION FOR THERMOS. VALVE	ISOLAMENTO VALVOLA TERMOSTAT.		X		Diam. 15
27	095938	0110067003	INSULATION FOR THERMOS. VALVE	ISOLAMENTO VALVOLA TERMOSTAT.		X		Diam. 35
28	087758	0805749401	TANIC RECEIVER	RICEVITORE DI LIQ. A SALD. 0,88 L				a
29	087438	0805747600	DEHIDRATOR FILTER	FILTRO DCL083S 10MM	X	X		a
30	088351	0646749000	BOB.CLIP 10W EVR6 220-230/50-60	BOBINA VALVOLA SOLENOIDE	X	X		a
31	084085	0646723000	BODY SOLENOID VALVE	CORPO VALV. EVR 6	X	X		a
32	096005	0646R19201	SUCTION PROBE "GREEN"	SONDA ASPIRAZIONE VERDE	X	X		
33	096006	0646R19301	CONDENSER PROBE "BLACK"	SONDA CONDENSATORE NERA	X	X		
34	094256	0546R26200	RUBBER SUPPORT	PORTAGOMMA		X		
35	094257	0546R26900	NUT 1'1/2	GHIERA 1'1/2		X		
39	095961	0505R29301	BACK SPACER PROTECTION	DISTANZIALE /COPERTURA POST.		X		
40	095916	0835R54903	EVAPORATOR FOAMED PANEL BCF50	PANNELLO SCHIUMATO DI COPERT.				
41	092319	0640R01402	DOOR MICROSWITCH	MICRO PORTA	X			
42	096075	0832R09501	ASS. UV LAMP	ASSIME LAMPADA				
43	084384	0624705200	PLASTIC SPRING	MOLLE PE LAMPADA				
44	093097	0549R05400	GLASS UV	VETRO FRONTALE LAMPADA				
45	093945	0514R11900	PROTECTION	PROTEZIONE				
46	093946	0559R01800	FRONT GASKET	GUARNIZIONE LAMPADA				
47	093948	0665R01100	UV SUPPORT	SUPPORTO LAMPADA				
48	093949	0661R01100	UV LAMP	LAMPADA				
49	096068	0639R19700	GEWISS BOX REMOTE	SCATOLA GEWISS REMOTO				b
50	096071	0639R20000	REMOTE CLAMP CONNECTIONS R.	MORSETTIERA SCATOLA REMOTA				b

Pos	Code	Factory code	Description	Descrizione	V	W & T	S	Ref/notes
*	096171	0147300900	AMERICAN CANVAS TAPE M50XMM48	NASTRO TELA PLAST. M50XMM48			X	
*	095768	0147017034	PIVILENE INSULATION TAPE; 50X3SP	NASTRO 3M389 NERO (MM19 X 50MT)			X	

*= On demand

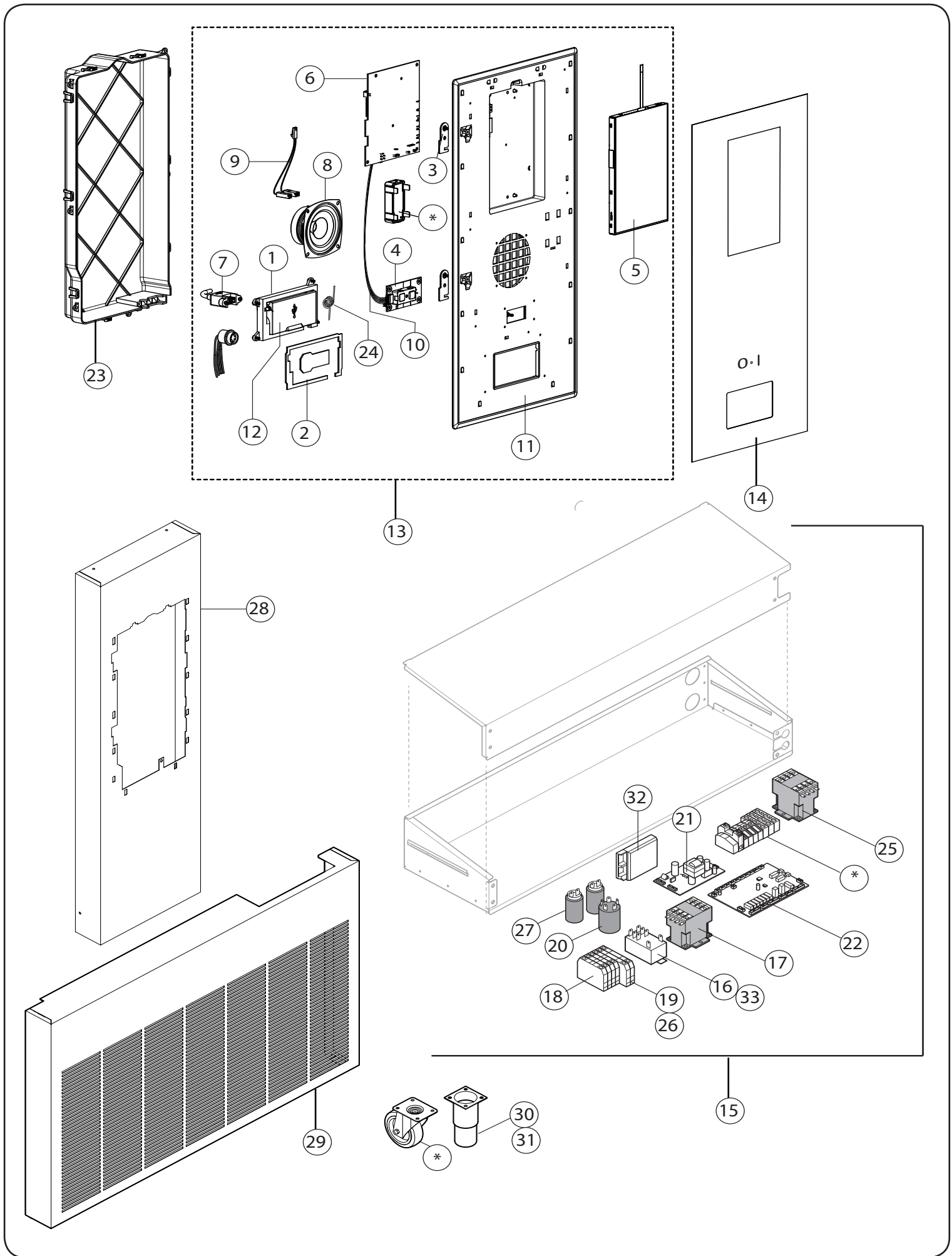

Spare Part Code KIT	Description KIT	Spare Part Code	Spare Part Q.ty	Spare part Description	Descrizione Spare part	Ref./ Note
---------------------	-----------------	-----------------	-----------------	------------------------	------------------------	------------

KIT DI MANUTENZIONE - MAINTENANCE KIT

096167	SKL BCF 50 PM KIT					
		095986	1	DOOR MAGNETIC GASKET BCF50	GUARNIZIONE PORTA	
		095939	2mt	INSULATION FOR THERMOS. VALVE	ISOLAMENTO VALVOLA TERMOSTAT.	Diam. 15
		095938	2mt	INSULATION FOR THERMOS. VALVE	ISOLAMENTO VALVOLA TERMOSTAT.	Diam. 35
		095989	1mt	COIBENTATION PIPES	TUBO ANTICOND. GREY DIAM.16-36	
		095165	1	CLIP OBO 255/3,2 OBO 255.3.2	FERMACAVO OBO 255/3,2 OBO 255.3.2	
		096156	4	SCREW 4,8X70/60 DIN 6928	VITE AUTOFIL. TE FLANG. ZINCATA 4,8X70/60 DIN 6928	