

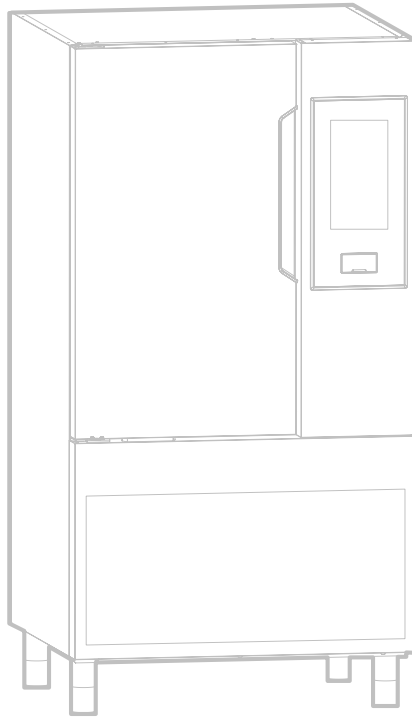

**BLAST CHILLER- FREEZER
ABBATTITORI CONGELATORI**

SKCH 10GN 1_1

Type Reference	Ref	Page	Description	note	Fequency
SKCH50B	a	3_4_5_6_7	BCF 50KG 380V BUILT IN 50 HZ	EU	50 HZ
SKCH50B	d	3_4_5_6_7	BCF 50KG 380V BUILT IN 60 HZ	ROW	60HZ
SKCH50R	b	3_4_5_6_7	BCF 50KG 380V REMOTO 50/60HZ	EU	50/60 HZ
SKCHU50B	c	3_4_5_6_7	BCF 50KG 208V BUILT IN 60 HZ	USA	60HZ



Index

Descriptions type reference/Descrizione di type reference	2
Exploded view internal components/ Vista esplosa componenti interni	3
Exploded view Doors/ Vista esplosa porte	4
Exploded view cooling unit/ Vista esplosa gruppo refrigerante	5
Exploded view cooling unit remote/ Vista esplosa gruppo refrigerante remoto	6
Control panel/pannello comandi	7
Spare part list/Lista ricambi	8-12
Maintenance kit/Kit di manutenzione	13

..Bold= last change/Grassetto =ultima modifica
* on demand = su richiesta

How to put in relation the “Type Ref.” reported on the data plate with the “Type reference” reported on the front page of the Spare Part Catalogue:

The “Type Ref.” represents a group of models/brands all with similar technical features, hence possible to be reported under the same scheme in terms of exploded views.

Electrolux

SKCH

- B= UNIT ON BOARD CONDENSING UNIT
- R= REMOTE CONDENSING UNIT
- 30 = range 30 kg
- 50 = range 50 kg
- 70 = range 70 kg
- 100 = range 100 kg
- 150 = range 150 kg
- 200 = range 200 kg
- SKCH = SKYLINE CHILLER\FREEZER (EUROPA\SAUDI ARABIA\KOREA)
- SKCHU = SKYLINE CHILLER\FREEZER (NORD AMERICA)

ES : **SKCH30B** = range 30 kg gn 1\1 with cooling unit (europa etc.)
SKCH30R = range 30 kg gn 1\1 without cooling unit (remote) (europa etc.)
SKCHU30B = range 30 kg gn 1\1 with cooling unit (nord America)
SKCHU30R = range 30 kg gn 1\1 without cooling unit (remote) (nord America)

Find below an identification example: SKCH30B

F.Mod. PNC 9VTX.....	Comm.Model Ser.Nr.....	Type Ref. SKCH30B	2019
W.Tot. kW	Volt..... Hz.....	Cyclopentane	Total Current A
Evaporation Heater El. kW	Class x	GWP	CO2-eq t
Lighting W	Cap. Refrigerant	Kg	
Defrost Power kW	Heating power kW		
NF nominal Charge			
Rated Pressure Mpa		CE	IPX4
Electrolux Professional SPA - Viale Treviso, 15 - 33170 Pordenone (Italy)			

For the right spare code identification follow the steps:

- 1.Type in the website the PNC reported on the data plate.
- 2.The website will automatically display this spare part catalogue.
- 3.The spare part code at this point is referenced through the “Type reference” as from the front page by the relevant “Ref”.

Come mettere in relazione il “Type Ref.” Riportato sulla targhetta caratteristica con il “Type reference” riportato sul frontespizio del catalogo ricambi:

Il “Type Ref.” Rappresenta un gruppo di modelli/marchi con simili caratteristiche tecniche, ossia possibili da rappresentare con il medesimo schema in termini di vista esplosa.

Electrolux

SKCH

- B= UNITA' CON GRUPPO
- R= UNITA' PREDISPOSTA REMOTA
- 30 = MODELLO 30 kg
- 50 = MODELLO 50 kg
- 70 = MODELLO 70 kg
- 100 = MODELLO 100 kg
- 150 = MODELLO 150 kg
- 200 = MODELLO 200 kg
- SKCH = SKYLINE CHILLER\FREEZER (EUROPA\SAUDI ARABIA\KOREA)
- SKCHU = SKYLINE CHILLER\FREEZER (NORD AMERICA)

ES : **SKCH30B** = range 30 kg gn 1\1 con gruppo (europa etc.)
SKCH30R = range 30 kg gn 1\1 predisposto remoto (europa etc.)
SKCHU30B = range 30 kg gn 1\1 con gruppo (nord America)
SKCHU30R = range 30 kg gn 1\1 predisposto remoto (remote) (nord America)

Qui di seguito un esempio di identificazione: SKCH30B

F.Mod. PNC 9VTX.....	Comm.Model Ser.Nr.....	Type Ref. SKCH30B	2019
W.Tot. kW	Volt..... Hz.....	Cyclopentane	Total Current A
Evaporation Heater El. kW	Class x	GWP	CO2-eq t
Lighting W	Cap. Refrigerant	Kg	
Defrost Power kW	Heating power kW		
NF nominal Charge			
Rated Pressure Mpa		CE	IPX4
Electrolux Professional SPA - Viale Treviso, 15 - 33170 Pordenone (Italy)			

Per identificare il corretto codice ricambio procedere con:

- 1.Digitare nel website il PNC riportato sulla targhetta caratteristica.
- 2.Il website mostrerà automaticamente questo catalogo ricambi.
- 3.A questo punto, il codice ricambio è identificabile attraverso il “Type reference” come indicato nel frontespizio sotto la relativa voce “Ref”.

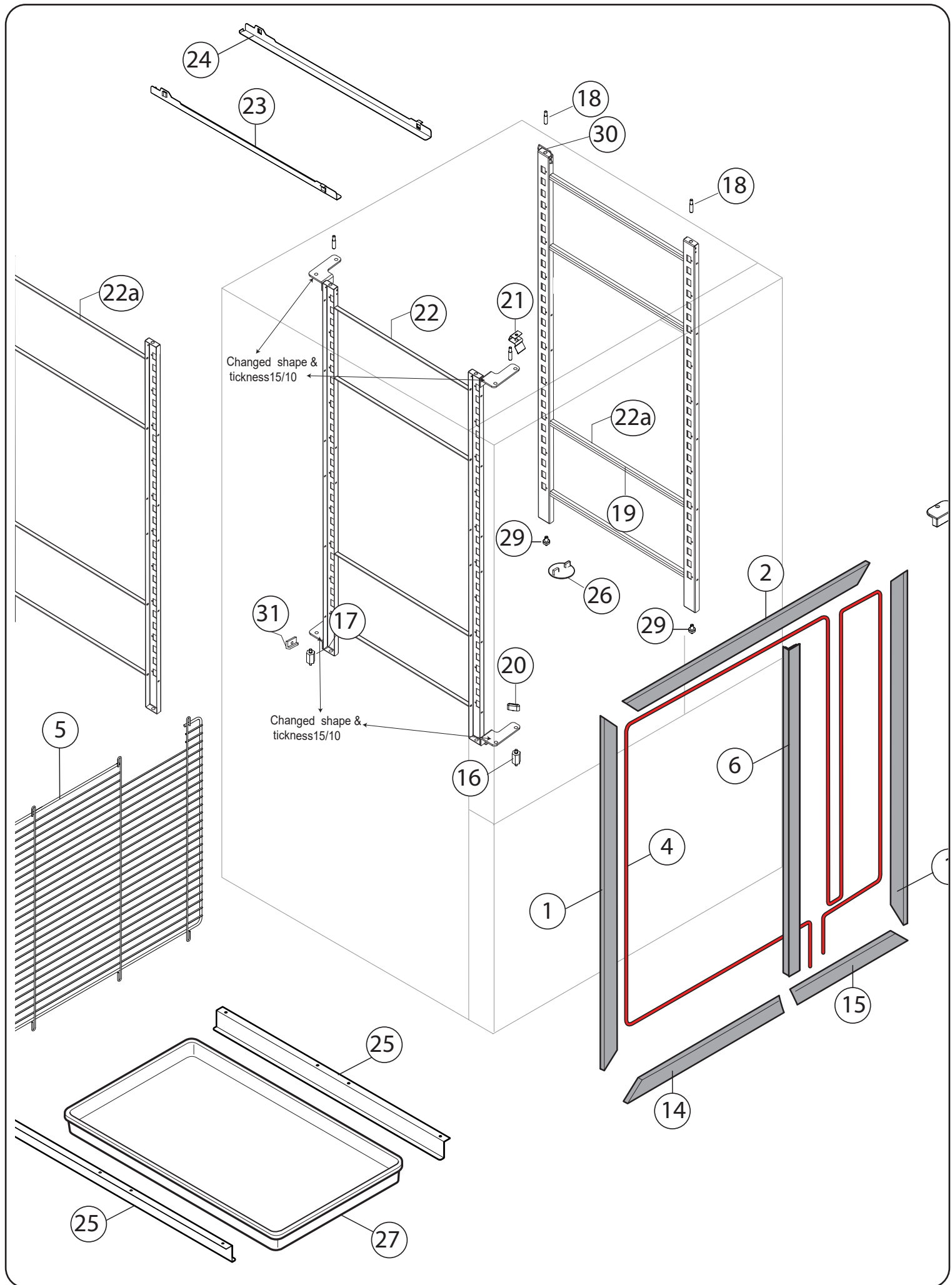

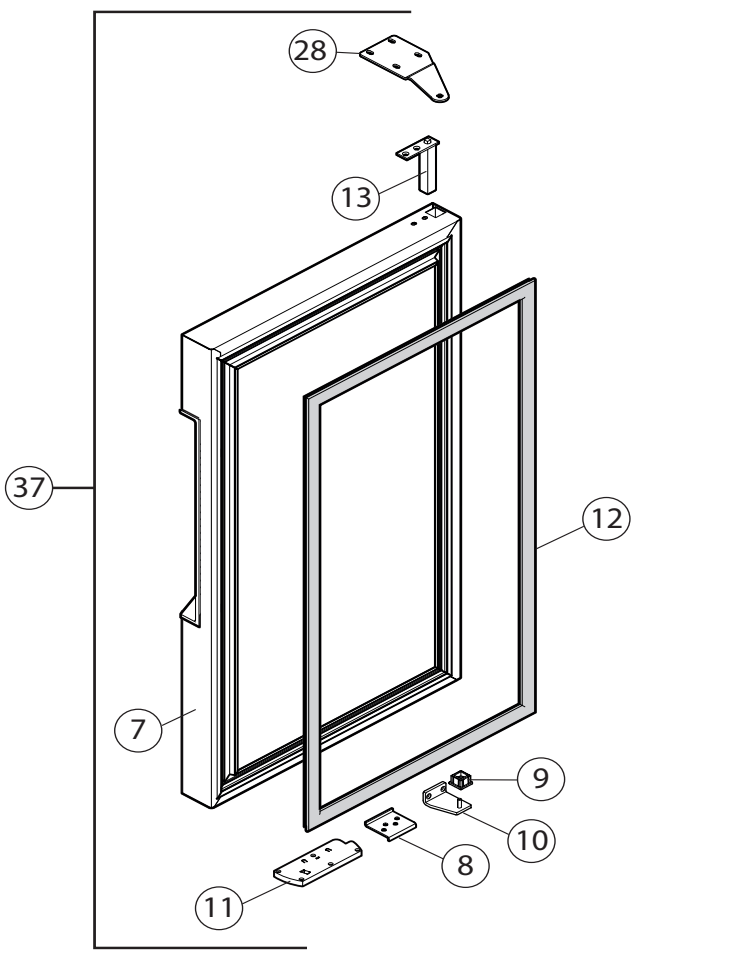

DOOR ELUX LEFT

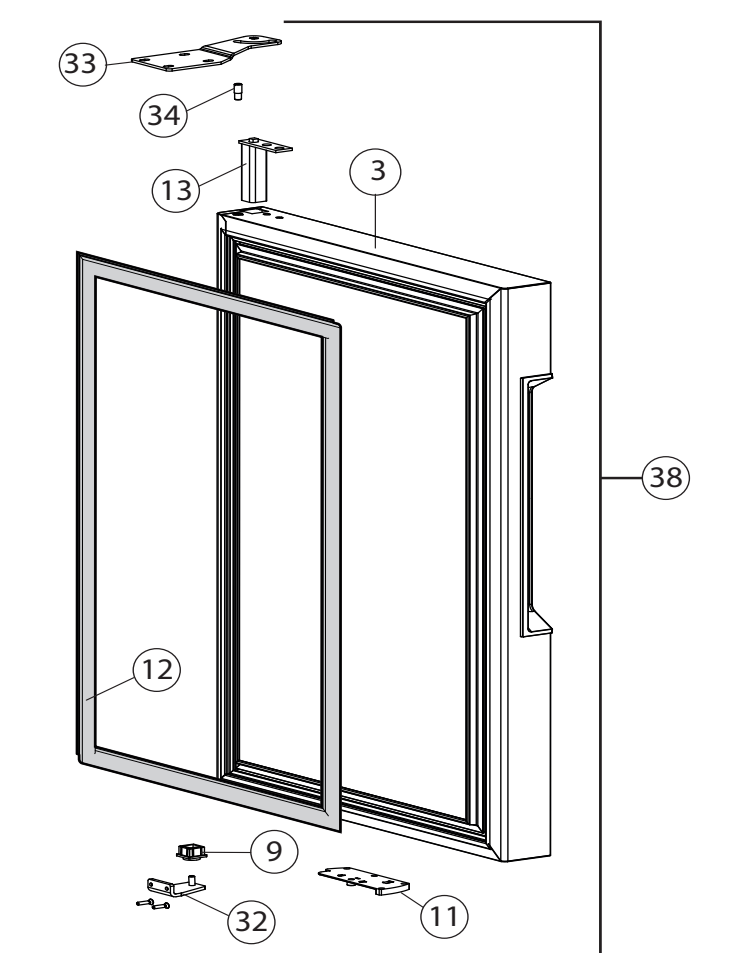

DOOR ELUX RIGHT

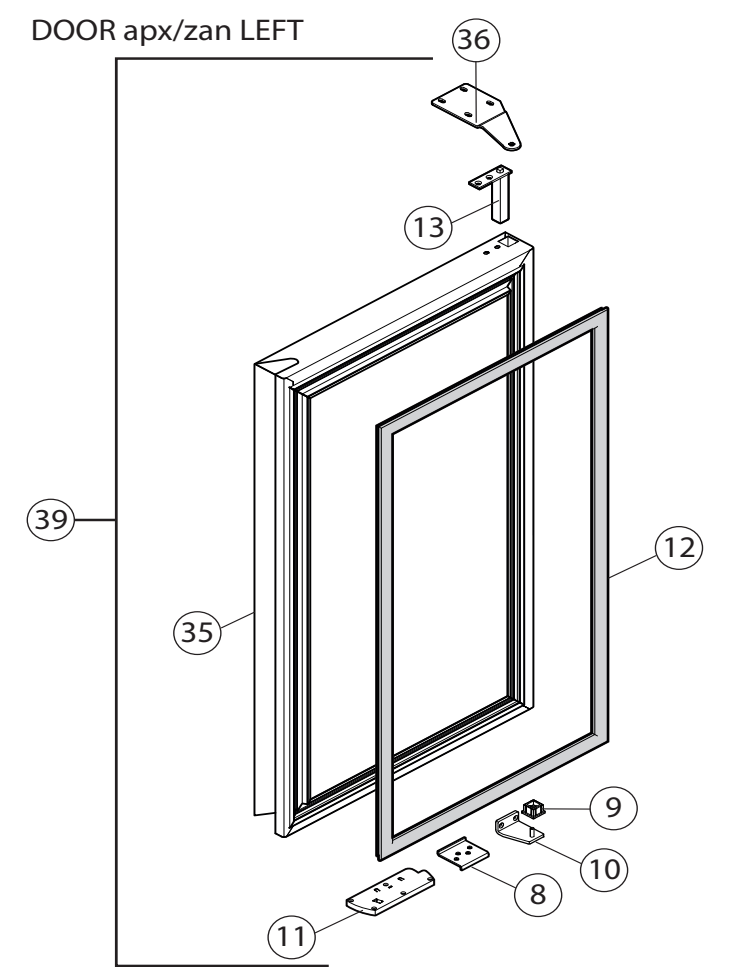

DOOR apx/zan LEFT

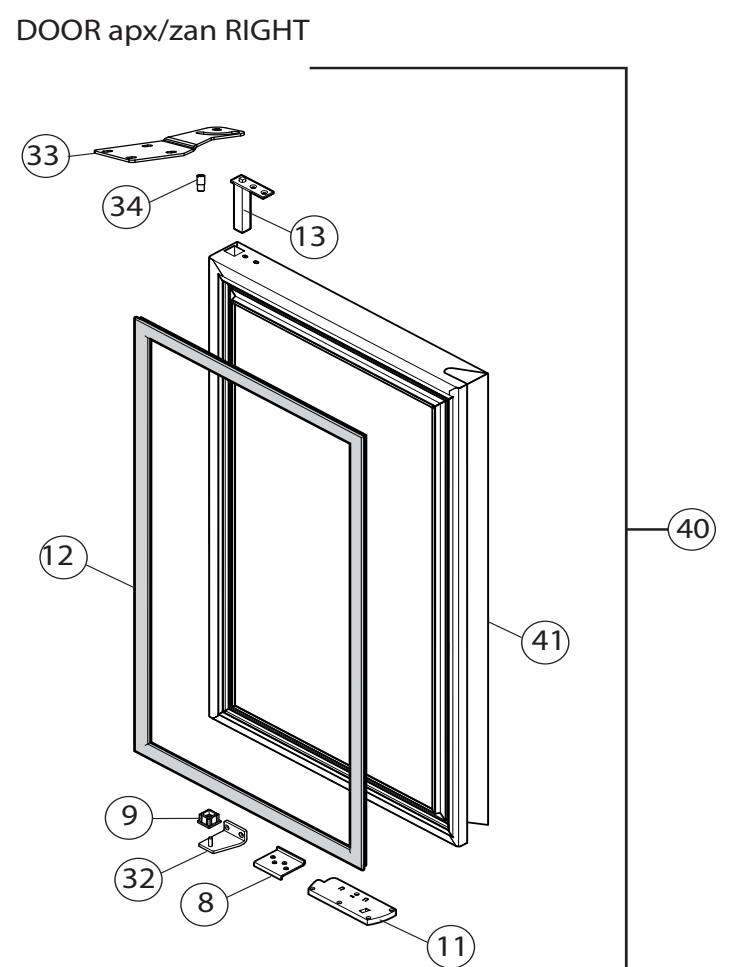

DOOR apx/zan RIGHT

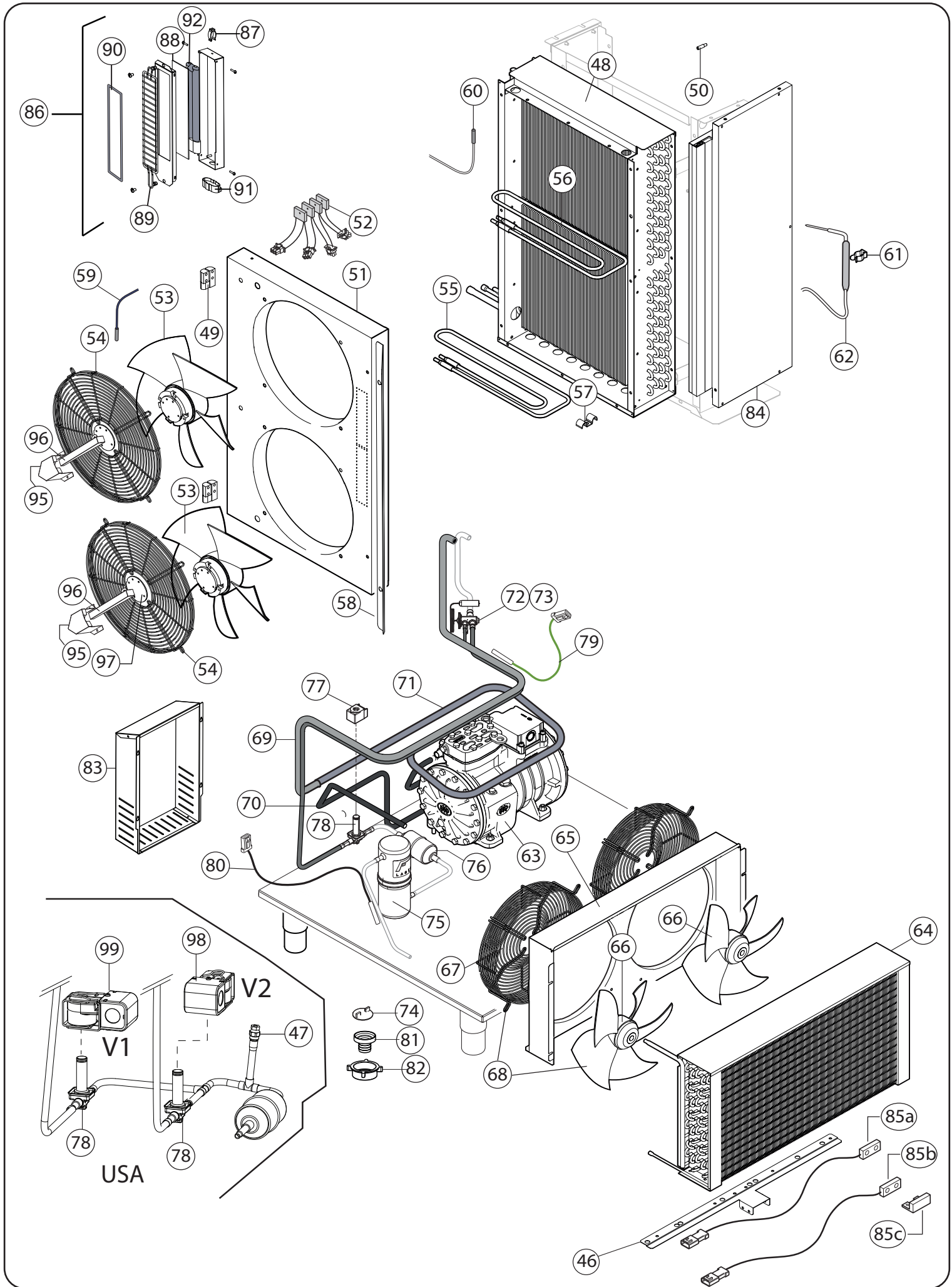

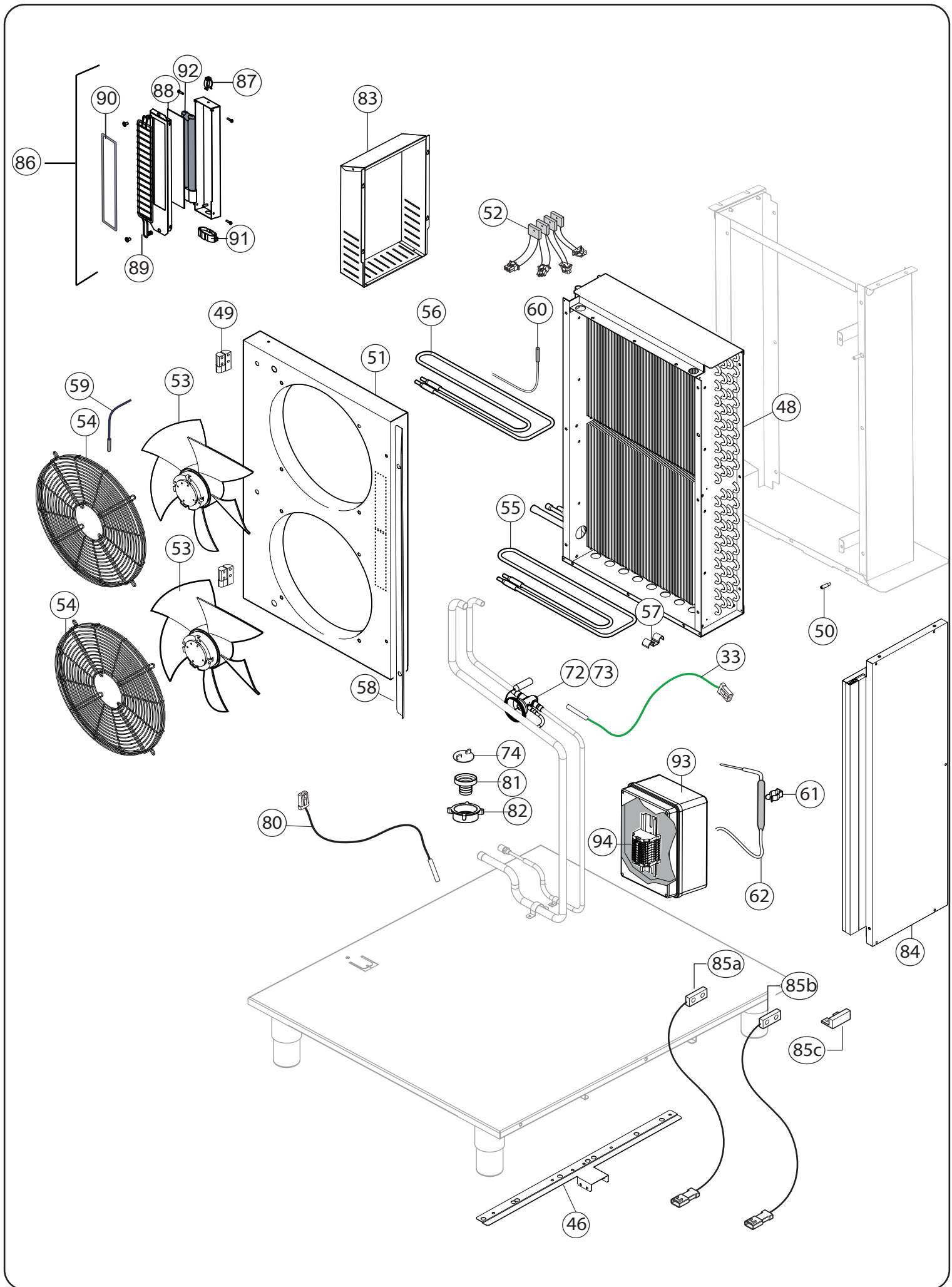

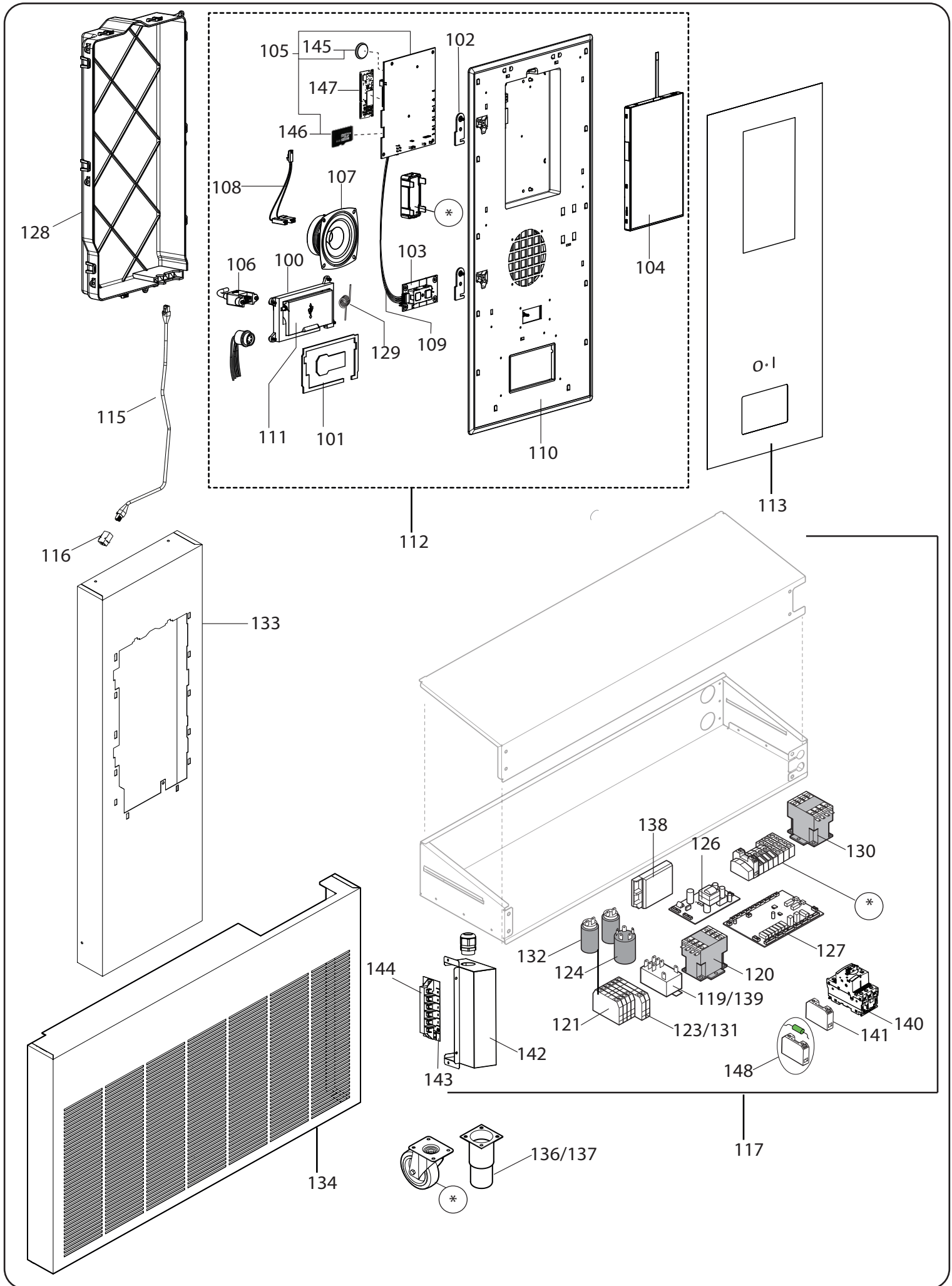

Pos	Code	Factory code	Description	Descrizione	Ref/notes
Reference pag.3&4					
1	095981	0543R17101	ASSEMBLY COVER WITH MAGNET - V	CORNICE VERTICALE	up to week 44 2019 - 901 mm
1	096437	0543R24401	ASSEMBLY COVER WITH MAGNET - V	CORNICE VERTICALE	from week 45 2019 - 902 mm
2	096065	0543R23600	ASSEMBLY COVER WITH MAGNET - H	CORNICE ORIZZONTALE SUP.	up to week 44 2019 - 775 mm
2	096433	0543R23800	ASSEMBLY COVER WITH MAGNET - H	CORNICE ORIZZONTALE SUP.	from week 45 2019 - 775 mm
3	096590	0835R62102	DOOR FOAMED RIGHT ELUX BCF50	PORTA SCHIUMATA DX	ELUX RIGHT ONLY DOOR
4	095991	0617R18401	HEATING ELEMENT CABLE L=4510MM	CAVO RISCALDANTE	a,b,d
4	096383	0617R18700	HEATING ELEMENT CABLE L=4510MM	CAVO RISCALD. USA L=4510MM UL	c
5	095962	0514R26601	REAR PROTECTIVE GRID BCF50 JJ	GRIGLIA POSTERIORE	a,b
5	096427	0514R30200	REAR PROTECTIVE GRID BCF50 JJ	GRIGLIA POSTERIORE	c,d
6	096395	0543R18700	ASSEMBLY COVER WITH MAGNET -V. P.	CORNICE VERTICALE PANNELLO	up to week 44 2019 - 899 mm
6	096442	0543R24900	ASSEMBLY COVER WITH MAGNET -V.P.	CORNICE VERTICALE PANNELLO	from week 45 2019 - 900 mm
7	095915	0835R51004	DOOR FOAMED LEFT ELUX BCF50	PORTA SCHIUMATA SX	ELUX LEFT ONLY DOOR
8	092917	0510789200	LOWER DOOR SUPPORT	PIASTRINA INF.PORTA	
9	0A8856	0544705201	LOWER DOOR BUSH	BOCCOLA X 1/2P INFERIORE	
10	095959	0505R26602	LEFT LOWER HINGE	CERNIERA INFERIORE SX	
11	099909	0835R03800	PLATE DOOR OPEN	ASS. DISP. BLOCCO PORTA APERTA	
12	095986	0548R13400	DOOR MAGNETIC GASKET BCF50	GUARNIZIONE PORTA	
13	083876	0835714501	UPPER HINGE DOOR	CERNIERA CON MOLLA PERNO RIB.	
14	096061	0543R21400	ASSEMBLY COVER WITH MAGNET - H	CORNICE ORIZZONTALE INF. SX	up to week 44 2019 - 536 mm
14	096436	0543R24300	ASSEMBLY COVER WITH MAGNET - H	CORNICE ORIZZONTALE INF. SX	from week 45 2019 - 536 mm
15	096063	0543R21500	ASSEMBLY COVER WITH MAGNET - H	CORNICE ORIZZONTALE INF. DX	up to week 44 2019 - 239 mm
15	096435	0543R24200	ASSEMBLY COVER WITH MAGNET - H	CORNICE ORIZZONTALE INF. DX	from week 45 2019 - 239 mm
16	093935	0514R13301	FRONT RACK SUPPORT	SUPPORTO GUIDE ANT. BCF	
17	093936	0514R13401	BACK RACK SUPPORT	SUPPORTO GUIDE POST. BCF LW	
18	089970	0518713900	PIN FOR RACK	PERNO PER CARTER M6 BCF	
19	096594	0833R50000	RACK SUPPORT ASSEMBLY (RIGHT) 15/10 up to unit week 27/2020	ASS. STRUTTURA DX 15/10 fino a unità prodotte in week 27/2020	Replace code 096037 - Upgrade sturdiness
20	093939	0530R04700	LOCK NUT FOR RACK	CHIAVETTA DI SERRAGGIO	
21	096450	0514R29400	SPRING FOR RACK	MOLLA BLOCCO CREMAGLIERE	
22	096593	0833R49900	RACK SUPPORT ASSEMBLY (LEFT) 15/10 without slide only holes/ up to unit week 27/2020	ASS. STRUTTURA SX 15/10 senza sede di scorrimento solo fori/ fino a unità prodotte in week 27/2020	Replace code 095932 - Upgrade sturdiness
22a	096552	0833R47301	RACK SUPPORT ASSEMBLY (left and right) 15/10	ASS. STRUTTURA DX & SX 15/10	Unit from Week 28 2020 not retrofit
23	096548	0505R08L00	LEFT GUIDE FOR RACK 15/10	GUIDA BCF 30-50KG SX 15/10	Replace code 093862 - Upgrade sturdiness
24	096547	0505R08K00	RIGHT GUIDE FOR RACK 15/10	GUIDA BCF 30-50KG DX 15/10	Replace code 093861 - Upgrade sturdiness
25	089977	0510774302	BASIN GUIDE	GUIDA PER BACINELLA EST	
26	096325	0835r72302	DISCHARGE PLUG DEVICE	ASS. TAPPO SCARICO CELLA JJ	
27	080803	0242452410	BLACK CONDESATE BASIN	BACINELLA RACC.COND.NERO	
28	096054	0505R29600	UPPER HINGE DOOR (LEFT)	CERNIERA SUP.X ABB. SX	
29	095977	0518R09300	LOWER PIN FOR BCF JJ SRUCTURE	PERNO INFERIORE STRUTTURA	
30	095966	0514R28700	LOCKING SPRING	MOLLA DI BLOCCAGGIO CREM.RA	
31	093938	0546R29300	RACK SUPPORT	APPOGGIO PER CREMAGLIERE	
32	095960	0505R26702	RIGHT LOWER HINGE BCF30 JJ	CERNIERA INFERIORE DX	
33	096039	0503R50301	RIGHT UPPER HINGE WITH STOP	CERNIERA SUPERIORE DX	
34	096056	0514R28001	STUD FOR DOOR STOP BCF JJ	PERNO PER FERMO PORTA SUP	
35	096585	0835R68801	FOAMED DOOR LEFT ZAN/APX/TO BR.	PORTA SCHIUMATA SINISTRA	APX/ZAN ONLY DOOR
36	096054	0505R29600	UPPER HINGE DOOR (LEFT)	CERNIERA SUP.X ABB. SX	APX/ZAN LEFT
37	096586	0882R01603	DOOR MODUL LEFT ELUX	MODULO PORTA SINISTRA	ELUX LEFT COMPLETE
38	096097	0882R09401	DOOR MODUL DX ELUX	MODULO PORTA DESTRA	ELUX RIGHT COMPLETE
39	096101	0882R44001	DOOR MODUL SX ZAN/APX	MODULO PORTA SX APX/ZAN	APX/ZAN LEFT COMPLETE

Pos	Code	Factory code	Description	Descrizione	Ref/notes
40	096591	0882R44101	DOOR MOD RIGHT ZAN/APX/TO BRAND	MODULO PORTA DESTRA	ZAN/APX RIGHT COMPLETE
41	096592	0835R68901	FOAMED DOOR DX ZAN/APX/TO BR.	PORTA SCHIUMATA	ONLY DOOR
42	097535	0546R08B00	DOOR GASKET PROTECTION	PROTEZIONE GUARNIZIONE PORTA	
note:					
* N°1_2_6_14_15 = CHANGE THE PROFILE OF THE FRAME COVER FROM WEEK 45 (SER. NUMBER 9451*****)					
Reference pag.5&6					
46	096041	0503R73502	SUPPORT FOR MICROINT. STEM E511	SUPPORTO MICRO PORTA	Up to 2022/28
46	097528	0503R73503	SUPPORT FOR MICROINT. STEM E511	SUPPORTO MICRO PORTA	From 2022/29
47	099869	0646765300	SAFETY BLOW FUSE HP PRESSURE	TAPPO FUSIBILE . FPA-283 UL 1/8'	c
48	096016	0830R12502	FINNED COIL EVAPORATOR BCF50	EVAPORATORE	
49	095979	0530R08100	CARTER HINGE	CERNIERA CARTER VENTILATORI	
50	089970	0518713900	PIN FOR CARTER FAN	PERNO PER CARTER M6	
51	095945	0503R37202	EVAP. CONVEYOR BCF50	CONVOGLIATORE EVAPORATORE	a,b,d without predisp. for UV
51	096048	0504R02500	EVAP. CONVEYOR BCF50 UV LAMP	CONVOGLI. EVAPORATORE UV LAMP	predisposed for uv lamp
51	097530	0504R02502	EVAP. CONVEYOR BCF50 UV LAMP	CONVOGLI. EVAPORATORE UV LAMP	c for uv lamp
51	096445	0504R17900	EVAP. CONVEYOR BCF50 USA	CONVOGLIATORE EVAPORATORE	c without predisp. for UV
52	096340	0652R02800	SAFETY THERMOFUSE 93°C	TERMOFUSIBILE 93°C BCF JJ UL	
53	096011	0682R11801	CAVITY FAN 200/240V L1800 mm 106CC0294	VENTILATORE CELLA 200/240V L1800 mm type 106CC0294	a,b (long cable)
53	096333	0682R13000	CAVITY FAN 106CC302 UL 200/240V 50/60 HZ L 1200mm 106CC302	VENTILATORE CELLA 106CC302 200/240V 50/60 HZ L 1200mm	c,d (short cable)
54	095963	0514R26701	GRID DIAM.380 PAINT	GRIGLIA VENTILATORE CELLA VERN.	a,b
54	096424	0514R29901	GRID DIAM.380 AISI 304	GRIGLIA VENTILATORE CELLA AISI 304	c,d
55	096029	0856R31203	HEATING ELEM. DOWN 380V 50/60Hz	RESISTENZA SBRINAMENTO BASSA	a,b (long cable)
55	096587	0617R03K00	HEATING ELEM. DOWN 380V 50/60Hz	RESISTENZA SBRINAMENTO BASSA	d (short cable)
55	096385	0856R36600	HEATING ELEMENT DOWN UL USA 208V	RESISTENZA SBRINAMEN. BASSA UL	c
56	095923	0856R31403	HEATING ELEMENT UP	RESISTENZA SBRINAMENTO ALTA	a,b (long cable)
56	096334	0856R36400	HEATING ELEMENT UP UL USA 208V	RESISTENZA SBRINAMENTO ALTA UL	c
56	096588	0617R03J00	HEATING ELEMENT UP	RESISTENZA SBRINAMENTO ALTA	d (short cable)
57	048429	0506675402	BRACKET FOR HEATING ELEMENT	SQUADR.FISS.RESIST.VASCA	
58	095940	0501R89200	FRONT DEFLECTOR	DEFLETTORE ANT	
59	096073	0646R21100	CELL PROBE BLUE	SONDA 6X20 BLU 'CELL'	a,b (long cable)
59	096073	0646R21100	CELL PROBE BLUE	SONDA 6X20 BLU 'CELL'	d from 2022/29 (long cable)
59	096335	0646R22400	CELL PROBE BLUE PAINT UL/IEC	SONDA 6X20 BLU 'CELL' VER.O UL/IEC	c (short cable)
59	096335	0646R22400	CELL PROBE BLUE PAINT UL/IEC	SONDA 6X20 BLU 'CELL' VER.O UL/IEC	d up to 2022/28 (short cable)
60	096074	0646R21200	EVAPORATOR PROBE GREY	SONDA 6X40 GRIGIA 'EVAP'	a,b,d (long cable)
60	096336	0646R22500	EVAPORATOR PROBE GREY UL/IEC	SONDA 6X40 GRIGIA 'EVAP' UL/IEC	c (short cable)
61	091800	0639730101	FOOD PROBE HOOK	GANCIO IN AISI 304	
62	096072	0646R20700	FOOD PROBE	SPILLONE CONICO 3 PUNTI SILIC.	a,b,d (long cable)
62	096338	0646R22800	FOOD PROBE UL/IEC	SPILLONE CONICO 3 PUNTI UL/IEC	c (short cable)
63	096013	0684R12300	COMPRESSOR DORIN H281CS 400V	COMPRESSORE H281 CS 400V	a
63	099650	0684730801	COMPRESS. DORIN H281CCK/ UL 208- 230/360-400/3/60	COMPRESSORE H281CCK/ UL 208- 230/360-400/3/60	c,d
64	096015	0830R12402	FINNED COIL CONDENSER BCF50	CONDENSATORE ARIA	a,d
65	095942	0503R10003	CONVEYOR AIR CONDENSER	CONVOGLIATORE CONDENS. 50KG	a,d
66	095895	0682R11600	FAN CONDENSER 230V	VENTILATORE CONDENSATORE	a,d
66	096378	0856R37900	FAN CONDENSER 208 V	VENTILATORE CONDENSATORE	c
67	092853	0514R09700	GRID FAN CONDENSER	GRIGLIA VENTILATORE CONDENSAT.	a,c,d
68	095924	0856R32200	ASS. FAN + GRID EU	ASS.VENTIL ATORE + GRIGLIA	a,d
68	096397	0856R38200	ASS. FAN + GRID USA	ASS.VENTIL ATORE + GRIGLIA USA	c
69	095967	0515R33102	WELDED EXCHANGER BCF50 EU	SCAMBIATORE SALDATO EU	a,d
69	096446	858R17800	WELDED EXCHANGER BCF50 USA	SCAMBIATORE SALDATO USA	c
70	095969	0515R33800	PIPE COMPRES.-CONDENSER BCF50	TUBO DA COMPRES. CONDENS.RE	a,c,d

Pos	Code	Factory code	Description	Descrizione	Ref/notes
71	095970	0515R33900	PIPE COMPRESSOR SUCTION BCF50	TUBO DA EVAP. A COMPRESSORE	a,c,d
72	088347	0646754900	EXPANSION VALVE -40/-15 ORIF.8	VALVOLA TERMOSTATICA	
72		0646R06Q00	EXPANSION VALVE -40/-15 ORIF.8	VALVOLA TERMOSTATICA	R448A/R449A
73	095939	011008R010	INSULATION FOR THERMOS. VALVE	ISOLAMENTO VALVOLA TERMOSTAT.	Diam. 15
73	095938	0110067003	INSULATION FOR THERMOS. VALVE	ISOLAMENTO VALVOLA TERMOSTAT.	Diam. 35
74	096325	0835r72302	DISCHARGE PLUG DEVICE	ASS. TAPPO SCARICO CELLA JJ	
75	087758	0805749401	TANIC RECEIVER	RICEVITORE DI LIQ. A SALD. 0,88 L	a,c,d
76	087438	0805747600	DEHIDRATOR FILTER	FILTRO DCL083S 10MM	a,c,d
77	088351	0646749000	BOB.CLIP 10W EVR6 220-230/50-60	BOBINA VALVOLA SOLENOIDE	a,d
78	084085	0646723000	BODY SOLENOID VALVE	CORPO VALV. EVR 6	a,c,d
79	096005	0646R19201	SUCTION PROBE "GREEN"	SONDA ASPIRAZIONE VERDE	a,b,d (long cable)
79	096339	0646R22600	SUCTION PROBE "GREEN" RES. UL/IEC	SONDA ASPIRAZIONE VERDE UL/IEC	c (short cable)
80	096006	0646R19301	CONDENSER PROBE "BLACK"	SONDA CONDENSATORE NERA	a,c,d
81	094256	0546R26200	RUBBER SUPPORT	PORTAGOMMA	
82	094257	0546R26900	NUT 1'1/2	GHIERA 1'1/2	
83	095961	0505R29302	BACK SPACER PROTECTION	DISTANZIALE /COPERTURA POST.	a,b
83	096240	0505R30900	BACK SPACER PROTECTION	DISTANZIALE /COPERTURA POST.	c,d
84	095916	0835R54903	EVAPORATOR FOAMED PANEL BCF50	PANNELLO SCHIUMATO DI COPERT.	
85a	096002	0640R04101	DOOR MICROSWITCH	MICRO PORTA	
85b	095929	0646R20601	MAGNETIC SENSOR UV LAMP	SENSORE MAGNETICO LAMPADA UV	a UV lamp
85c	087533	0640712000	MAGNET STEM	MAGNETE STEM	a,c UV lamp from 2022/29
86	096075	0832R09501	ASS. UV LAMP	ASSIEME LAMPADA	
86	097537	0832R28500	ASS. UV LAMP	ASSIEME LAMPADA	c with UV lamp
87	084384	0624705200	PLASTIC SPRING	MOLLE PER LAMPADA	
88	093097	0549R05400	GLASS UV	VETRO FRONTALE LAMPADA	
89	093945	0514R11900	PROTECTION	PROTEZIONE	
90	093946	0559R01800	FRONT GASKET	GUARNIZIONE LAMPADA	
91	093948	0665R01100	UV SUPPORT	SUPPORTO LAMPADA	
92	093949	0661R01100	UV LAMP	LAMPADA	
93	096068	0639R19700	GEWISS BOX REMOTE	SCATOLA GEWISS REMOTO	b
94	096071	0639R20000	REMOTE CLAMP CONNECTIONS R.	MORSETTIERA SCATOLA REMOTA	b
95	096447	0504R00900	EXTERNAL PROTECTION FAN CABLE	PROTEZIONE ESTERNA CAVO VENT.	c
96	096448	0504R01001	INTERNAL PROTECTION FAN CABLE	PROTEZIONE INTERNA CAVO VENT.	c
97	096449	0504R01100	FAN COVER PROTECTION	PROTEZIONE PER VENTILATORE	c
98	096241	0830R02A01	SOLENOID VALVE COIL V2	BOBINA VALVOLA SOLENOIDE V2	c (red connector)
99	096423	0856R38101	SOLENOID VALVE COIL V1	BOBINA VALVOLA SOLENOIDE V1	c (white connector)
	096171	0147300900	AMERICAN CANVAS TAPE M50XMM48	NASTRO TELA PLAST. M50XMM48	
	095768	0147017034	PVILENE INSULATION TAPE; 50X3SP	NASTRO 3M389 NERO (MM19 X 50MT)	
note:					
N° 98_99 ,the coil of solenoid valve are the same change only the color of connector , white for V1 and Red for V2					
Reference pag.7					
100	0CK030	0546400U01	DRAWER USB SUPPORT	CKM SEDE USB	
101	0CK031	0543401P02	GASKET DRAWER USB SUPPORT	GUARNIZIONE SEDE USB	
102	0CK432	0506405M00	PANEL HOOK	GANCIO PANNELLO	
103	0CK033	0675401G00	ON/OFF BOARD	SCHEDA ON/OFF	
104	0CK034	0673400900	DISPLAY JDI 7""	DISPLAY JDI 7"" TP RESISTIVO	
105	0CK036	0675401J01	BRIDGE BOARD	SCHEDA CONNESSIONE DISPLAY	
*	0CK674	675403M00	MICROSD HC 8GB CL4 SANDISK	MICROSD HC 8GB CL4 SANDISK	
106	0CK037	0638404D00	WIRING USB	CAVO USB	
107	0CK039	0655400000	SPEAKER VISATON	ALTOPARLANTE	
108	0CK330	0675401L00	WIRING SPEAKER	CAVETTO CONNESSIONE SPEAKER	

Pos	Code	Factory code	Description	Descrizione	Ref/notes
109	0CK045	0675401Q00	WIRING ON/OFF BOARD	CAVETTO ON-OFF TOUCH	
110	0CK040	0543401N01	PLASTIC FRAME TOUCH	PANNELLO IN PLASTICA	
111	0CK041	0546400V01	USB COVER	SPORTELLINO USB ELUX	
112	0CK685	083040PL01	ASS. TOUCH UI WITH ETHERNET DIRECT CONNECTION	PANNELLO COMPLETO UI CON CONNESSIONE ETHERNET	only unit with peer to peer/collegamento cavo lan diretto
112	0CK661	083040PG01	ASS. TOUCH UI	PANNELLO COMPLETO UI	all units
113	095934	0755R13902	ADHESIVE DECOR TOUCH	MEMBRANA ADESIVA	ELUX (ORDER ALSO N°110)
113	095936	0755R16202	ADHESIVE DECOR TOUCH	MEMBRANA ADESIVA	APX (ORDER ALSO N°110)
113	095935	0755R16103	ADHESIVE DECOR TOUCH	MEMBRANA ADESIVA	ZAN (ORDER ALSO N°110)
113	096058	0541401V02	ADHESIVE DECOR TOUCH	MEMBRANA ADESIVA	TO BRAND (ORDER ALSO N°110)
115	0CB910	0638406L00	CAVO ETHERNET RJ45 M-M CAT.5E SCHERMATO L=1000MM	ETHERNET CABLE RJ45 M-M CAT.5E L=1000MM	
116	0CB911	0639402900	GIUNTO RJ45 - VS-08-BU-RJ45/BU - PHOENIX 1689064	CONNECTION RJ45 - VS-08-BU-RJ45/BU - PHOENIX 1689064	
117	096079	0882R19006	ELECTRICAL BOX COMPLETE	SCATOLA ELETTRICA COMPLETA	without uv lamp
117	096083	0882R86201	ELECTRICAL BOX COMPLETE	SCATOLA ELETTRICA COMPLETA	for uv lamp
117	096574	0883R11002	ELECTRICAL BOX COMPLETE	SCATOLA ELETTRICA COMPLETA	c
117	097541	0883R72100	ELECTRICAL BOX COMPLETE	SCATOLA ELETTRICA COMPLETA	c for UV lamp from 2022/29
117	096589	0883R28301	ELECTRICAL BOX COMPLETE	SCATOLA ELETTRICA COMPLETA	d
117		0883R41500	ELECTRICAL BOX COMPLETE	SCATOLA ELETTRICA COMPLETA	Peer to peer prod.
119	093848	0648R06300	RELAY 66.82.8.230.0001 COIL 230V	RELE' FINDER 230V 30A &10A	a,b,d PIN 11-14 30A 11-12 10A
120	088477	0648807300	CONTACTOR K3-10A10 230V	CONTATTORE K3-10A10 230V 50/60HZ	a,d
120	099090	0648729200	CONTACTOR K3-22 (COIL 200-240/60)	CONTATTORE K3-22 (COIL 200-240/60)	c
121	096000	0639R18401	MAIN TERMINAL BLOCK	BLOCCHETTI DI CONNESSIONE ELET.	a,d
121	096070	0639R19900	MAIN TERMINAL BLOCK	BLOCCHETTI DI CONNESSIONE ELET.	b
121	096388	0639R22600	MAIN TERMINAL BLOCK	BLOCCHETTI DI CONNESSIONE ELET.	c
123	095933	0652R02400	GLASS FUSE 10A T 5X20	FUSIBILE IN VETRO 10A T 5X20	
123	0L3083	0652608900	CERAMICS FUSE 10A T 5X20 250V	FUSIBILE IN CERAMICA 10A T 5X20	c,d
124	059078	0694502400	FILTRO LC	FILTRO LC	for uv lamp and for peer to peer
124	084987	0694700800	RFI FILTER	FILTRO ANTIDISTURBO	without uv lamp
126	095639	0648R10000	POWER SUPPLY 12V 30W	SCHEDA DI POTENZA 12V 30W	
126	096342	0648R11400	POWER SUPPLY 12V/100W UL	SCHEDA DI POTENZA 12V/100W UL	c
127	096010	0648R08602	ACU PETRA BCF	SCHEDA PRINCIPALE PETRA	up to 2020/20 canceled
127	096557	0648R10900	ACU PETRA BCF - BITRON	SCHEDA PRINCIPALE PETRA-BITRON	from 2020/21
128	0CK161	0541401D01	PROTECTION COMAND PANEL	PROTEZIONE PANNELLO COMANDI	
129	0CK032	0514405001	SPRING DOOR USB	MOLLA SPORTELLINO USB	
130	088477	0648807300	CONTACTOR K3-10A10 230V	CONTATTORE K3-10A10 230V 50/60HZ	a,d
131	093564	0639732800	FUSE SUPPORT	MORSETTO2 VIE X PORTAFUSIBILE	
132	096009	0648730000	FAN CAPACITOR 3 mF	CONDENSATORE 3MFPER VENT.	a,d
132	099129	0648729400	FAN CAPACITOR 4MF UL-CSA	CONDENSATORE 4MF UL-CSA VENT.	c
133	095941	0502R94703	CONTROL PANEL BCF50	PANNELLO DI CONTROLLO SS	
134	095943	0503R21803	CONDENSER PANEL BCF50	PANNELLO CONDENSATORE	ELUX only
134	096044	0503R91102	CONDENSER PANEL BCF50	PANNELLO CONDENSATORE	ALL BRAND
136	048579	0855631900	FEET LG.153	ASS.PIEDE LG.153	a,b,d
136	096236	0833R48700	FEET H150/200	ASS.PIEDE LG.H150/200	c
137	095926	0882R01200	KIT 4 FEET + SCREWS	KIT 4 PIEDINI CON VITI E DADI	a,b,d
137	096243	0883R09200	KIT 4 FEET + SCREWS	KIT 4 PIEDINI CON VITI E DADI	c
138	093950	0624R01600	POWER VOLTAGE ADAPTOR UV BULB	ALIMENTATORE UV LAMPADA	for uv lamp
138	097536	0624R00J00	POWER VOLTAGE ADAPTOR UV BULB	ALIMENTATORE UV LAMPADA	c for UV lamp
139	006610	0648806900	RELE'62.838.230.0009+ATT.BARRA	RELE' +ATT.BARRA DIN OPP	b
140	093194	0640R01900	OVER CURRENT PROTECTION SWITCH	SALVAM. ABB MS132-20 (16...20A	c
141	091725	0640R01000	AUXILIARY SWICHT PROT. OVER CU.	CONTATTI AUSILIARI HK1-11 SALVA.	c

Pos	Code	Factory code	Description	Descrizione	Ref/notes
142	096444	0505R31500	TERMINAL BLOCK COVER	COPERTURA MORSETTIERA	c
143	097526	0598610500	TERMINAL BLOCK PLATE	TARGHETTA MORSETTIERA 6 POLI	c
144	088165	0639726600	TERMINAL BLOCK	MORSETTIERA	c
145			BATTERY CR2032 V3 LITIO	BATTERIA MODELLO CR 2032 V3 LITIO	
146			MICRO SD 4G o more biger 4HC	MICRO SD 4G o piu' grande 4HC	
147	0CK035	0675401H00	CORE BOARD DAVE	TOUCH	
148		0835R33T00	KIT UV LAMP RECOVERY	KIT UV LAMP RECOVERY	UV lamp from 2022/29 - See Tech. Sheet VTX2022_02

BLAST CHILLER FREEZER						CHILL ^S 50 KG
Pos	Code	Factory code	Description	Descrizione	Ref/notes	
BLAST CHILLER FREEZER						CHILL ^S 50 KG
KIT DI MANUTENZIONE – MAINTENANCE KIT						
Spare Part Code KIT	Description KIT	Spare Part Code	Spare Part Q.ty	Spare part Description	Descrizione Spare part	Ref./ Note
KIT DI MANUTENZIONE - MAINTENANCE KIT						
096167	SKL BCF 50 PM KIT					
		095986	1	DOOR MAGNETIC GASKET BCF50	GUARNIZIONE PORTA	
		095939	2mt	INSULATION FOR THERMOS. VALVE	ISOLAMENTO VALVOLA TERMOSTAT.	Diam. 15
		095938	2mt	INSULATION FOR THERMOS. VALVE	ISOLAMENTO VALVOLA TERMOSTAT.	Diam. 35
		095989	1mt	COIBENTATION PIPES	TUBO ANTICOND. GREY DIAM.16-36	
		095165	1	CLIP OBO 255/3,2 OBO 255.3.2	FERMACAVO OBO 255/3,2 OBO 255.3.2	
		096156	4	SCREW 4,8X70/60 DIN 6928	VITE AUTOFIL. TE FLANG. ZINCATA 4,8X70/60 DIN 6928	

Electrolux Professional SpA
Viale Treviso, 15
33170 Pordenone, ITALY
Fax (+39) 0434 380 201
<https://www.electroluxprofessional.com>
<https://webgate.electroluxprofessional.com>