

**BLAST CHILLER- FREEZER
ABBATTITORI CONGELATORI**

SKCH 10GN 2_1

Type Reference	Ref	Page	Description	note
SKCH70B	a	3_4_6_10	BCF 70KG 380V BUILT IN 50 HZ	
SKCH70R	b	3_4_7_10	BCF 70KG 380V REMOTO 50/60HZ	

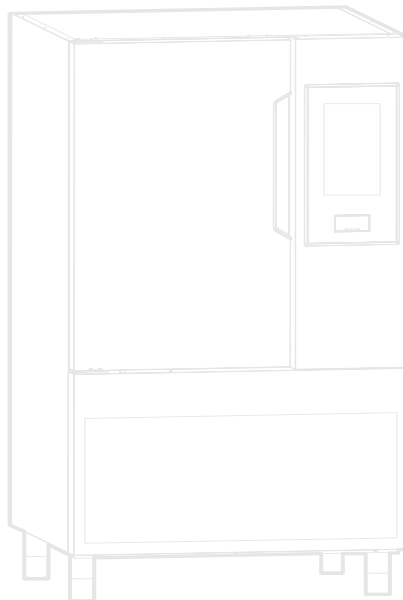

Index

	Page
Descriptions type ref/Descrizione el Type refence	2
Exploded view internal components/ Vista esplosa componenti interni	3
Exploded view Doors/ Vista esplosa porte	4
Spare part list/Lista ricambi	5
Exploded view cooling unit/ Vista esplosa gruppo refrigerante	6
Exploded view cooling unit remote/ Vista esplosa gruppo refrigerante remoto	7
Spare part list/Lista ricambi	8,9
Control panel/pannello comandi	10
Spare part list/Lista ricambi	11
Maintenance kit/Kit di manutenzione	12

...**Bold**= last change/Grassetto =ultima modifica

V = Vital spare part/Ricambio vitale

W&T = Wear&Tear and Consumable/Ricambio usurabile e consumabile

S = Suggested/Ricambio suggerito

Bold=last change / Grassetto =ultima modifica

Rev. 2

From Ser. Nr.... Up to Ser. Nr....	Ed. 2019-03 Updated 2019-06	Page: 1	Doc No: 595R42600
---------------------------------------	--------------------------------	---------	--------------------------

How to put in relation the “Type Ref.” reported on the data plate with the “Type reference” reported on the front page of the Spare Part Catalogue:

The “Type Ref.” represents a group of models/brands all with similar technical features, hence possible to be reported under the same scheme in terms of exploded views.

Electrolux

SKCH

- B= UNIT ON BOARD CONDENSING UNIT
- R= REMOTE CONDENSING UNIT
- 30 = range 30 kg
- 50 = range 50 kg
- 70 = range 70 kg
- 100 = range 100 kg
- 150 = range 150 kg
- 200 =range 200 kg
- SKCH = SKYLINE CHILLER\FREEZER (EUROPA\SAUDI ARABIA\KOREA)
- SKCHU = SKYLINE CHILLER\FREEZER (NORD AMERICA)

ES : **SKCH30B** = range 30 kg gn 1\1 with cooling unit (europa etc.)
SKCH30R = range 30 kg gn 1\1 without cooling unit (remote) (europa etc.)
SKCHU30B = range 30 kg gn 1\1 with cooling unit (nord America)
SKCHU30R = range 30 kg gn 1\1 without cooling unit (remote) (nord America)

Find below an identification example: SKCH30B

F.Mod. PNC 9VTX.....	Comm.Model Ser.Nr.....	Type Ref. SKCH30B	2019
W.Tot. kW	Volt.....	Hz.....	Cyclopentane Total Current A
Evaporation Heater El. kW	Class x	GWP	CO2-eq t
Lighting W	Cap.	Refrigerant	Kg
Defrost Power kW	Heating power kW		
NF nominal Charge			
Rated Pressure Mpa		CE	WEEE
IPX4			
Electrolux Professional SPA - Viale Treviso, 15 - 33170 Pordenone (Italy)			

For the right spare code identification follow the steps:

- 1.Type in the website the PNC reported on the data plate.
- 2.The website will automatically display this spare part catalogue.
- 3.The spare part code at this point is referenced through the “Type reference” as from the front page by the relevant “Ref”.

Come mettere in relazione il “Type Ref.” Riportato sulla targhetta caratteristica con il “Type reference” riportato sul frontespizio del catalogo ricambi:

Il “Type Ref.” Rappresenta un gruppo di modelli/marchi con simili caratteristiche tecniche, ossia possibili da rappresentare con il medesimo schema in termini di vista esplosa.

Electrolux

SKCH

- B= UNITA' CON GRUPPO
- R= UNITA' PREDISPOSTA REMOTA
- 30 = MODELLO 30 kg
- 50 = MODELLO 50 kg
- 70 = MODELLO 70 kg
- 100 = MODELLO 100 kg
- 150 = MODELLO 150 kg
- 200 = MODELLO 200 kg
- SKCH = SKYLINE CHILLER\FREEZER (EUROPA\SAUDI ARABIA\KOREA)
- SKCHU = SKYLINE CHILLER\FREEZER (NORD AMERICA)

ES : **SKCH30B** = range 30 kg gn 1\1 con gruppo (europa etc.)
SKCH30R = range 30 kg gn 1\1 predisposto remoto (europa etc.)
SKCHU30B = range 30 kg gn 1\1 con gruppo (nord America)
SKCHU30R = range 30 kg gn 1\1 predisposto remoto (remote) (nord America)

Qui di seguito un esempio di identificazione: SKCH30B

F.Mod. PNC 9VTX.....	Comm.Model Ser.Nr.....	Type Ref. SKCH30B	2019
W.Tot. kW	Volt.....	Hz.....	Cyclopentane Total Current A
Evaporation Heater El. kW	Class x	GWP	CO2-eq t
Lighting W	Cap.	Refrigerant	Kg
Defrost Power kW	Heating power kW		
NF nominal Charge			
Rated Pressure Mpa		CE	WEEE
IPX4			
Electrolux Professional SPA - Viale Treviso, 15 - 33170 Pordenone (Italy)			

Per identificare il corretto codice ricambio procedere con:

- 1.Digitare nel website il PNC riportato sulla targhetta caratteristica.
- 2.Il website mostrerà automaticamente questo catalogo ricambi.
- 3.A questo punto, il codice ricambio è identificabile attraverso il “Type reference” come indicato nel frontespizio sotto la relativa voce “Ref”.

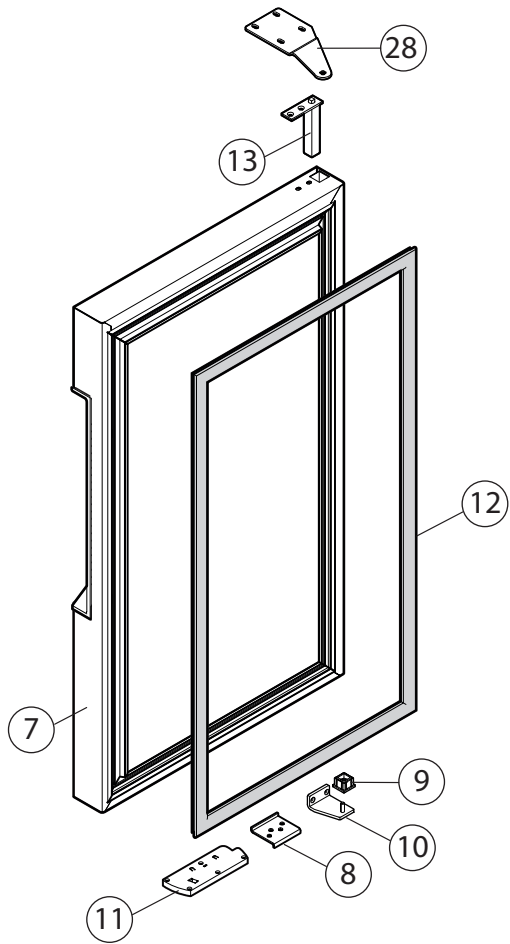

DOOR ELUX LEFT

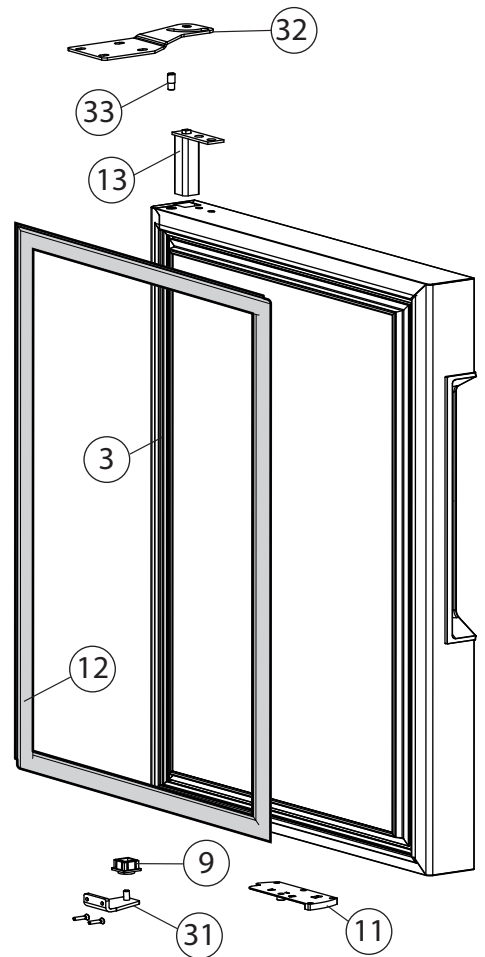

DOOR ELUX RIGHT

DOOR apx/zan LEFT

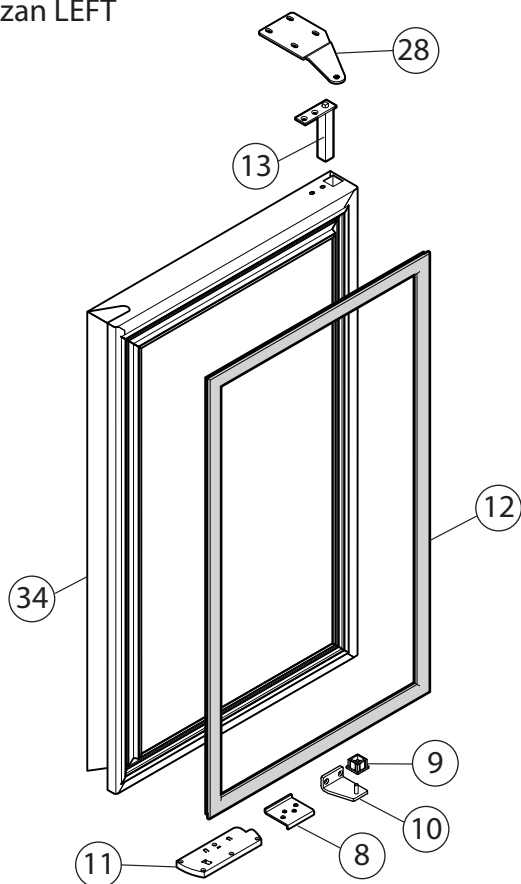

Pos	Code	Factory code	Description	Descrizione	V	W & T	S	Ref/notes
Reference pag.3-4								
1	095981	0543R17101	ASSEMBLY COVER WITH MAGNET - V	CORNICE VERTICALE				
2	096066	0543R23700	ASSEMBLY COVER WITH MAGNET - H	CORNICE ORIZZONTALE SUP.				
3	096099	0882R18800	DOOR RIGHT ELUX BCF70 ASS.Y	ASS. PORTA DX				ELUX RIGHT
4	048579	0855631900		ASS.PIEDE LG.153				
6		0543R18700	ASSEMBLY COVER WITH MAGNET - V P	CORNICE VERTICALE PANNELLO SCH.				
7	096096	0882R18703	DOOR LEFT ELUX BCF70 ASS.Y	ASS. PORTA SX				
8	092917	0510789200	LOWER DOOR SUPPORT	PIASTRINA INF.PORTA				
9	0A8856	0544705201	LOWER DOOR BUSH	BOCCOLA X 1/2P INFERIORE	X			
10	095914	0832R23402	LEFT LOWER HINGE	CERNIERA INFERIORE SX				
11	099909	0835R03800	PLATE DOOR OPEN	ASS. DISP. BLOCCO PORTA APERTA				
12	095987	0548R13500	DOOR MAGNETIC GASKET BCF70	GUARNIZIONE PORTA	X	X		
13	083876	0835714501	UPPER HINGE DOOR	CERNIERA CON MOLLA PERNO RIB.	X	X		
14	096059	0543R21200	ASSEMBLY COVER WITH MAGNET - H	CORNICE ORIZZONTALE INF. SX				
15	096060	0543R21300	ASSEMBLY COVER WITH MAGNET - H	CORNICE ORIZZONTALE INF. DX				
16	093935	0514R13301	FRONT RACK SUPPORT	SUPPORTO GUIDE ANT. BCF				
17	093936	0514R13401	BACK RACK SUPPORT	SUPPORTO GUIDE POST. BCF LW				
18	089970	0518713900	PIN FOR RACK	PERNO PER CARTER M6 BCF				
19	096038	0833R47500	GRID ASSEMBLY	ASS. CREMAGLIERA 70KG LW				
20	093939	0530R04700	LOCK NUT FOR RACK	CHIAVETTA DI SERRAGGIO		X		
21	093974	0514R16400	SPRING FOR RACK	MOLLA BLOCCO CREMAGLIERE		X		
22	096077	0833R47400	GRID ASSEMBLY	CREMAGLIERA				
23	093994	0501R73200	LEFT GUIDE FOR RACK	GUIDA BCF 30-50KG SX				
24	093995	0501R73300	RIGHT GUIDE FOR RACK	GUIDA BCF 30-50KG DX				
25	089977	0510774302	BASIN GUIDE	GUIDA PER BACINELLA EST				
26	093934	0546R27300	PLUG	TAPPO FONDO BCF	X	X		
27	080803	0242452410	BLACK CONDESATE BASIN	BACINELLA RACC.COND.NERO		X		
28	096055	0505R29700	UPPER HINGE DOOR LEFT	CERNIERA SUP.X ABB. SX				
29	095977	0518R09300	LOWER PIN FOR BCF JJ SRUCTURE	PERNO INFERIORE STRUTTURA				
30	093938	0546R29300	RACK SUPPORT	APPOGGIO PER CREMAGLIERE		X		
31	096076	0832R23500	RIGHT LOWER HINGE BCF70 JJ	CERNIERA INFERIORE DX				
32	096039	0503R50300	RIGHT UPPER HINGE WITH STOP	CERNIERA SUPERIORE DX				
33	096056	0514R28000	STUD FOR DOOR STOP BCF JJ	PERNO PER FERMO PORTA SUP				
34	096100	0882R43800	DOOR SX ZAN/APX BCF70 JJ ASS.Y	ASS. PORTA SX APX/ZAN				APX/ZAN LEFT
35	096054	0505R29600	UPPER HINGE DOOR	CERNIERA SUP.X ABB. SX				APX/ZAN LEFT
36	095966	0514R28700	LOCKING SPRING BCF JJ	MOLLA FISSAGGIO CREMAGLIERA DX				

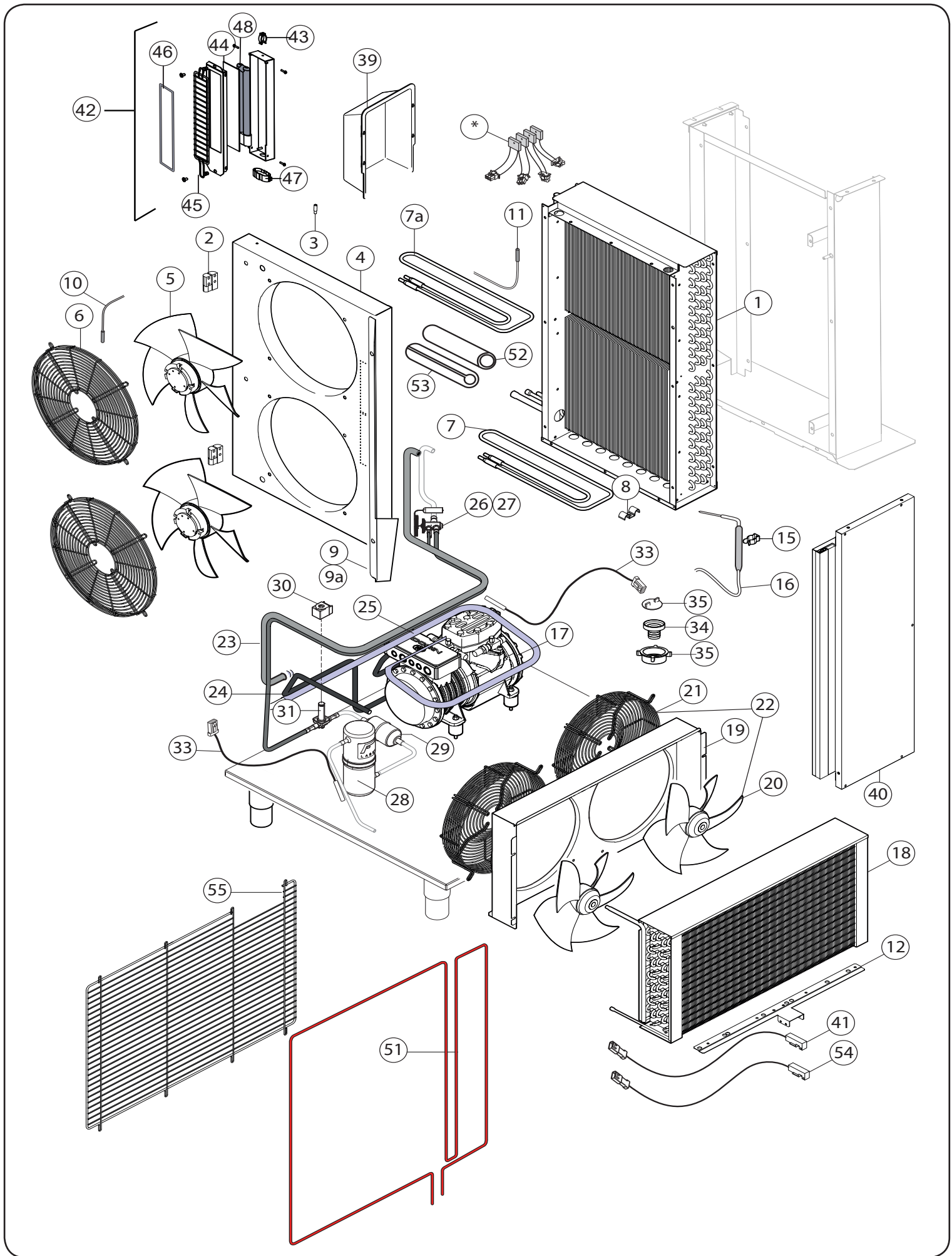

Pos	Code	Factory code	Description	Descrizione	V	W & T	S	Ref/notes
reference pag. 6-7								
1	095911	0830R13802	FINNED COIL EVAPORATOR BCF 70	EVAPORATORE	X			
2	095979	0530R08101	CARTER HINGE	CERNIERA CARTER VENTILATORI				
3	089970	0518713900	PIN FOR CARTER FAN	PERNO PER CARTER M6				
4	095949	0503R49403	EVAP. CONVEYOR BCF	CONVOGLIATORE EVAPORATORE				without predisp. for UV
4	096049	0504R02600	EVAP. CONVEYOR BCF70 UV LAMP	CONVOGLI. EVAPORATORE UV LAP				predisposed for uv lamp
5	096011	0682R11801	CAVITY FAN	VENTILATORE CELLA	X			
6	095963	0514R26701	GRID DIAM.380	GRIGLIA VENTILATORE CELLA				
7	095921	0856R31102	HEATING ELEMENT DOWN 800 W	RESISTENZA SBRINAMENTO BASSA	X	X		
7a	095922	0856R31302	HEATING ELEMENT UP 800 W	RESISTENZA SBRINAMENTO ALTA	X	X		
8	048429	0506675402	BRACKET FOR HEATING ELEMENT	SQUADR.FISS.RESIST.VASCA				
9	095956	0504R00500	FRONT DEFLECTOR	DEFLETTORE ANT				
9	095957	0504R00600	REAR DEFLECTOR	DEFLETTORE POST				
10	096073	0646R21100	CELL PROBE BLUE	SONDA 6X20 BLU 'CELL'	X	X		
11	096074	0646R21200	EVAPORATOR PROBE GREY	SONDA 6X40 GRIGIA 'EVAP'		X		
12	096041	0503R73502	SUPPORT FOR MICROINTERR.	STAFFA PER MICRO PORTA				
15	091800	0639730101	FOOD PROBE HOOK	GANCIO IN AISI 304				
16	096072	0646R20700	FOOD PROBE	SPILLONE CONICO 3 PUNTI SILIC.		X		
17	089989	0684728100	COMPRESSOR DORIN H390CS	COMPRESSORE H390CS	X			a
18	096917	0830R13202	FINNED COIL CONDENSER BCF50	CONDENSATORE ARIA	X			a
19	095947	0503R49102	CONVEYOR AIR CONDENSER	CONVOGLIATORE CONDENS. 50KG				a
20	095896	0682R11900	FAN CONDENSER	VENTILATORE CONDENSATORE	X			a
21	090022	0514760800	GRID FAN CONDENSER	GRIGLIA VENTILATORE CONDENSAT.				a
22	095925	0856R32300	ASS. FAN + GRID	ASS.VENTILATORE + GRIGLIA				a
23		*	WELDED EXCHANGER BCF50	SCAMBIATORE SALDATO				a
24		*	PIPE COMPRES.-CONDENSER BCF50	TUBO DA COMPRES. CONDENS.RE				a
25		*	PIPE COMPRESSOR SUCTION BCF50	TUBO DA EVAP. A COMPRESSORE				a
26	096008	0646R20000	EXPANSION VALVE -40/-56 ORIF.9	VALVOLA TERMOSTATICA	X			
27	095939	011008R010	INSULATION FOR THERMOS. VALVE	ISOLAMENTO VALVOLA TERMOSTAT.		X		Diam. 15
27	095938	0110067003	INSULATION FOR THERMOS. VALVE	ISOLAMENTO VALVOLA TERMOSTAT.		X		Diam. 35
28	087758	0805749401	TANIC RECEIVER 0.88L	RICEVITORE DI LIQ. A SALD. 0,88 L				a
29	087438	0805747600	DEHIDRATOR FILTER	FILTRO DCL083S 10MM	X	X		a
30	088351	0646749000	BOB.CLIP 10W EVR6 220-230/50-60	BOBINA VALVOLA SOLENOIDE	X	X		a
31	084085	0646723000	BODY SOLENOID VALVE	CORPO VALV. EVR 6	X	X		a
32	096005	0646R19201	SUCTION PROBE "GREEN"	SONDA ASPIRAZIONE VERDE	X	X		
33	096006	0646R19301	CONDENSER PROBE "BLACK"	SONDA CONDENSATORE NERA	X	X		
34	094256	0546R26200	RUBBER SUPPORT	PORTAGOMMA		X		
35	094257	0546R26900	NUT 1'1/2	GHIERA 1'1/2		X		
39	095961	0505R29301	BACK SPACER PROTECTION	DISTANZIALE /COPERTURA POST.		X		
40	095919	0835R61403	EVAPORATOR FOAMED PANEL BCF70	PANNELLO SCHIUMATO DI COPERT.				
41	096002	0640R04101	DOOR MICROSWITCH	MICRO PORTA	X			
42	096075	0832R09501	ASS. UV LAMP	ASSIME LAMPADA				
43	084384	0624705200	PLASTIC SPRING	MOLLE PE LAMPADA				
44	093097	0549R05400	GLASS UV	VETRO FRONTALE LAMPADA				
45	093945	0514R11900	PROTECTION	PROTEZIONE				
46	093946	0559R01800	FRONT GASKET	GUARNIZIONE LAMPADA				
47	093948	0665R01100	UV SUPPORT	SUPPORTO LAMPADA				
48	093949	0661R01100	UV LAMP	LAMPADA				

Pos	Code	Factory code	Description	Descrizione	V	W & T	S	Ref/notes
reference pag. 6-7								
49	096068	0639R19700	GEWISS BOX REMOTE	SCATOLA GEWISS REMOTO				b
50	096071	0639R20000	REMOTE CLAMP CONNECTIONS R.	MORSETTIERA SCATOLA REMOTA				b
51	095992	0617R18501	HEAT. EL. CABLE BCF 70KG L=5200MM	CAVO RISCALDANTE L=5200MM				
52	095983	0544R07600	PIPE PVC	TUBO PVC RIGIDO IRLHF Ø40				
53	095989	0569R10000	COIBENTATION PIPES	TUBO ANTICOND. GREY DIAM.16-36				
54	095929	0646R20600	MAGNETIC SENSOR UV LAMP	SENSORE MAGNETICO LAMP.UV				
55	095965	0514R26901	REAR PROTECTIVE GRID BCF70 JJ	GRIGLIA POSTERIORE				
*	096171	0147300900	AMERICAN CANVAS TAPE M50XMM48	NASTRO TELA PLAST. M50XMM48				X
*	095768	0147017034	PVILENE INSULATION TAPE; 50X3SP	NASTRO 3M389 NERO (MM19 X 50MT)				X

*= On demand

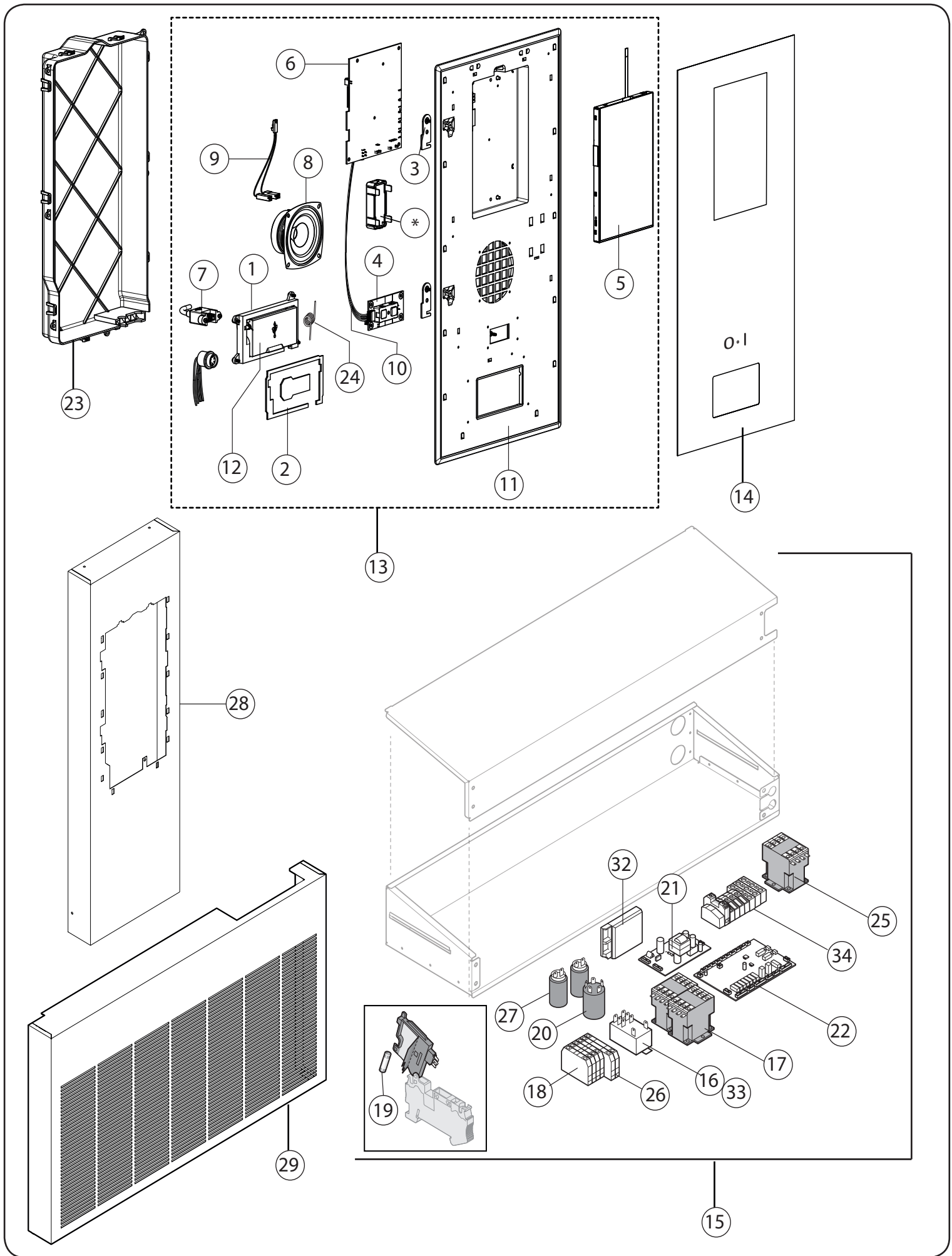

Pos	Code	Factory code	Description	Descrizione	V	W & T	S	Ref/notes
reference pag.10								
1	0CK030	0546400U01	DRAWER USB SUPPORT	CKM SEDE USB		X		
2	0CK031	0543401P02	GASKET DRAWER USB SUPPORT	GUARNIZIONE SEDE USB		X		
3		0506405M00	PANEL HOOK	GANCIO PANNELLO				
4	0CK033	0675401G00	ON/OFF BOARD	SCHEDA ON/OFF	X			
5	0CK034	0673400900	DISPLAY JDI 7"	DISPLAY JDI 7" TP RESISTIVO	X			
6	0CK036	0675401J01	BRIDGE BOARD	SCHEDA CONNESSIONE DISPLAY	X			
7	0CK037	0638404D00	WIRING USB	CAVO USB		X		
8	0CK039	0655400000	SPEAKER VISATON	ALTOPARLANTE		X		
9	0CK330	0675401L00	WIRING SPEAKER	CAVETTO CONNESSIONE SPEAKER		X		
10	0CK045	0675401Q00	WIRING ON/OFF BOARD	CAVETTO ON-OFF TOUCH	X	X		
11	0CK040	0543401N01	PLASTIC FRAME TOUCH	PANNELLO IN PLASTICA				
12	0CK041	0546400V01	USB COVER	SPORTELLINO USB ELUX		X		
13	0CK080	0830409103	ASS. TOUCH UI	PANNELLO COMPLETO UI				
14	095934	0755R13901	ADHESIVE DECOR A ELUX	MEMBRANA ADESIVE ELUX		X		order with n°11
14	095936	0755R16201	ADHESIVE DECOR A TOUCH APX	MEMBRANA ADESIVE APX		X		order with n°11
14	095935	0755R16101	ADHESIVE DECOR A TOUCH ZAN	MEMBRANA ADESIVE ZAN		X		order with n°11
14	096058	0541401V01	ADHESIVE DECOR A TO BRAND	MEMBRANA ADESIVE TO BRAND		X		order with n°11
15	096084	0882R86300	ELECTRICAL BOX COMPLETE UV	SCATOLA ELETTRICA COMPLETA				for uv lamp
15	096080	0882R19103	ELECTRICAL BOX COMPLETE	SCATOLA ELETTRICA COMPLETA				without uv lamp
15	096082	0882R72501	ELECTRICAL BOX COMPLETE REM	SCATOLA ELETTRICA COMPLETA REM				b
16	093848	0648R06300	RELAY 66.82.8.230.0001	RELE' FINDER	X	X		
17	088477	0648807300	CONTACTOR K3-10N 230V 50/60HZ	CONTATTORE K3-10N 230V 50/60HZ	X	X		a,b
18	096000	0639R18401	MAIN TERMINAL BLOCK	BLOCCHETTI DI CONNESSIONE ELET.				a
18	096070	0639R19900	MAIN TERMINAL BLOCK	BLOCCHETTI DI CONNESSIONE ELET.				b
19	095933	0652R02400	GLASS FUSE 10A T 5X20	FUSIBILE IN VETRO 10A T 5X20	X	X		
20	059078	0694502400	FILTRO LC 411524410D	FILTRO LC				for uv lamp
20	084987	0694700800	RFI FILTER 411.5.14.41.0 (TIPO L-C)	FILTRO ANTIDISTURBO		X		without uv lamp
21	095639	0648R10000	POWER SUPPLY 12V 30W	SCHEDA DI POTENZA 12V 30W	X			
22	096010	0648R08602	ACU PETRA BCF	SCHEDA PRINCIPALE "PETRA"	X			
23	0CK161	0541401D00	PROTECTION COMAND PANEL	PROTEZIONE PANNELLO COMANDI				
24	0CK032	0514405001	SPRING DOOR USB	MOLLA SPORTELLINO USB		X		
25	088477	0648807300	CONTACTOR K3-10N	CONTATTORE K3-10N 230V 50/60HZ				
26	093564	0639732800	FUSE SUPPORT	MORSETTO2 VIE X PORTAFUSIBILE				
27	090089	0648729500	FAN CAPACITOR 5 mF	CONDENS.B 5MFPER VENT. COND.				
28	095951	0503R62803	CONTROL PANEL BCF70	PANNELLO DI CONTROLLO SS				
29	095952	0503R65403	CONDENSER PANEL BCF70 ELUX	PANNELLO CONDENSATORE				ELUX
29	096050	0504R02700	CONDENSER PANEL BCF70 OTHER	PANNELLO CONDENSATORE				ALL
32	093950	0624R01600	ALIMENTAT. ELETTRON. UV	ALIMENTAT. ELETTRON. UV				for uv lamp
33	006610	0648806900	RELE'62.838.230.0009+ATT.BARRA	RELE' +ATT.BARRABARRA DIN OPP	X	X		b
34	095999	0639R18100	CLAMP POWER SIGNALS	MORSETTIERA POTENZA/SEGNALE				
34	096069	0639R19800	CLAMP POWER SIGNALS	MORSETTIERA POTENZA/SEGNALE				b

Spare Part Code KIT	Description KIT	Spare Part Code	Spare Part Q.ty	Spare part Description	Descrizione Spare part	Ref./ Note
---------------------	-----------------	-----------------	-----------------	------------------------	------------------------	------------

KIT DI MANUTENZIONE - MAINTENANCE KIT

096168	SKL BCF 70 PM KIT					
		095987	1	DOOR MAGNETIC GASKET BCF70	GUARNIZIONE PORTA	
		095939	2mt	INSULATION FOR THERMOS. VALVE	ISOLAMENTO VALVOLA TERMOSTAT.	Diam. 15
		095938	2mt	INSULATION FOR THERMOS. VALVE	ISOLAMENTO VALVOLA TERMOSTAT.	Diam. 35
		095989	1mt	COIBENTATION PIPES	TUBO ANTICOND. GREY DIAM.16-36	
		095165	1	CLIP OBO 255/3,2 OBO 255.3.2	FERMACAVO OBO 255/3,2 OBO 255.3.2	
		096156	5	SCREW 4,8X70/60 DIN 6928	VITE AUTOFIL. TE FLANG. ZINCATA 4,8X70/60 DIN 6928	