

DE GAS FRENCH TOP 10KW / 12.5KW
EN GAS FRENCH TOP 10KW / 12.5KW

PNC	Factory Model	Ref.	Description
588504	MBLIBBHOPO	a	GAS FRENCH TOP, C-Board, 800X850X250H
588684	MBLIGBHDPO	b	GAS FRENCH TOP WITH GN BOWL, C-Board, 800X850X700H
593118	MBLIBBHOVO	c	GAS FRENCH TOP, TOWNGAS, C-Board, 800X850X250H
593119	MBLIGBHDVO	d	GAS FRENCH TOP WITH GN BOWL, TOWNGAS, C-Board, 800X850X700H
589014	MCLIABJOPO	e	GAS FRENCH TOP, C-Board, 1000X900X250H
589580	MCLIAAJOPO	e	GAS FRENCH TOP, 1000X900X250H
589581	MCLIEAJDPO	f	GAS FRENCH TOP WITH GN BOWL, 1000X900X700H
589582	MCLIEBJDPO	f	GAS FRENCH TOP WITH GN BOWL, C-Board, 1000X900X700H
589583	MCLIFAJDPO	g	GAS FRENCH TOP WITH GN BOWL, 1000X900X800H
589584	MCLIFBJDPO	g	GAS FRENCH TOP WITH GN BOWL, C-Board, 1000X900X800H
593342	MCLIABJOVO	h	GAS FRENCH TOP, TOWNGAS, C-Board, 1000X900X250H
593343	MCLIAAJOVO	h	GAS FRENCH TOP, TOWNGAS, 1000X900X250H
593344	MCLIEAJDVO	i	GAS FRENCH TOP WITH GN BOWL, TOWNGAS, 1000X900X700H
593345	MCLIEBJDVO	i	GAS FRENCH TOP WITH GN BOWL, TOWNGAS, C-Board, 1000X900X700H
588690	MBVGGBHCPO	k	GAS FRENCH TOP ON STATIC OVEN, C-BOARD, 800X850X700H
593122	MBVGGBHCVO	k	GAS FRENCH TOP ON STATIC OVEN, TOWNGAS, C-BOARD, 800X850X700H
589637	MCVGEAJCPO	m	GAS FRENCH TOP ON STATIC OVEN, 1000X900X700H
589638	MCVGEBJCPO	m	GAS FRENCH TOP ON STATIC OVEN, C-BOARD, 1000X900X700H
593352	MCVGEAJCVO	m	GAS FRENCH TOP ON STATIC OVEN, TOWNGAS, 1000X900X700H
593353	MCVGEBJCVO	m	GAS FRENCH TOP ON STATIC OVEN, TOWNGAS, C-BOARD, 1000X900X700H
589639	MCVGF AJCPO	o	GAS FRENCH TOP ON STATIC OVEN, 1000X900X800H
589640	MCVGFBJCPO	o	GAS FRENCH TOP ON STATIC OVEN, C-BOARD, 1000X900X800H

Page	Index	Last Updates	Page	Ref.
2	Top	01/2015	all	
4	Mechanical module	02/2016	8/10/14/16	
6	Grease drawer	05/2016	14/16	
8	Gas line 10kW	09/2017	18, 19, 20	
10	Gas line 12.5kW	09/2017	11	6, 16, 34
12	Base			
14	Oven			
16	Base Oven			

Valid from Ser. N° 3101....

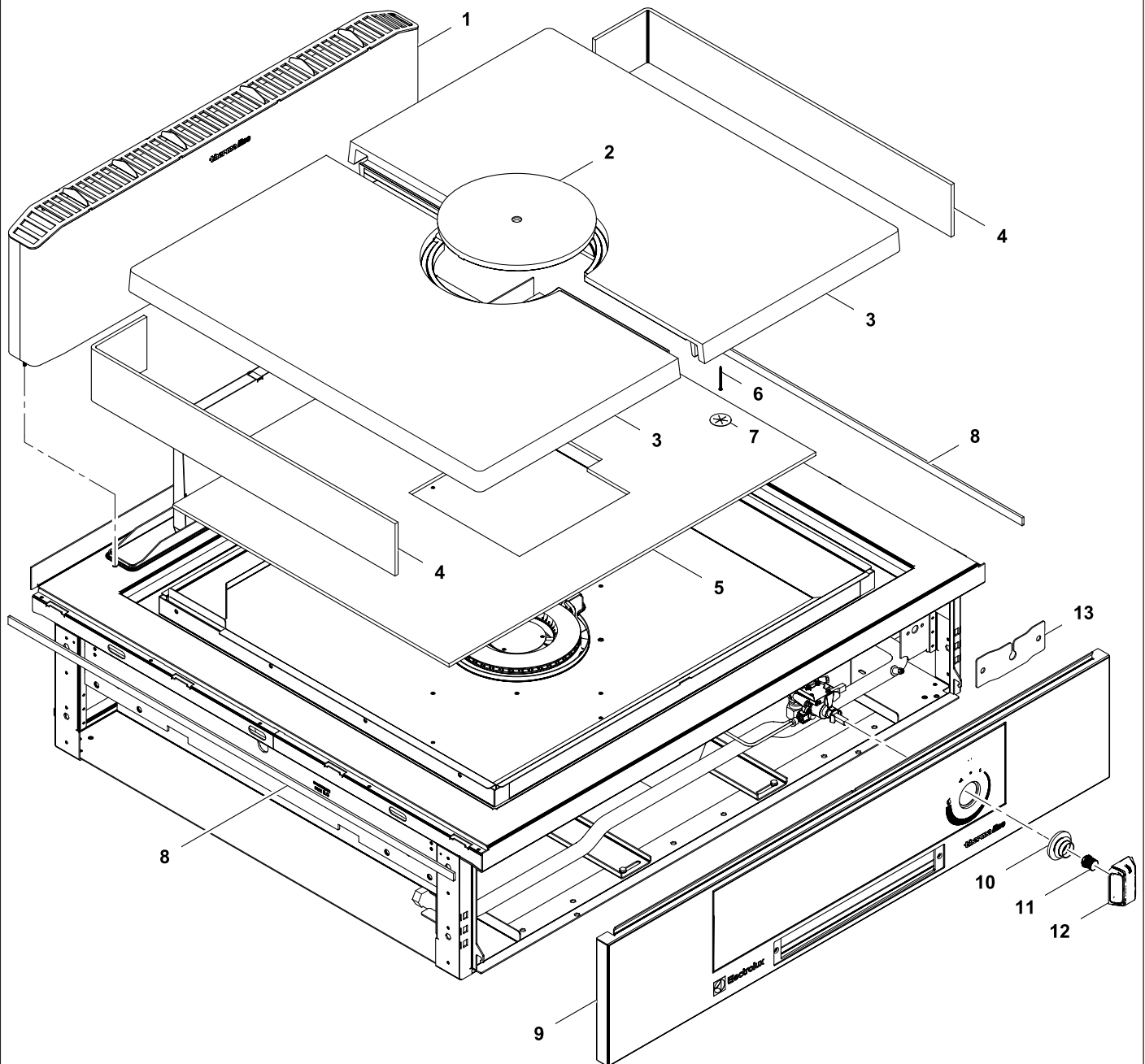

1	Alias	Code	Bezeichnung	Description	Ref.	Valid from Serial N°
1	82.4044.03		Kamin	Flue	all types	
2	-	026953	Mitteleinsatz	Center plate	W=1000	
	82.7285	050803	Mitteleinsatz	Center plate	W=800	
3	-	0C0787	Heizplatte links/rechts	Heating plate left/right	W=1000	
	82.7287		Heizplatte links	Heating plate left	W=800	
	82.7286		Heizplatte rechts	Heating plate right	W=800	
2+3	82.7419	OCA586	Heizplatte komplett	Heating plate complete	W=1000	
	82.7311	OCA587	Heizplatte komplett	Heating plate complete	W=800	
4	82.7425	0G7831	Isolation seitlich	Insulation for sides	W=1000	
	82.7299		Isolation seitlich	Insulation for sides	W=800	
5	82.7424	0G7832	Isolation Brennerkammer	Insulation bottom	W=1000	
	82.7298		Isolation Brennerkammer	Insulation bottom	W=800	
6	1 201 1959	0G6987	Isolationsnägel	Insulation nails	all types	
7	1 201 1961	0G4127	Isolationsclips	Insulation clips	all types	
8	82.7464	0C2496	Dichtung seitwärts	Sealing strip	all types	
9	82.1049.71		Bedienblende W=800 INOX	Control panel W=800 INOX	b d	
	82.1049.89		Bedienblende W=800 INOX Schublade	Control panel W=800 INOX Drawer	a c	
	82.1027.88		Bedienblende W=1000	Control panel W=1000	f g i	
	82.1027.87		Bedienblende W=1000 Schublade	Control panel W=1000 Drawer	e h	
	82.1000.07	0G7445	Blende W=1000 Rückseite	Back panel W=1000	no C-board	
10	82.7009	0G6247	Dichtung Drehgriff	Sealing for handle	all types	
11	82.7004.03	0G6727	Adapter Drehgriff	Adapter for handle	all types	
12	82.7002	0G6248	Drehgriff	Handle	all types	
13	82.4369		LED Halter	LED support	all types	

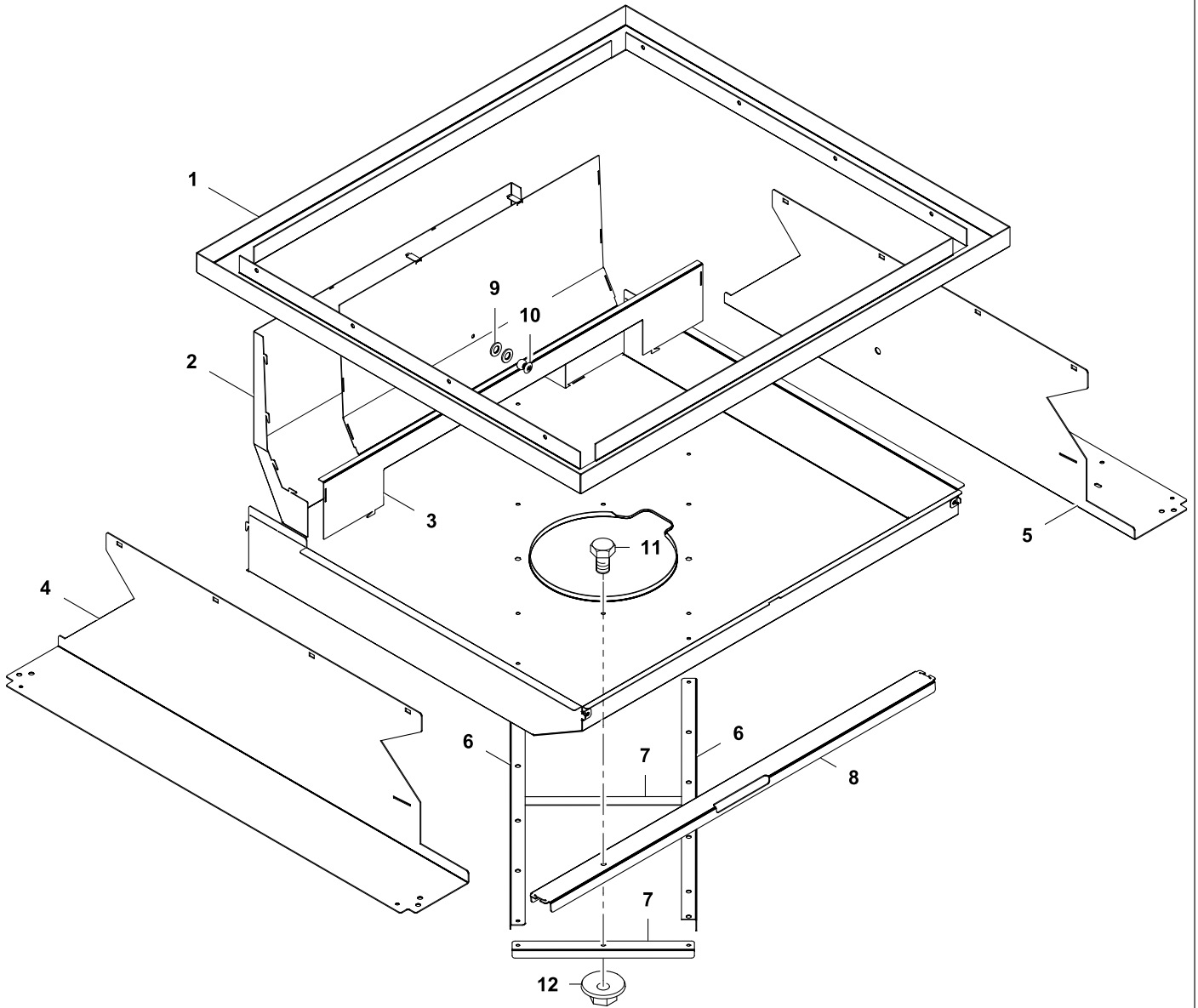

2	Alias	Code	Bezeichnung	Description	Ref.	Valid from Serial N°
1	82.4463.01		Ablaufrahmen	Drain frame	a,b,c,d	
	82.4464.01		Ablaufrahmen	Drain frame	e,f,g,h,i	
2	82.4295		Brennkammer	Combustion chamber	a,b,c,d	
	82.4424		Brennkammer	Combustion chamber	e,f,g,h,i	
3	82.4296		Abdeckung hinten	Back cover	a,b,c,d	
	82.4425		Abdeckung hinten	Back cover	e,f,g,h,i	
4	82.4299.01		Seitenplatte links	Side panel left	a,b,c,d	
	82.4299.02		Seitenplatte rechts	Side panel right	a,b,c,d	
5	82.4423.02		Seitenplatte links	Side panel left	e,f,g,h,i	
	82.4423.01		Seitenplatte rechts	Side panel right	e,f,g,h,i	
6	82.4426	*	Brennkammer Verstärkung	Combustion chamber reinforcement	e,f,g,h,i	
7	82.4427	*	Brennkammer Verstärkung	Combustion chamber reinforcement	e,f,g,h,i	
10	82.4306		Brenner Support Vorne	Burner support front	a,b,c,d	
	82.4440		Brenner Support Vorne	Burner support front	e,f,g,h,i	
11	1 701 3535	OG3588	U-Scheibe 5.3x10x1	U- Washer 5.3x10.1	a,b,c,d	
12	1 701 5075	OG7624	Niete 4.1	Rivet 4.1	a,b,c,d	
13	1 701 2569	OG3108	Schraube 6kt M6x16	Screw Keps 6kt M6x16	e,f,g,h,i	
14	712 044120.06	OG3997	Mutter Keps M6	Nut Keps M6	e,f,g,h,i	

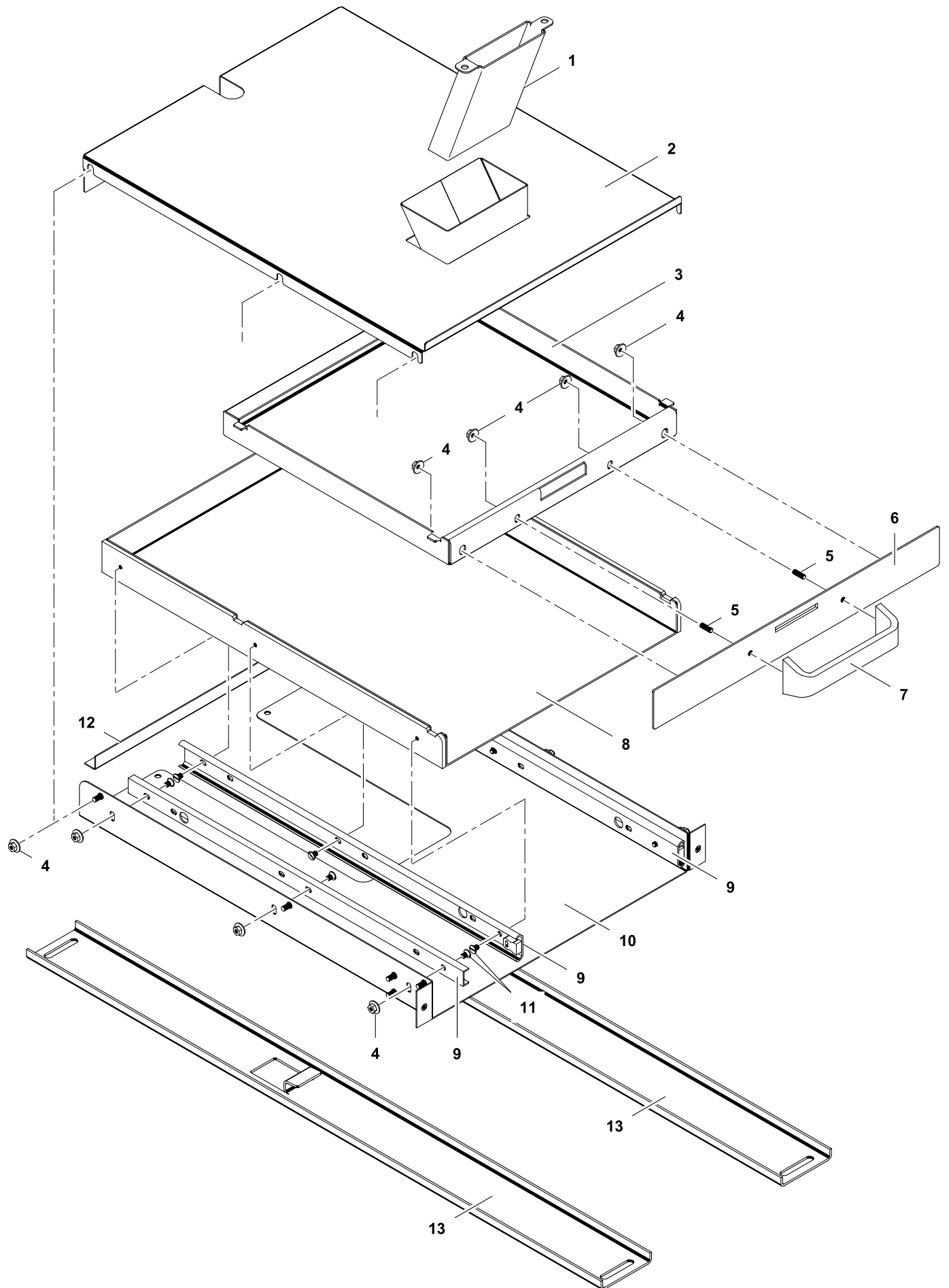

3	Alias	Code	Bezeichnung	Description	Ref.	Valid from Serial N°
1	82.2416.03		Ablauf in Schublade	Drain in drawer	all D850/H250	
	82.4436	OG7823	Ablauf in Schublade	Drain in drawer	all D900/H250	
2	82.4280.08		Schubladenabdeckung	Drawer cover	all H250	
3	82.4281.02	OG7031	Schubladeneinsatz	Drawer insert	all H250	
4	712 044120.04	OG4918	Keps-Mutter M4	Keps nut M4	all H250	
5	1 701 5532	OG7217	Gewindestift M4x12	Set screw M4x12	all H250	
6	82.2279	OG7032	Frontblech Schublade	Front panel drawer	all H250	
	82.2941		Frontblech Schublade	Front panel drawer	all H250	7011...
7	82.2209	OG7033	Griff	Handle	all H250	
8	82.4284.02	OG7030	Schubladenauszug	Drawer	all H250	
9	82.7201	OG6687	Führungsschiene	Rail	all H250	
10	82.4279	OG7034	Schubladenschacht	Drawer support	all H250	
	82.2942		Schubladenschacht	Drawer support	all H250	7011...
11	1 701 1145	OG6758	Senkkopfschraube M4x6	Countersunk screw M4x6	all H250	
12	82.4373	OG7035	Verstärkung	Reinforcement	all H250	
	82.2944		Verstärkung	Reinforcement	all H250	7011...
13	82.6504.04	*	Aufhängung Schublade D850	Drawer guide D850	all D850/H250	
	82.6504.05	*	Aufhängung Schublade D900	Drawer guide D900	all D900/H250	

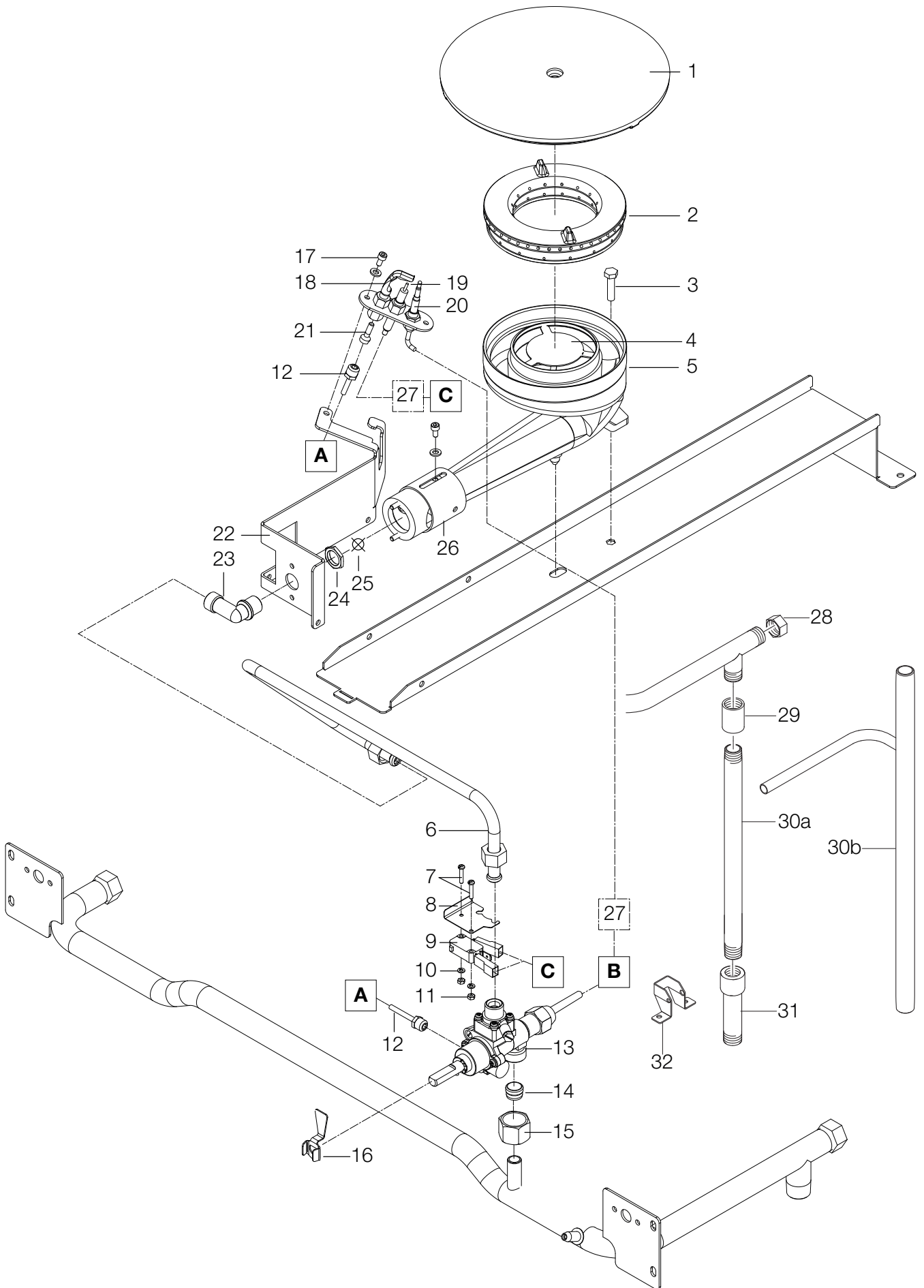

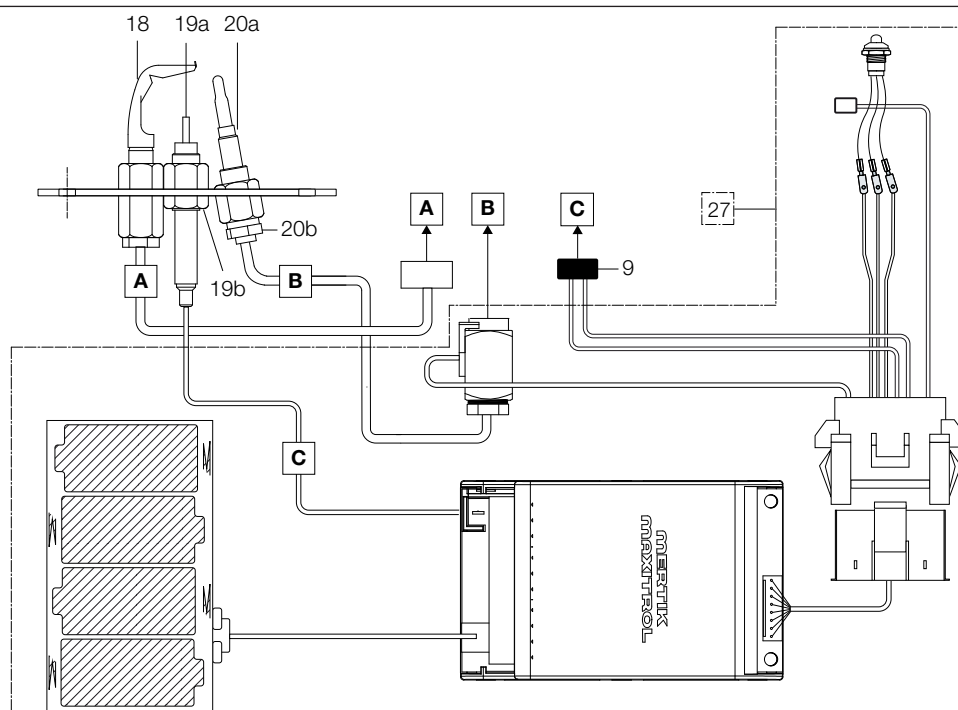

4	Alias	Code	Bezeichnung	Description	Ref.	Valid from Serial N°
1	82.7285	050803	Mitteleinsatz	Center plate	all 10kW	
2	82.7289	004280	Brennerdeckel	Burner lid	all 10kW	
3	1 701 2509	OK4598	Schraube M5x12	Screw M5x12	all 10kW	
4	82.4310		Brennerblech	Burner cover	all 10kW	
5	82.7288	004279	Brenner 10kW	Burner 10kW	all 10kW	
6	82.7291		Gaszuleitung Brenner	Gasline burner	all 10kW	
7	1 701 1087	OG6797	Schraube M3x16	Screw M3x16	all 10kW	
8	82.4068	OG6944	Stütze Mikroschalter	Microswitch support	all 10kW	
	82.4678	OG7909	Stütze Mikroschalter	Microswitch support	all 10kW	7031...
9	82.7156	053671	Mikroschalter	Microswitch	all 10kW	
10	1 701 5068	OKW901	Federring M3	Spring washer M3	all 10kW	
11	1 701 3057	OU0182	Mutter M3	Nut M3	all 10kW	
12	82.7292		Gaszuleitung Zündbrenner	Gasline Ignition burner	all 10kW	
13	82.7040	OC8647	Gashahn Pintossi 22S	Gas valve Pintossi 22S	all 10kW	
	712 344996		Gashahn Towngas	Gas valve Towngas	Towngas D850	
14	712 345053.01	OG3333	Klemmring	Clamp ring	all 10kW	
15	712 345052.03	OKX142	Überwurfmutter	Sleeve nut	all 10kW	
16	82.4075		Hebel Mikroschalter	Microswitch lever	all 10kW	
	82.4679.01	OG7910	Hebel Mikroschalter	Microswitch lever	all 10kW	7031...
	82.4679.02	OG7911	Hebel Mikroschalter	Microswitch lever	Towngas D850	7031...
17	1 701 2629	OG5854	Schraube M4x12	Screw M4x12	all 10kW	
	1 701 3502	OG3595	Unterlegscheibe M4	Washer M4	all 10kW	
18	1 106 1224		Zündbrenner	Ignition burner	all 10kW	
19a	72.7820	059380	Zündeletrode	Ignition electrode	all 10kW	
19b	72.7759	057960	Anschluss Elektrode	Connection electrode	all 10kW	
20a	712 344970	020094	Thermoelement	Thermocouple	all 10kW	
20b	1 106 1236	OC0121	Thermoelementschraube	Thermocouple screw	all 10kW	
21	See nozzle list	-	Zündbrennerdüse	Ignition nozzle	all 10kW	
22	82.4297	82.4297	Halter Zündbrenner	Ignition burner support	all 10kW	
23	72.7102	OG3635	Düsenträger	Nozzle holder	all 10kW	
24	72.7748	020997	Gegenmutter zu Düse	Counter nut	all 10kW	
25	See nozzle list	-	Hauptbrennerdüse	Main burner nozzle	all 10kW	
26	82.7284	052116	Buchse	Airation pipe	all 10kW	
27	82.7332	OG6589	Kit Gassteuerung Mertik	Kit gas control Mertik	all 10kW	
28	1 102 2420	OKX259	Gewindekappe	End cap	all 10kW	
29	712 344852.24	OG6841	Gewindemuffe G1/2" x 34	Turnbuckle G1/2" x 34	all 10kW	
30a	82.7154		Doppelnippel L500 1/2"	Double nipple L500 1/2"	all 10kW	
30b	82.4623		Gasrampe French Top auf Ofen 800	Gasline French Top on Oven 800	k	
31	1 102 2397	OG3621	Rohrverlängerung G1/2"	Pipe extension G1/2"	all 10kW	
32	82.4676.01		Halter Gasrohr	Gas pipe Support	all 10kW	

* Components on demand
* Teile auf Anfrage

Doc. № 82.8121.03

Page: 9

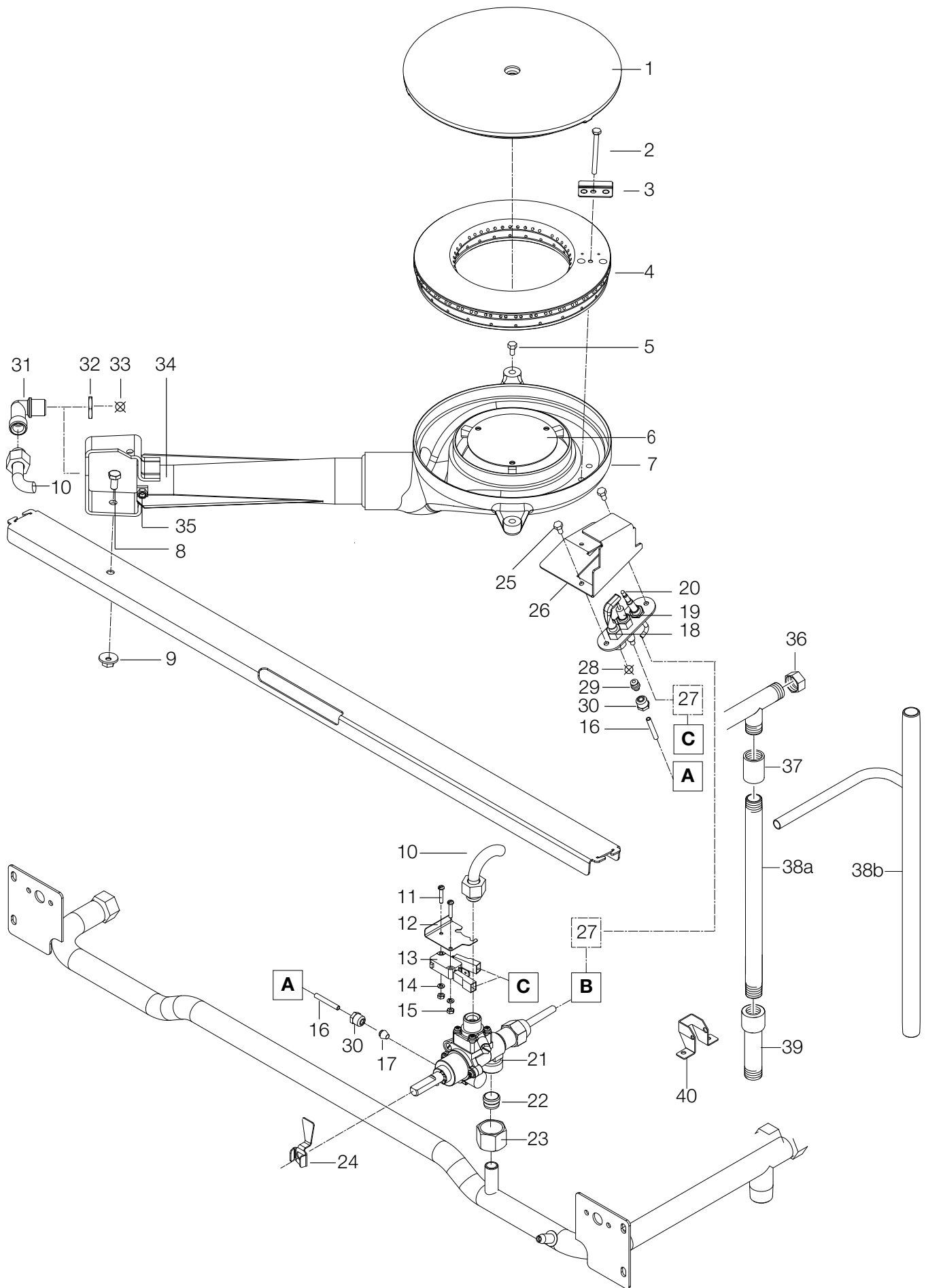

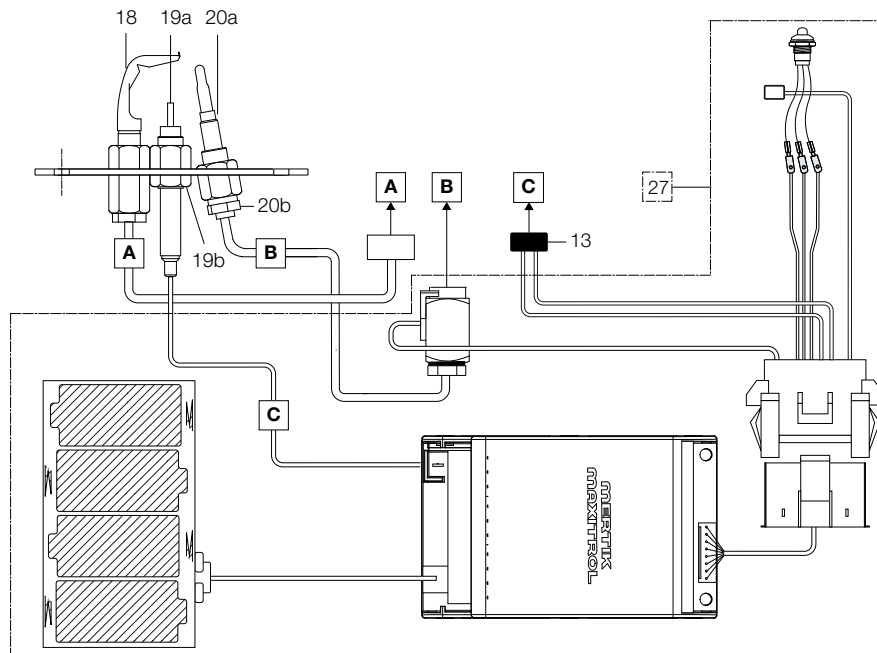

5	Alias	Code	Bezeichnung	Description	Ref.	Valid from Serial N°
1		026953	Mitteinsatz	Center plate	all 12,5 kW	
2			Schraube	Screw	all 12,5 kW	
3	82.4429		Brennerblech	Burner plate	all 12,5 kW	
4	82.7423	052377	Brennerdeckel	Burner lid	all 12,5 kW	
5			Schraube	Screw	all 12,5 kW	
6	82.4428	0G8041	Brennerblech rund	Burner cover	all 12,5 kW	
7	82.7422	059374	Brenner 12,5kW	Burner 12,5kW	all 12,5 kW	
8	1 701 2569	0G3108	Schraube M6x16		all 12,5 kW	
9	712 044120.06	0G3997	Kepsmutter M6		all 12,5 kW	
10	82.7427		Gaszuleitung Brenner	Gasline burner	all 12,5 kW	
11	1 701 1087	0G6797	Schraube M3x16	Screw M3x16	all 12,5 kW	
12	82.4068	0G6944	Stütze Mikroschalter	Microswitch support	all 12,5 kW	
	82.4678	0G7909	Stütze Mikroschalter	Microswitch support	all 12,5kW	7031...
13	82.7156	053671	Mikroschalter	Microswitch	all 12,5 kW	
14	1 701 5068	0KW901	Federring M3	Spring washer M3	all 12,5 kW	
15	1 701 3057	0U0182	Mutter M3	Nut M3	all 12,5 kW	
16	82.7428	0G8042	Gaszuleitung Zündbrenner	Gasline Ignition burner	all 12,5 kW	
17	1 701 2757	0G2960	Klemmring D4		all 12,5 kW	
18	1 106 1224		Zündbrenner	Ignition burner	all 12,5 kW	
19a	72.7820	059380	Zündelektrode	Ignition electrode	all 12,5 kW	
19b	72.7759	057960	Anschluss Elektrode	Connection electrode	all 12,5 kW	
20a	712 344970	020094	Thermoelement	Thermocouple	all 12,5 kW	
20b	1 106 1236	0C0121	Thermoelementschraube	Thermocouple screw	all 12,5 kW	
21	82.7040	0C8647	Gashahn Pintossi 22	Gas valve Pintossi 22	all 12,5 kW	
	712 344996	0K5756	Gashahn Towngas	Gas valve Towngas	Towngas D900	
22	712 345053.01	0G3333	Progressivring	Progressive ring	all 12,5 kW	
23	712 345052.03	0KX142	Überwurfmutter	Sleeve nut	all 12,5 kW	
24	82.4075		Hebel Mikroschalter	Mircoswitch lever	all 12,5 kW	
	82.4679.01	0G7910	Hebel Mikroschalter	Mircoswitch lever	all 12,5kW	7031...
	82.4679.02	0G7911	Hebel Mikroschalter	Mircoswitch lever	Towngas D900	7031...
25			Schraube	Screw	all 12,5 kW	
26	82.4433		Halter Zündbrenner	Ignition burner support	all 12,5 kW	
27	82.7332	0G6589	Kit Gassteuerung Mertik	Kit gas control Mertik	all 12,5 kW	
28	See nozzle list	-	Zündbrennerdüse	Ignition nozzle	all 12,5 kW	
29	72.7799		Verbindungsstück	Connection	all 12,5 kW	
30	72.7742		Verbindung	Connection	all 12,5 kW	
31	72.7102	0G3635	Düsenträger	Nozzle holder	all 12,5 kW	
32	72.7748	020997	Gegenmutter	Counter nut	all 12,5 kW	
33	See nozzle list	-	Hauptbrennerdüse	Main burner nozzle	all 12,5 kW	
34	82.7430	051774	Mischrohr	Aeration pipe	all 12,5 kW	
35	1 701 2579	0G4020	Schraube M5x16	Screw M5x16	all 12,5 kW	
36	1 102 2420	0KX259	Gewindekappe	End cap	all 12,5 kW	
37	712 344852.24	0G6841	Gewindemuffe G1/2" x 34	Turnbuckle G1/2" x 34	all 12,5 kW	
38a	82.7154		Doppelnippel L500 1/2"	Double nipple L500 1/2"	all 12,5 kW	
38b	82.7443		Gasrampe French Top auf Ofen 1000	Gasline Frenchtop on Oven 1000	m, k	
39	1 102 2397	0G3621	Rohrverlängerung G1/2"	Pipe extension G1/2"	all 12,5 kW	
40	82.4676.01		Halter Gasrohr	Gas pipe Support	all 12,5 kW	

* Components on demand
* Teile auf Anfrage

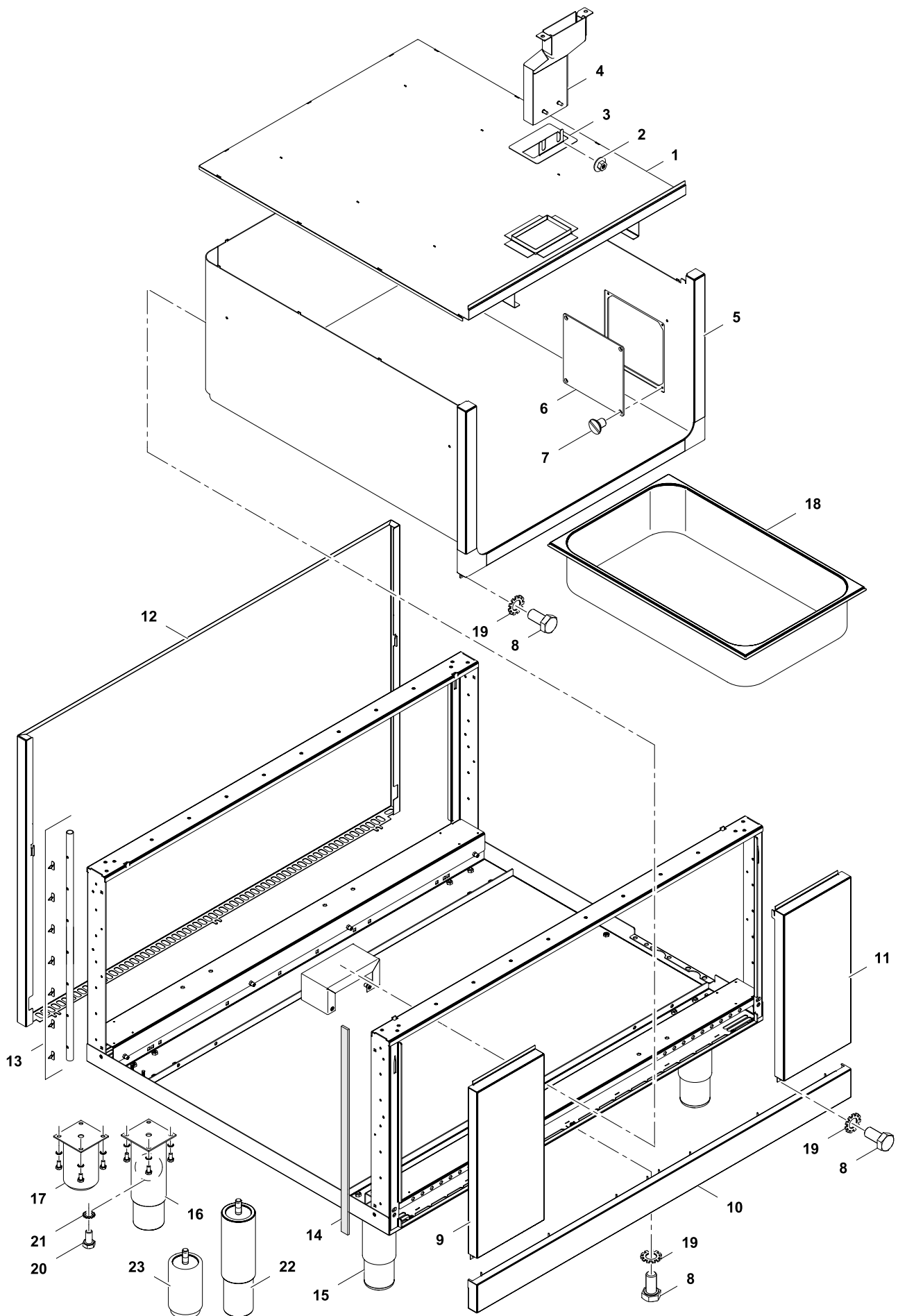

6	Alias	Code	Bezeichnung	Description	Ref.	Valid from Serial N°
1	82.0101.14	*	Deckel zu Korpus	Cover to corpus	b d f g i	
2	712 044120.05	OG3998	Kepsmutter M5	Keps nut M5	b d f g i	
3	82.0738		Spritzschutzdeckel fuer Ablauf	Splash guard for drain	b d f g i	
4	82.4439		Ablauf	Drain	f g i	
	82.2416.02		Ablauf in Korpus	Drain into corpus	b d	
5	82.0220.14		Korpus	Corpus	g	
	82.0220.11	OG7046	Korpus	Corpus	f g i	
	82.2436.09	OG7047	Korpus	Corpus	b d	
6	82.0223	OG6757	Deckel	Cover	b d f g i	
7	1 701 1145	OG6758	Senkschraube M4x6	Countersunk screw M4x6	b d f g i	
8	1 701 2579	OG4020	Schraube M5x16	Screw M5x16	b d f g i	
9	82.1042.04		Korpusabdeckung Links	Corpus cover Left	f g i	
10	82.1140.10	OG7901	Anschlussdeckel	Connection cover	f i	
	82.1140.08	OG7288	Anschlussdeckel	Connection cover	b d	
	82.1140.30	OG7792	Anschlussdeckel	Connection cover	g	
11	82.1041.04		Korpusabdeckung Rechts	Corpus cover right	f g i	
12	82.1102.07	OG7286	Rückwand OS 800x700	Back Panel OS 800x700	b d	
	82.1102.09		Rückwand OS 1000x700	Back Panel OS 1000x700	f i	
	82.1102.29		Rückwand OS 1000x800	Back Panel OS 1000x800	g	
13	82.7334	OG6396	Dichtung Geräte seitwaerts NM	Side-sealing strip NM	b d f g i	
14	82.7464	OC2496	Dichtband	Sealing tape	b d f g i	
15	83.3728	OG6886	Fuss 2" Marine 145/252mm	Adjustable feet 2" Marine145/252mm	b d f g i	
16	86.0001	OG5391	Fuss 2" 145/252mm Rund	Adjustable feet 2" 145/252mm round	b d f i	
17	86.2385	OG6140	Stellfuss 2" 100mm	Adjustable feet 2" 100mm	g	
18	1 110 1355	OS1733	GN 1/1-100	GN 1/1-100	b d f g i	
19	1 701 7002	OG2923	Faecher M5	Washer M5	b d f g i	
20	1 701 2600	OKT919	Schraube 6KT M6x12	Hex bolt M6x12	b d f g i	
21	1 701 5051	OG6753	Faecher M6	Washer M6	b d f g i	
22	82.0350.02		Fuss M10 100mm	Foot M10 100mm	g	7141...
23	82.0350.01		Fuss M10 200mm	Foot M10 200mm	b d f i	7141...

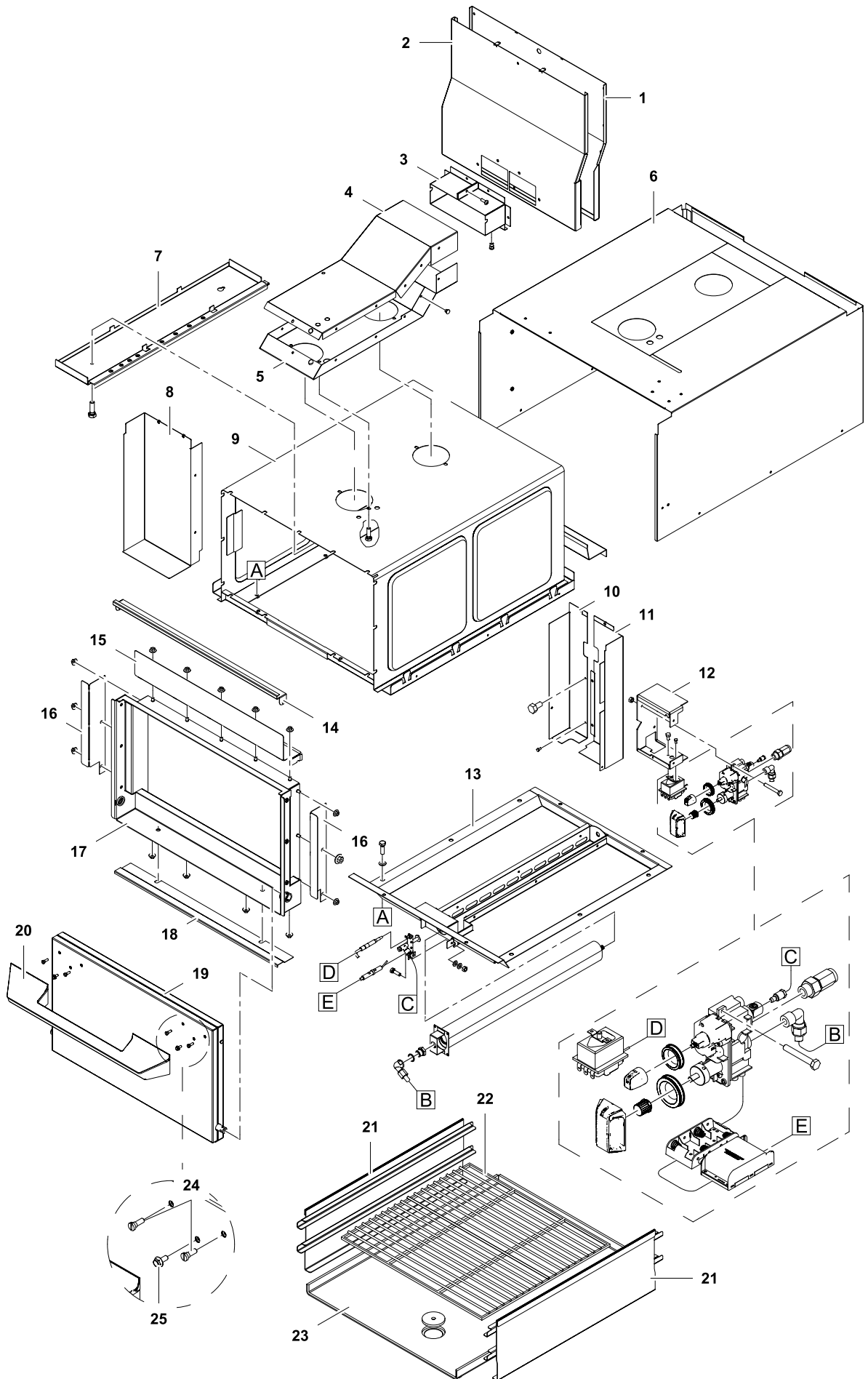

7	Alias	Code	Bezeichnung	Description	Ref.	Valid from Serial N°
1	82.4600	*	Kamin Rückwand	Chimney rear panel	k m o	
2	82.4599	*	Kamin Frontblech	Chimney front panel	k m o	
3	82.4598	*	Verbindung Kamin zu Abgaskanal	Connection chimney to flue	k m o	
4	82.4602	*	Abgaskanal Oberteil	Flue upper part	k m o	
5	82.4601	*	Abgaskanal Unterteil	Flue bottom part	k m o	
6	82.4639	*	Cover Ofen	Cover oven	k m o	
7	82.4591.01	*	Abdeckung Abgaskanal	Cover Flue	UL	
	82.4591.02	*	Abdeckung Abgaskanal	Cover Flue	k m o	
8	82.4647.02		Luftkanal links	Air channel left	m o	
	82.2776		Ventilationsbox links	Ventilation box left	k	
9	62.6201	*	Mantel Gasbackofen	Mantle Gas oven	k m o	
10	82.4596		Luftkanal rechts Teil 1	Air channel right part 1	m o	
	82.2777		Ventilationsbox rechts	Ventilation box right	k	
11	82.4597		Luftkanal recht Teil 2	Luftkanal rechts part 2	m o	
12	82.4266.01		Halter Mertik	Support Mertik	k	
	82.4266.02		Halter Mertik	Support Mertik	m o	
13	62.6211	*	Brennerwanne	Burner tub	k m o	
14	83.3048	*	Abdeckblech Frontrahmen	Covering plate frontal frame	k m o	
15	82.2309	*	Klemmblech oben	Clamping plate	k m o	
16	72.9822.02	*	Klemmblech seitlich	Clamping plate sideways	k m o	
17	83.3044	*	Frontrahmen Backofen	Frontal frame oven	k m o	
18	83.3047	*	Abdeckblech Frontrahmen unten	Covering plate frontal frame bottom	k m o	
19	83.3450	0G6666	Backofentür	Oven door	k m o	
20	82.6500	0G7224	Türgriff	Door handle	k m o	
21	62.6216	0G5670	Rostführung	Grill rail	k m o	
22	1 110 1300	0K6412	Grillrost 2/IGN	Grill 2/IGN	k m o	
23	62.5618		Einlegeplatte	Bottom plate	k m o	
24	82.7352	093923	Schlitzschraube M5x12	Slotted screw M5x12	k m o	
25	82.7567		Sicherungsschraube M5x16	Locking screw M5x16	k m o	

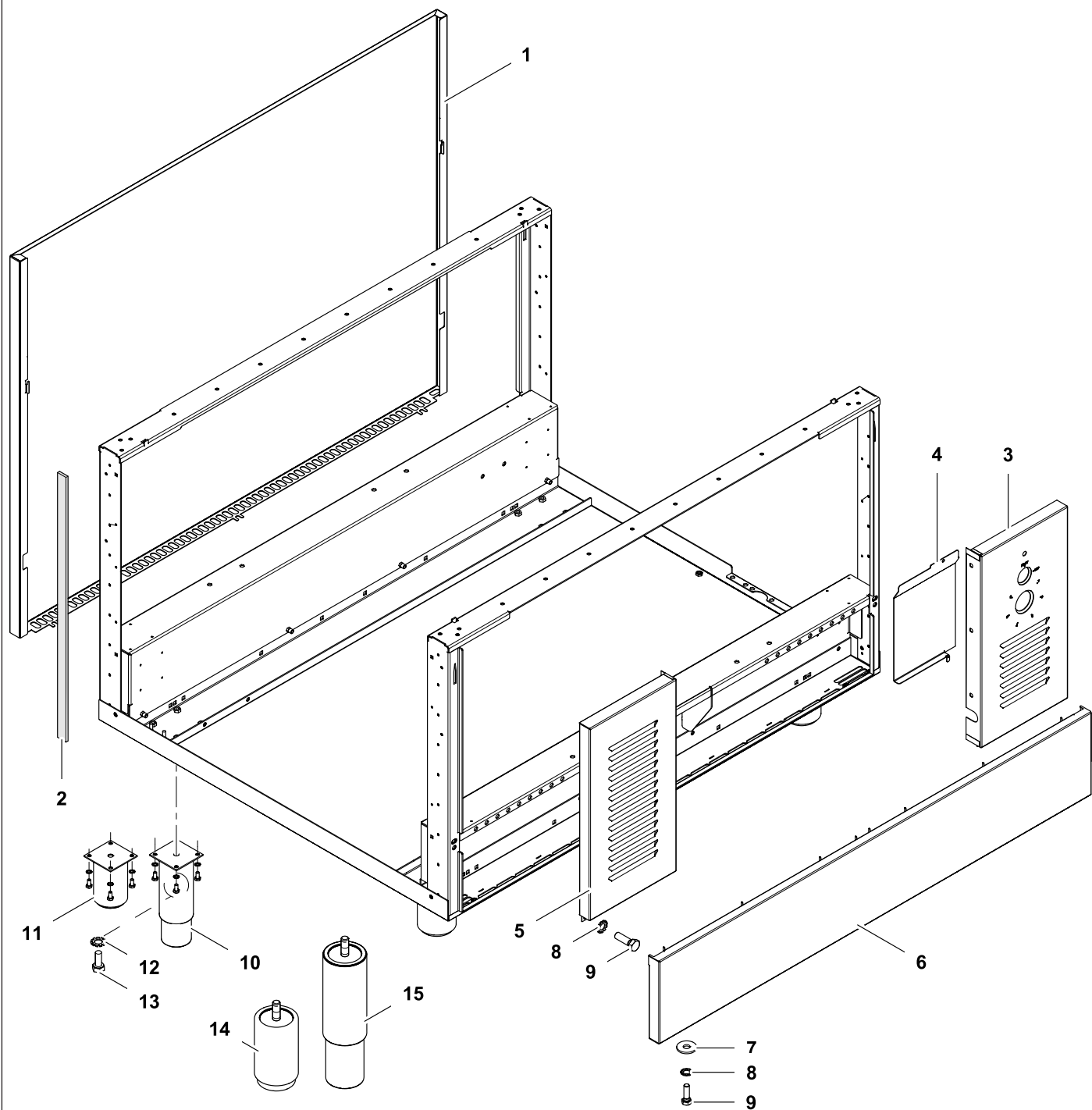

8	Alias	Code	Bezeichnung	Description	Ref.	Valid from Serial N°
1	82.1102.09	*	Rückwand 1000x700H	Rear panel 1000x700H	k m	
	82.1102.29	*	Rückwand 1000x800H	Rear panel 1000x800H	o	
2	82.7467	OC7307	Seitliche Dichtung	Sealing sideways	all types	
3	82.1149.01		Reglerblende Ofen 151mm (°C)	Control panel oven 151mm (°C)	k	
	82.1149.02		Reglerblende Ofen 201mm (°C)	Control panel oven 201mm (°C)	m o	
4	82.4625.01	*	Wasserschutzblech 800	Water protection plate 800	k	
	82.4625.02	*	Wasserschutzblech 1000	Water protection plate 1000	m o	
5	82.7465		Blende links 51mm links	Panel left 51mm	k	
	82.7453.07		Blende links 201mm	Panel left 201mm	m o	
6	82.1140.08	OG7288	Anschlussdeckel H66 / 800mm	Bottom front panel H66 / 800mm	k	
	82.1140.10		Anschlussdeckel H66 / 1000mm	Bottom front panel H66 / 1000mm	m	
	82.1140.30	OG7792	Anschlussdeckel H166 / 1000mm	Bottom front panel H166 / 1000mm	o	
7	1 701 3545	OKI298	U-Scheibe Ø6.4xØ18x1.6	Washer Ø6.4xØ18x1.6	all types	
8	1 701 7002	OG2923	Fächerscheibe M5	Fan washer M5	all types	
9	1 701 2579	OG4020	Schraube 6kt M5x16	Hex screw M5x16	all types	
10	86.0001	OG5391	Fuss 2" 200mm	Foot 2" 200mm	o	
11	86.2385	OG6140	Fuss 2" 100mm	Foot 2" 100mm	k m	
12	1 701 5051	OG6753	Fächerscheibe M6	Fan washer M6	all types	
13	1 701 2600	OKT919	Schraube 6kt M6x12	Hex screw M6x12	all types	
14	82.0350.02		Fuss M10 100mm	Foot M10 100mm	k m	7141...
15	82.0350.01		Fuss M10 200mm	Foot M10 200mm	o	7141...



Electrolux

thermaline 80 / 85 / 90 Nozzle list / Düsentabelle

Appliance:

FRENCH TOP

Nominal heat input :

10 kW

Town gas: max 10kW / min 2.2 kW

Factory Model

MBLXXXXPX

Range:

850

Doc N°

82.8121.04

Town Gas	GAS TYPE	COUNTRY	NOMINAL PRESS.	GAS TYPE Testigas	CATAGORY	Pressure Regulator ±1%	Nozzle main burner (Abb. 2)		Nozzle F ignition burner (Abb. 4)			Aeration adj. PILOT BURNER X (mm)	Aeration adj. MAIN BURNER D (mm) (Abb. 1)	Gas Consum.	Gas consumption L/min 956.5 mbar Baro / 20 °C Sursee Allmendstrasse				
							Type	mm	Alias N°	Spare Part N°	N°				Alias N°	Spare Part N°	Min.	Nominal value	Max.
Natural Gas	G 110	DK, SE	8	G110	1a	-	6.75	72.7801.68	-	75	72.7800.03	059381	-	5	2.58m³/h	41.91	44.11	46.92	
	G 120	SE		G120	1b	-	5.60	72.7801.56	-	75	72.7800.03	059381	-	5	2.29m³/h	37.43	39.40	41.37	
	3	Natural Gas H	AT, CH, DK, EE, ES, FI, GB, GR, IE, IT, LV, NO, PT, SE, SI, SK, BG, CZ, HR, LT, RO, TR, CZ	20	G20	2H	-	2.20	72.7801.09	0A2083	27	72.7800.02	059215	-	7	1.06 m³/h	17.05	17.94	18.84
	4				G25.1	2S	-	2.50	72.7801.18	059382	27	72.7800.02	059215	-	5	1.23 m³/h	19.73	20.77	21.81
	5	Natural Gas H		20	G20	2H	-	2.40	72.7801.16	0A2104	27	72.7800.02	059215	-	8	1.06 m³/h	17.05	17.94	18.84
	6	Natural Gas E	DE, LU, PL	20	G20	2E	-	2.40	72.7801.16	0A2104	27	72.7800.02	059215	-	8	1.06 m³/h	17.05	17.94	18.84
	7	Natural Gas H/L Pressure Couple	BE, FR	20/25	G20	2E+	-	2.40	72.7801.16	0A2104	27	72.7800.02	059215	-	8	1.06 m³/h	17.05	17.94	18.84
	8				G25	2L	-	2.45	72.7801.11	059980	27	72.7800.02	059215	-	7	1.23 m³/h	19.73	20.77	21.81
	9	Natural Gas L	NL	25	G25	2L	-	2.60	72.7801.26	002792	27	72.7800.02	059215	-	7	1.23 m³/h	19.83	20.87	21.91
	10	Natural Gas LL	DE	20	G25	2LL	-	1.45	82.7388.07	0G6605	14	72.7800.01	059216	-	24	0.78 Kg/h	6.40	6.74	7.07
11	Propan	CH, DE, FR, HU, NL	50	G31	3P	-	1.45	82.7388.07	0G6605	14	72.7800.01	059216	-	24	0.79 Kg/h	4.91	5.17	5.43	
12	Butan/Propan	CZ, CY, DK, EE, FI, HU, LV, LT, MT, NL, NO, SE, SI, SK, BG, HR, IS, RO, TR	30	G30/31	3BP	-	1.55	82.7388.09	0G6533	14	72.7800.01	059216	-	24	0.79 Kg/h	4.95	5.21	5.47	
13							1.35	82.7388.06	0G6604	14	72.7800.01	059216	-	24	0.79 Kg/h	4.85	5.11	5.36	
14	Butangas Propan Pressure Couple	BE, CH, ES, FR, GB, GR, IE, IT, PT, LT, SI, CZ, EE, LV, SK	28.30 / 37	G30/31	3+	-	0.75	712.345064.22	0KK127	14	72.7800.01	059216	-	24	0.79 Kg/h	4.95	5.21	5.47	
15							0.65	712.345064.18	0K5872	14	72.7800.01	059216	-	24	0.79 Kg/h	4.85	5.11	5.36	

Abb. 1



Abb. 2

Type 1)

72.7801.xx

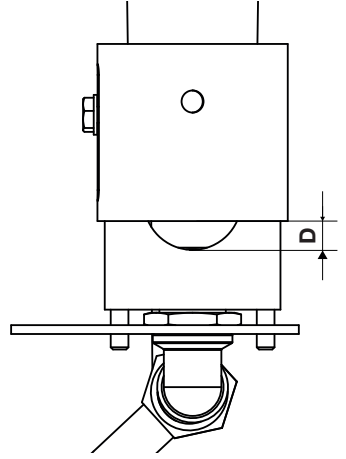
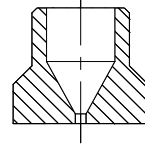

Type 2)

82.7388.xx



Abb. 3



Abb. 4



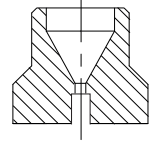
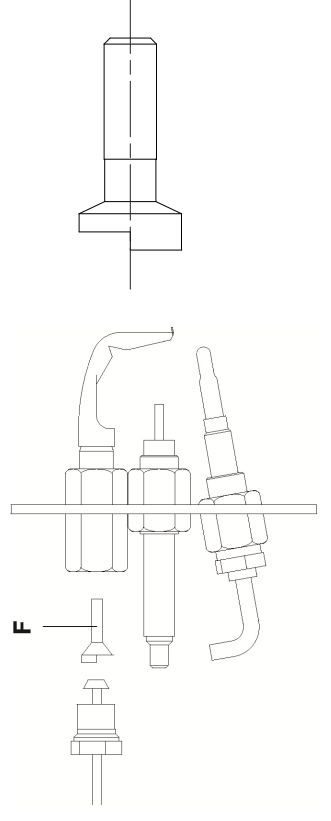

Electrolux

thermaline 80 / 85 / 90 Nozzle list / Düsentabelle

Appliance:

FRENCH TOP

Nominal heat input :

12,5 kW

Town gas: max10kW / min3.5 kW

Factory Model

MCLXXXXPX

Range:

900

Doc N°

82.8121.04

Town Gas	GAS TYPE	COUNTRY	NOMINAL PRESS.	GAS TYPE <small>Testigas</small>	CATEGORY	Pressure Regulator $\pm 1\%$	Nozzle main burner (Abb. 2)			Small adjusting nozzle (Abb. 3)			Nozzle F ignition burner (Abb. 4)			Aeration adj. PILOT BURNER X (mm)	Aeration adj. MAIN BURNER D (mm) (Abb. 1)	Gas Consum.	Gas consumption Lt/min 956.5 mbar Baro / 20°C Sursee Allmendstrasse	
							Type	mm	Alias N°	Spare Part N°	mm	Alias N°	Spare Part N°	N°	Alias N°				Spare Part N°	Min.
1	G 110	DK, SE	8	G110	1a	-	6.75	72.7801.68	-	Adjust.	unscrew 2 turn	75	72.7800.03	059381	-	10	2.56m³/h	41.91	44.11	46.32
3	Natural Gas H	HU	25	G20	2H	-	2.55	72.7801.41	059529	1.80	712.345064.36	OG4112	72.7800.02	059215	-	14	1.33 m³/h	21.31	22.43	23.55
4				G25.1	2S	-	2.80	72.7801.49	059383	2.00	712.345064.34	0T2203	72.7800.02	059215	-	14	1.54 m³/h	24.66	25.96	27.26
5	Natural Gas H	AT, CH, DK, EE, ES, FI, GB, GR, IE, IT, LV, NO, PT, SE, SI, SK, BG, CZ, HR, LT, RO, TR, CZ	20	G20	2H	-	2.65	72.7801.32	0A2174	1.80	712.345064.36	OG4112	72.7800.02	059215	-	14	1.33 m³/h	21.31	22.43	23.55
6	Natural Gas E	DE, LU, PL	20	G20	2E	-	2.65	72.7801.32	0A2174	1.80	712.345064.36	OG4112	72.7800.02	059215	-	14	1.33 m³/h	21.31	22.43	23.55
7	Natural Gas H/L Pressure Couple	BE, FR	20/25	G20	2E+	-	2.65	72.7801.32	0A2174	1.80	712.345064.36	OG4112	72.7800.02	059215	-	14	1.33 m³/h	21.31	22.43	23.55
8	Natural Gas L	NL	25	G25	2L	-	2.75	72.7801.48	0A2868	2.00	712.345064.34	0T2203	72.7800.02	059215	-	14	1.54 m³/h	24.66	25.96	27.26
9	Natural Gas LL	DE	20	G25	2LL	-	2.95	72.7801.50	006470	2.00	712.345064.34	0T2203	72.7800.02	059215	-	14	1.54 m³/h	24.78	26.09	27.39
11	Propan	CH, DE, FR, HU, NL	50	G31	3P	-	1.65	82.7388.13	-	0.95	712.345064.41	002392	72.7800.01	059216	-	12	0.98 Kg/h	8.00	8.42	8.84
12	Butan/Propan	CZ, CY, DK, EE, FI, HU, LV, LT, MT, NL, NO, SE, SI, SK, BG, HR, IS, RO, TR	30	G30/31	3B/P	-	1.70	82.7388.11	059336	1.10	712.345064.39	OG6598	72.7800.01	059216	-	12	0.99 Kg/h	6.19	6.51	6.84
14							1.55	82.7388.09	0G6533	0.85	712.345064.26	OG4163	72.7800.01	059216	-	12	0.99 Kg/h	6.06	6.38	6.70
15	Butangas Propan Pressure Couple	BE, CH, ES, FR, GB, GR, IE, IT, PT, LT, SI, CZ, EE, LV, SK	28/30 / 37	G30/31	3+	-	1.70	82.7388.11	059336	1.10	712.345064.39	OG6598	72.7800.01	059216	-	12	0.99 Kg/h	6.19	6.51	6.84

Abb. 1



Abb. 2



Abb. 3

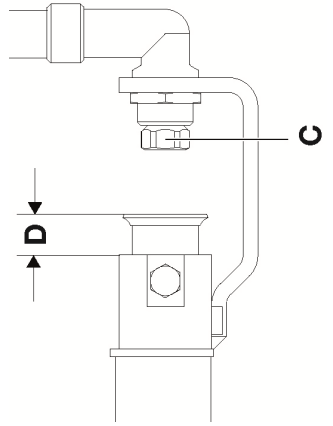

Abb. 4



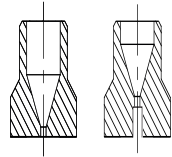

Electrolux

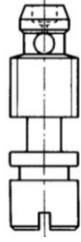
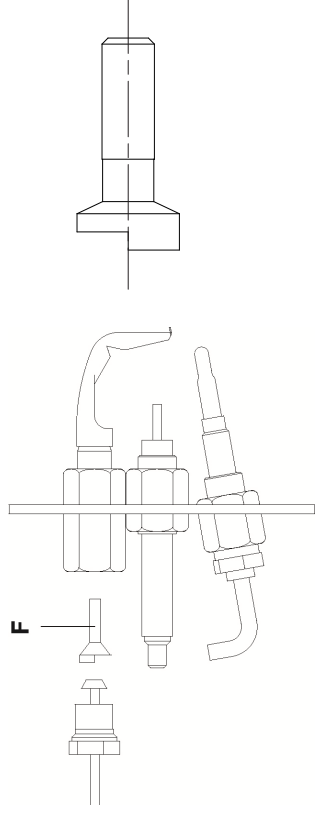
thermaline 80 / 85 / 90 Nozzle list / Düsentabelle

Appliance:

Nominal heat input :

7 kW

Factory Model

MXXXXXXCP/WX

Range:

800 / 850 / 900 82.8131.04

Doc N°

Gas Type	GAS TYPE	NOMINAL PRESS.	COUNTRY	GAS TYPE	CATEGORIES	Pressure Regulator ±1%	Nozzle C main burner (Abb. 2)		Small adjusting nozzle (Abb. 3)		Nozzle F ignition burner (Abb. 4)		Aeration adj. MAIN BURNER D (mm) (Abb. 1)		Spoiler sheet (Abb. 1)		Gas consumption		
							Type	mm	mm	mm	N°	Alias N°	Spare Part N°	D (mm)	Alias N°	Spare Part N°	Min.	Nominal value	Max.
Town Gas	G 110	8	DK, SE	G110	1a	-	4.10	72.5080.05	-	-	60	712.345056.04	0G4110	4.5	72.6824.01	1.81 m³/h	29.70	31.27	32.83
	G 120				1b	-	3.80	72.5080.06	0G6600	4.5	72.6824.01	1.61 m³/h	26.43	27.82	29.21				
	Natural Gas	G 20	25	HU	G20	2H	-	1.90	72.5080.01	0G2776	1.30	62.2500.09	0G2771	4.5	72.6824.01	0.74 m³/h	11.93	12.56	13.19
		G 25.1				2S	-	2.15	72.5080.02	0G3421	1.30	62.2500.09	0G2771	4.5	72.6824.01	0.86 m³/h	13.81	14.54	15.26
Natural Gas	Natural Gas H	20	AT, CH, DK, EE, ES, FI, GB, GR, IE, IT, LV, NO, PT, SE, SI, SK, BG, CZ, HR, LT, RO, TR, CZ	G20	2H	-	2.00	72.5080.01	0G2776	1.30	62.2500.09	0G2771	4.5	72.6824.01	0.74 m³/h	11.93	12.56	13.19	
					2E	-	2.00	72.5080.01	0G2776	1.30	62.2500.09	0G2771	4.5	72.6824.01	0.74 m³/h	11.93	12.56	13.19	
	Natural Gas E	20	DE, LU, PL	G20	2E	-	2.00	72.5080.01	0G2776	1.30	62.2500.09	0G2771	4.5	72.6824.01	0.86 m³/h	13.81	14.54	15.26	
					2E+	-	2.00	72.5080.01	0G2776	1.30	62.2500.09	0G2771	4.5	72.6824.01	0.86 m³/h	13.88	14.61	15.34	
	Natural Gas L	25	NL	G25	2L	-	2.10	72.5080.02	0G3421	1.30	62.2500.09	0G2771	4.5	72.6824.01	0.546 Kg/h	4.48	4.72	4.95	
					2LL	-	2.25	72.5080.15	-	1.30	62.2500.09	0G2771	4.5	72.6824.01	0.553 Kg/h	3.44	3.62	3.80	
Natural Gas LL	50	CH, DE, FR, HU, NL	G31	3P	-	1.30	72.5080.03	0G2777	0.70	62.2500.12	0G4641	8.5	72.6824.02	0.553 Kg/h	3.47	3.65	3.83		
				3B/P	-	1.30	72.5080.03	0G2777	0.80	62.2500.02	0G4808	8.5	72.6824.02	0.553 Kg/h	3.40	3.57	3.75		
Liquid Gas	Butan/Propan	30	CZ, CY, DK, EE, FI, HU, LV, LT, MT, NL, NO, SE, SI, SK, BG, HR, IS, RO, TR	G30/31	3B/P	-	1.40	72.5080.17	0G5767	0.80	62.2500.02	0G4808	8.5	72.6824.02	0.553 Kg/h	3.47	3.65	3.83	
					3+	-	1.20	72.5080.08	0G4636	0.70	62.2500.12	0G4641	8.5	72.6824.02	0.553 Kg/h	3.40	3.57	3.75	
Butangas Propan Pressure Couple	28.30 / 37	BE, CH, ES, FR, GB, GR, IE, IT, PT, LT, SI, CZ, EE, LV, SK	G30/31	3+	-	1.40	72.5080.17	0G5767	0.80	62.2500.02	0G4808	8.5	72.6824.02	0.553 Kg/h	3.47	3.65	3.83		

Abb. 1



Abb. 2



Abb. 3

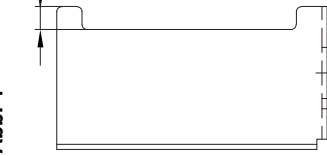

Abb. 4

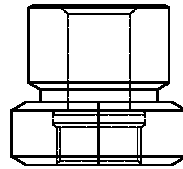
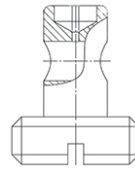