

A: : 9HH5 HF 79 ; F5J"
.....; **F5J+IMG@79F**.....

PNC	MODEL
601135	MAX 350

Pag.	Indice	Index
2	Disegni	Drawings
3	Lista ricambi	Spare parts list

Brand / Marchio: ELECTROLUX / DITO SAMA

FIGURE 1: BLADE ASSEMBLY - GAUGE PLATE - BASE - DEFLECTOR

No	DESCRIPTION	Q.	PART #	NOTE
1	KNOB VB50 LOKING COVER BLADE	1	202V007	
1	TUBE DRIVE MICROSWITCH	1	202V007	
2	COVER BLADE SHAFT	1	4101480	
3	TUBE LOCK ASSEMBLY BLADE SUPPORT	1	406AA16	
4	SPACER	1	700207K	
5	O-RING	1	3030508	
6	SHAFT BLADE SUPPORT	1	AVAILABLE WITHIN THE GROUP 2020814	
7	GEAR Z.30 PLASTIC	1	4080221	
8	RUBBER	6	3030407	
9	HOUSING BLADE SUPPORT	1	AVAILABLE IN THE PART#4020510	
10	HOUSING COVER MOTOR	1	AVAILABLE IN THE PART#4020510	
11	SCREW TSPTC M6X70 STAINLESS STEEL	1	UNI6109 DIN963	
13	STUD M6X70	1	UNI5929 DIN916	
14	SEAL RING TC 60 85 10	1	3030216	
15	BLADE SUPPORT	1	AVAILABLE WITHIN THE GROUP 2020814	
16	KNOB VB30 LOKING SHARPENER	1	4090302	
17	SHAFT LOKING SHARPENER	1	4101013	
18	BUSHING SHAFT LOCKING SHARPENER	1	4101012	
19	BLADE GUARD	1	4020439	UNTIL S.N. 01174193
19	BLADE GUARD	1	4020841	FROM S.N. 01174194
20	GASKET BLADE	1	4090001V	
21	BLADE 350	1	3026111	
22	COVER BLADE	1	4020742	
23	SHAFT CENTERING COVER BLADE	1	4101064	
24	HANDLE	1	4101002	
25	SREEW TSPTC M4X12 STAINLESS STEEL	2	UNI6109 DIN963	
26	SREEW TSPTC M5X12 STAINLESS STEEL	4	UNI6109 DIN963	
27	BUSHING CENTERING COVER BLADE D. 34MM	1	4101068	
27	BUSHING CENTERING COVER BLADE D.25MM	1	4101539	
28	SPACER	1	410485	
29	SCREW TCEI M6X40	4	UIN5931 DIN912	
30	SEAL RING G 34 52 8	1	3030203	FOR BUSHING POS. D.EXT.34MM
30	SEAL RING G 25 52 7	1	3030223	FOR BUSHING POS. D.EXT.25MM
31	RING LOCKING D.47	1	UNI7437 DIN472	
32	BEARING 6204 2RS	1	AVAILABLE WITHIN THE GROUP 2020814	
33	RING LOCKING D.42	1	UNI7437 DIN472	
34	BEARING 6004 DDU	1	AVAILABLE WITHIN THE GROUP 2020814	
35	DEFLECTOR	1	405BC07	
36	HANDLE DEFLTCTOR STAINLEES STEEL	1	4101445	
37	GAUGE PLATE	1	4020791	UNTIL S.N. 01174193
37	GAUGE PLATE	1	4020845	FROM S.N. 01174194
38	STUD M8X25 45H	2	UNI4766 DIN 551	
39	WASHER M8	2	UNI6592	
40	NUT M8	2	UNI5588	
41	TAP	2	3040152	
42	GAUGE PLATE SUPPORT	1	2050000KIT	
43	SHAFT GAUGE PLATE SUPPORT	1	2050000KIT	
44	SCREW	2	UNI6592 DIN125-A	
45	GASKET SUPPORT GAUGLE PLATE	1	4090003	
46	INDEXING KNOB	1	4090104	
47	FEET	4	3030403	
48	START SWITCH	1	3040198EC	
49	STOP SWITCH	1	3040197EC	
50	LABEL START STOP	1	3039954	
001	COMPLETLY SUPPORTO BALDE	1	2020814	

FIGURE 1

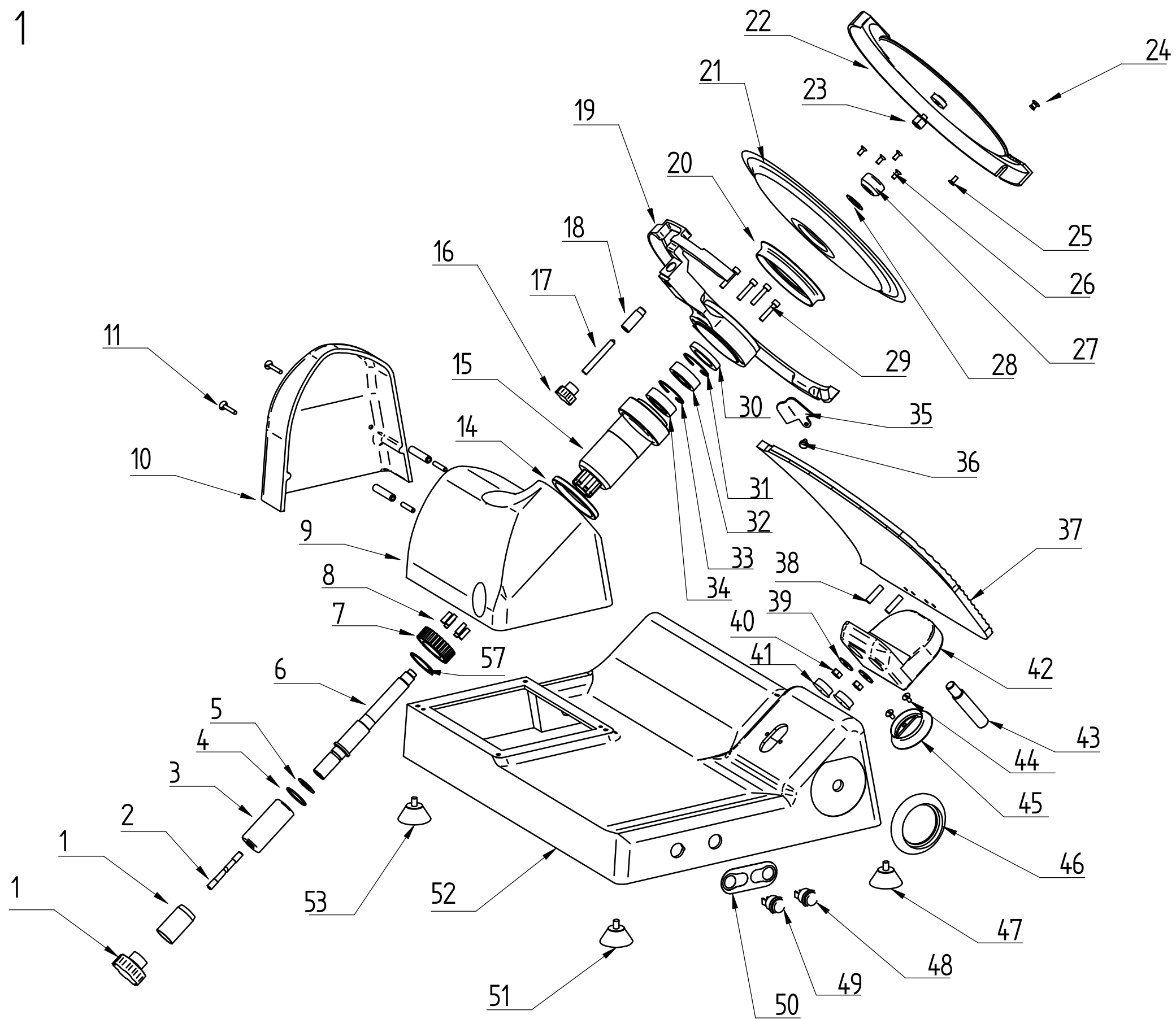

MODEL: NEW MAX 350- 370 CE (601135)
FIGURE 1: BLADE ASSEMBLY - GAUGE PLATE - BASE - DEFLECTOR
EDITION: 1° DATE 02-2017

FIGURE 2: COMPLETELY INDEXING KNOB - SUPPORT ARM - SUPPORT FENCE

No	DESCRIPTION	Q.	PART #	NOTE
1	SCREW TCEI M6X20	1	UNI 5931 DIN912	
2	RATCHET	1	405FC81	
3	SHAFT RATCHET	1	4101313	
4	PLASTIC TAP	1	4090327	
5	SPRING RATCHET	1	3031266	
6	ROUND BAR D.24	1	4070212	
7	SCREW TCEI M6X40	2	UNI 5931 DIN912	
8	RECTANGULAR BAR	1	4070308	
9	SCREW TCEI M6X20	3	UNI 5931 DIN912	
10	WASHER POLYURETHANE D.INT24X12	1	3030502	
17	CAMME	1	4090163	
18	NYLON WASHER	1	4101385	
19	BUSHING	1	4100066	
20	SPECIAL NUT	1	4100100	
21	INDEXING KNOB SHAFT	1	4100256	
22	SCREW D 4,2 X 13	2	AVAILABLE WITHIN THE GROUP 2V30012	
24	KNOB	1	AVAILABLE WITHIN THE GROUP 2V30012	
25	O-RING	1	AVAILABLE WITHIN THE GROUP 2V30012	
26	GRADUATED DISK	1	AVAILABLE WITHIN THE GROUP 2V30012	
27	STUD M5X16	1	UNI 5929 DIN 916	
28	STUD M5X6	1	UNI 5929 DIN 916	
29	FLAT SPRING 25 12,2 0,9	1	DIN 2093	
30	NYLON WASHER	1	4101385	
31	STUD M6X8	1	UNI 5929 DIN 916	
34	SUPPORT FENCE AJSTMENT	1	405CB32	
35	SCREW M6 x 16	1	UNI 5931 DIN 912	
36	SHAFT ,FENCE ADJUSTMENT	1	4100791	
37	SUPPORT FENCE	1	403E020	UNTIL A S.N. 12151922
37	SUPPORT FENCE	1	403E025	FROM S.N. 12151923
38	SPRING	1	3031236	
39	BUSHING	1	3030809	
40	BUSHING	1	3030809	
41	ROLLER	1	4100525	
42	WASHER M8	1	UNI 6592 DIN 125-A	
43	ROLLER SHAFT	1	4100102	
44	NUT M8	1	UNI 5587	
45	STUD M6 x 6	1	DIN 5929	
46	STUD M6 x 6	1	DIN 5929	
47	NUT M6	1	UNI 5587	
48	STUD	1	4101449	
49	SCREW M6 x 25	1	UNI 5931 DIN 912	
50	SCREW M6 X 18	1	UNI 5931 DIN 912	
57	DU 27-24-20	2	3030828	
58	RUBBER	1	3030407	
59	SCREW TCEI M6X35	1	UNI 5931 DIN 912	
60	NUT M6	1	UNI 5587	
61	BUSHING ARM	1	4010042	
62	NUT M10 SHORT	1	UNI 5589	
63	PLASTIC STUD M10X	1	3031342	
64	PLASTIC STUD M10X	1	3031342	
65	PLASTIC TAP	1	4101006	
66	SHAFT INTERLOCK	1	AVAILABLE WITHIN THE GROUP 203V009	
66	SHAFT INTERLOCK	1	AVAILABLE WITHIN THE GROUP 203V009N	FROM S.N. 04198957
67	INTERLOCK SPRING	1	AVAILABLE WITHIN THE GROUP 203V009	
67	INTERLOCK SPRING	1	AVAILABLE WITHIN THE GROUP 203V009N	FROM S.N. 04198957
68	M8X25 STUD	1	UNI5929	
69	BUSHING INTERLOCK	1	AVAILABLE WITHIN THE GROUP 203V009	
69	BUSHING INTERLOCK	1	AVAILABLE WITHIN THE GROUP 203V009N	FROM S.N. 04198957
70	MUSHROOM LOCK ARM	1	4100171	
71	KNOB VB70 LOCKING ARM	1	AVAILABLE WITHIN THE GROUP 203V210	
71	KNOB VB70 LOCKING ARM	1	AVAILABLE WITHIN THE GROUP 203V210N	FROM S.N. 04198957
72	BUSHING LOCKING ARM	1	AVAILABLE WITHIN THE GROUP 203V210	
72	BUSHING LOCKING ARM	1	AVAILABLE WITHIN THE GROUP 203V210N	FROM S.N. 04198957
73	SHAFT LOCKING ARM	1	AVAILABLE WITHIN THE GROUP 203V210	
73	SHAFT LOCKING ARM	1	AVAILABLE WITHIN THE GROUP 203V210N	FROM S.N. 04198957
74	SCREW M8X25	1	UNI5933 DIN 7991	
75	BUSHING BEARING	1	4100115	
76	BEARING	1	3030302	
77	STUD M4X10	1	UNI5929	
78	ARM	1	4020792	
001	COMPLETELY BUSHING SUPPORT ARM	1	2030801	
002	COMPLETELY KNOB	1	2V30012	
003	COMPLETELY SUPPORT FENCE	1	2050005	

FIGURE 2

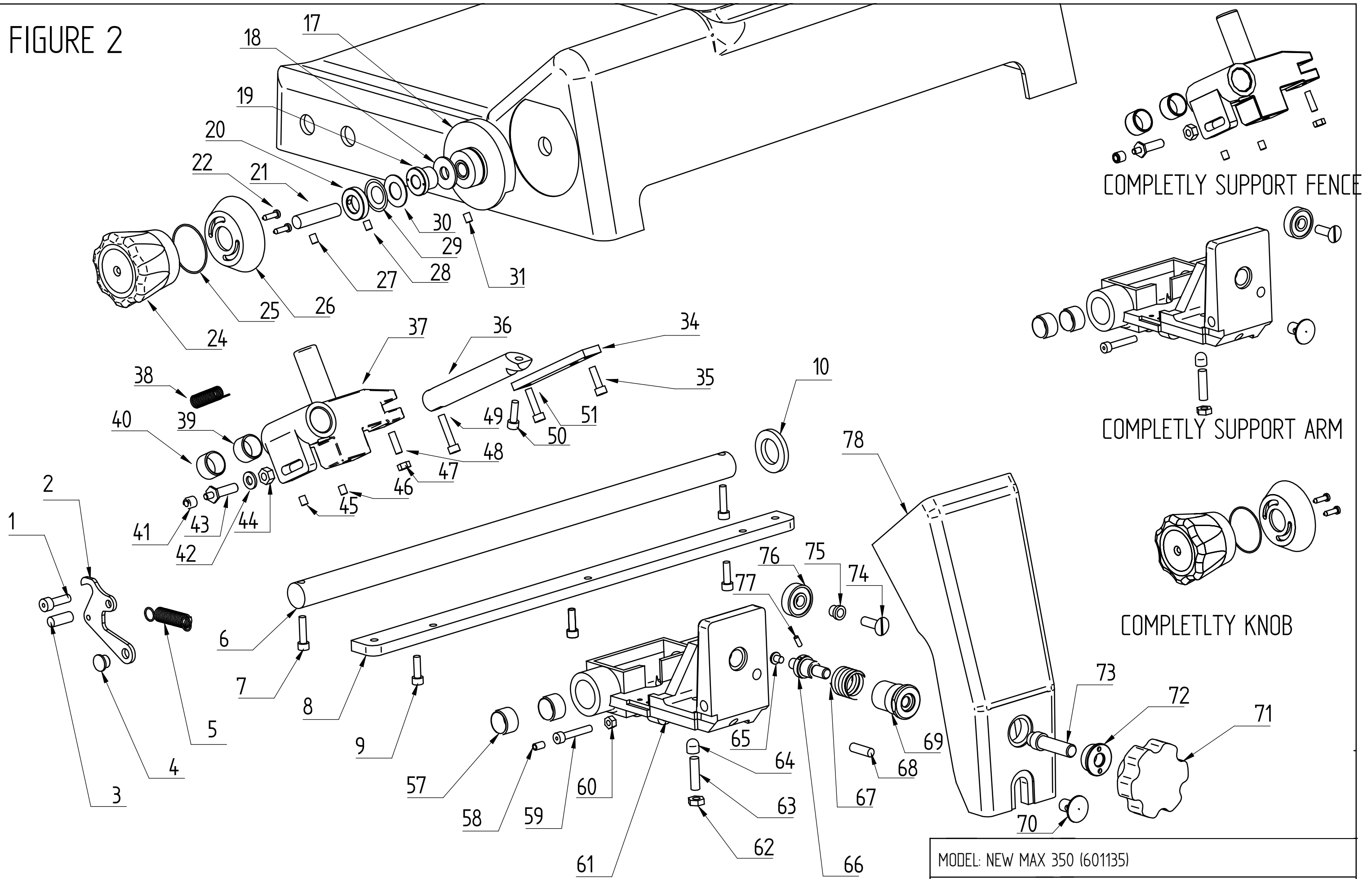

MODEL: NEW MAX 350 (601135)
FIGURE 2: INDEXING KNOB-SUPPORT FENCE-SUPPORT CARRIAGE ARM
EDITION: 1° DATE 02-2017

FIGURE 3: MOTOR - CABLE - SWITCH

No	DESCRIPTION	Q.	PART #	NOTE
1	STOP SWITCH INOX IP67	1	3040197	
2	START SWITCH INOX IP67	1	3040198	
3	ON-OFF LABEL	1	3039954	
4	STREIN RELIEF	1	3040626	
5	POWER SUPPLY CORD 115/60/1	1	3040504	
5	POWER SUPPLY CORD 400/50/3	1	3040606 + (3040666 PLUG)	
5	POWER SUPPLY CORD 220/50/1	1	3040518	
6	RUBBER WASHER	1	3030523	UNITL S.N. 03162252
7	SUPPORT RUBBER WASHER	1	403E018	UNITL S.N. 03162252
8	KEY 4X4X25	1	UNI6604-A	
9	SPACER 8 14 1	2	DIN988	UNITL S.N. 01160000
10	MOTOR 1/2HP 115/60/1	1	3010165	
10	MOTOR 1/2HP 400/50/3	1	3010200	
10	MOTOR 1/2HP 220/50-60/1	1	3010107	
11	NUT M8	4	UNI5587	
12	WASHER M8	4	UNI6592 DIN125-A	
13	SHAFT LOCKING MOTOR	4	4100581	
14	WARM 5P	1	4080101	
15	SPRING	1	3031270	
16	SPECIAL NUT LOCKING SPRING	1	4100889	
17	SCREW 3,9 X 9,5	2	UNI6954 DIN7981	
18	ELECTRICAL CARD 115/60/1	1	3040221	
18	ELECTRICAL CARD 400/50/3	1	3040657	
18	ELECTRICAL CARD 220/50-60/1	1	3040758	TYPE MAB-F-LC
18	ELECTRICAL CARD 220/50-60/1	1	3040802	TYPE EB-115/230 CS01052018LC
19	RUBBER WASHER	2	3030514	
20	PLASTIC BOX	1	4090103	
21	SCREW TCEI M5X60	2	UNI5931 DIN 912	
22	WASHER 6 - 18	1	UNI6593	
23	CAPACITOR 30MF 115/60/1	1	3040309	
23	CAPACITOR 10MF 220/50-60/1	1	3040301	
001	COMPLETLY MOTOR 115/60/1	1	2010406	ED.1 12-12
001	COMPLETLY MOTOR 400/50/3	1	2010405	ED.1 12-12
001	COMPLETLY MOTOR 220/50-60/1	1	2010401	ED.1 12-12
002	COMPLETLY ELCTRIC BOARD 400/50/3	1	3040764	
002	COMPLETLY ELCTRIC BOARD 220/50-60/1	1	3040763	
002	COMPLETLY ELCTRIC BOARD 115/60/1	1	3040221	

FIGURE 3

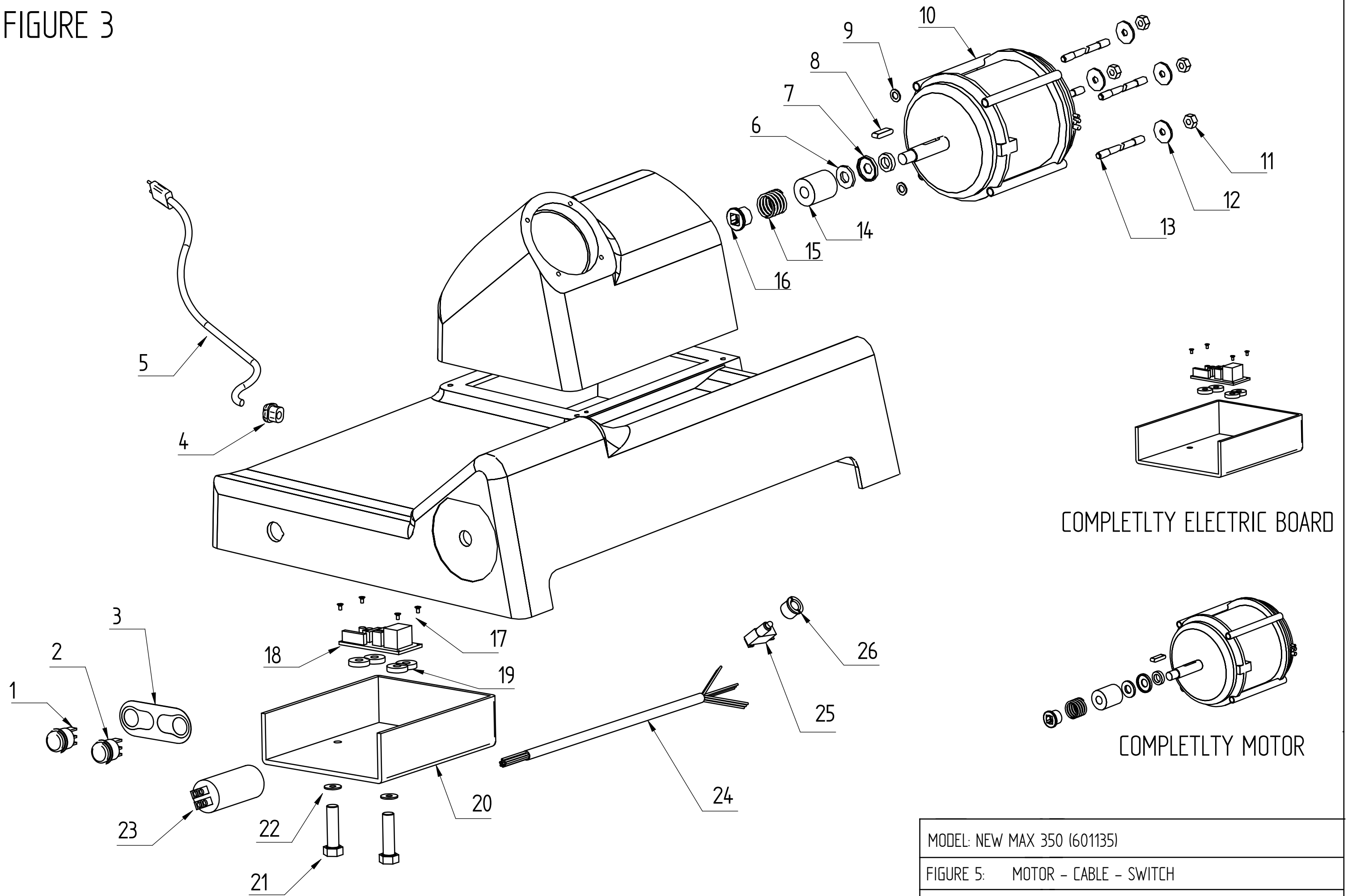

COMPLETELY ELECTRIC BOARD

COMPLETELY MOTOR

MODEL: NEW MAX 350 (601135)

FIGURE 5: MOTOR - CABLE - SWITCH

EDITION: 1° DATE 02-2017

FIGURE 4: CARRIEGE TRAY AND CARRIEGE TRAY SUPPORT

No	DESCRIPTION	Q.	PART #	NOTE
425	CARRIAGE	1	4020784	
426	SHAFT LIFT MEAT HOLDER	1	4100935	
427	MEAT HOLDER	1	4020293	
428	PINS	22	4100895	
429	SHAFT PROTECTION	1	4101063	
430	TAP	1	4100776	
431	SHAFT MEAT HOLDER KNOB	1	4101080	UNTIL S.N. 08160000
432	SPACER	1	4100827	
433	MEAT HOLDER KNOB	1	4090368	
434	BUSHING	2	3030814	
435	ROUND BAR	1	4100031	
436	ROUND BAR KNOB	1	4090302	
437	SCREEW PROTECION HOLDER	2	700254F	
438	NUT M6	2	7004006	
439	SPACER	2	4060987	
440	PROTECTION	1	4101055	
441	NUT M6	2	7004006	
443	METAL SHEET LIFT MEAT HOLDER	1	405FC34	
444	SCREEW	2	7001347	
445	TAP	1	700325B	UNTIL S.N. 01060000
446	WASHER	1	7001010	
447	STUD M8X40 H45	2	7000270	
448	SPECIAL WASHER	2	7000710	
449	NUT M8	2	7000487	
0144	GROUP MEAT HOLDER DA N° 427 A N° 434	1	2090301	

400

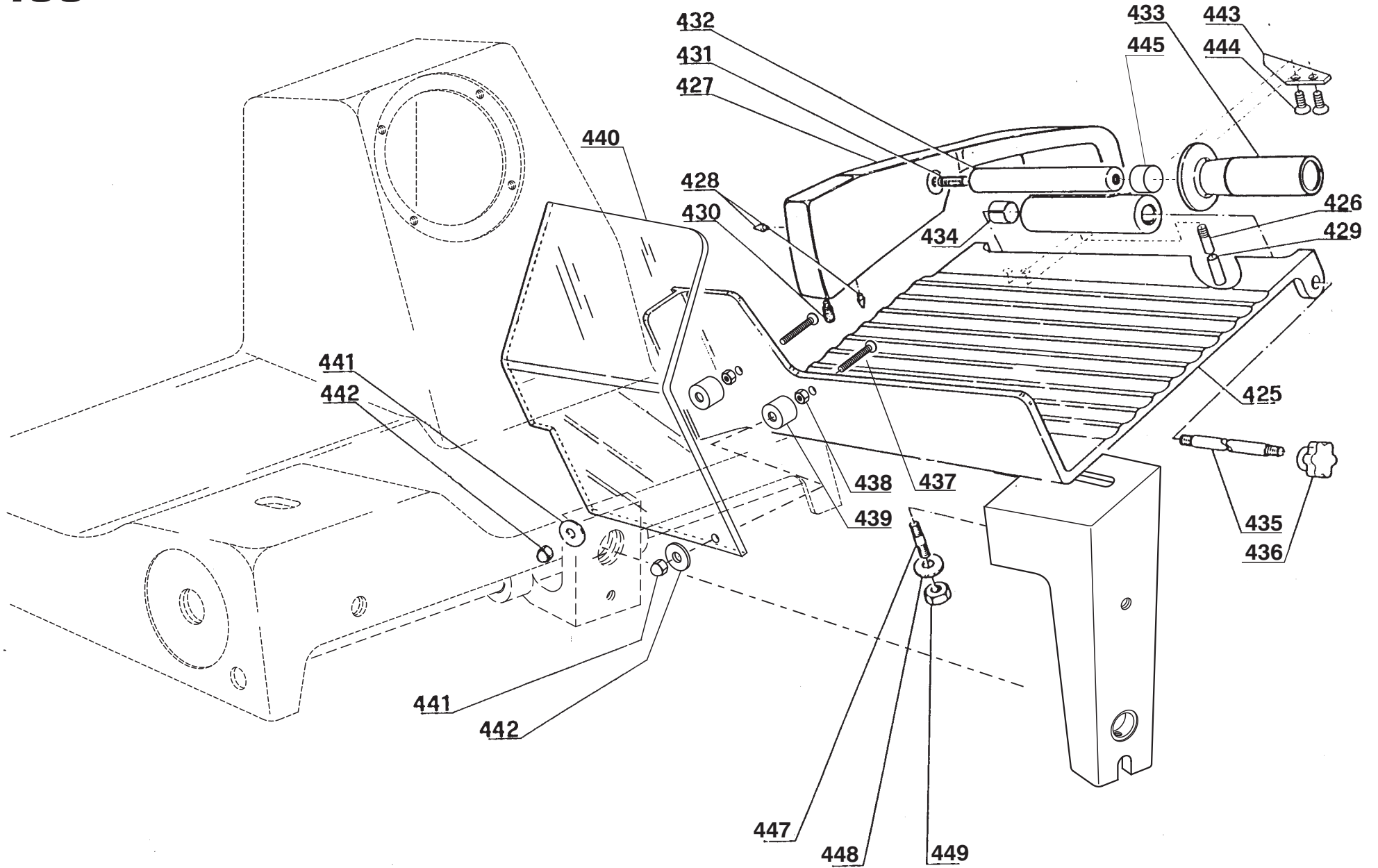
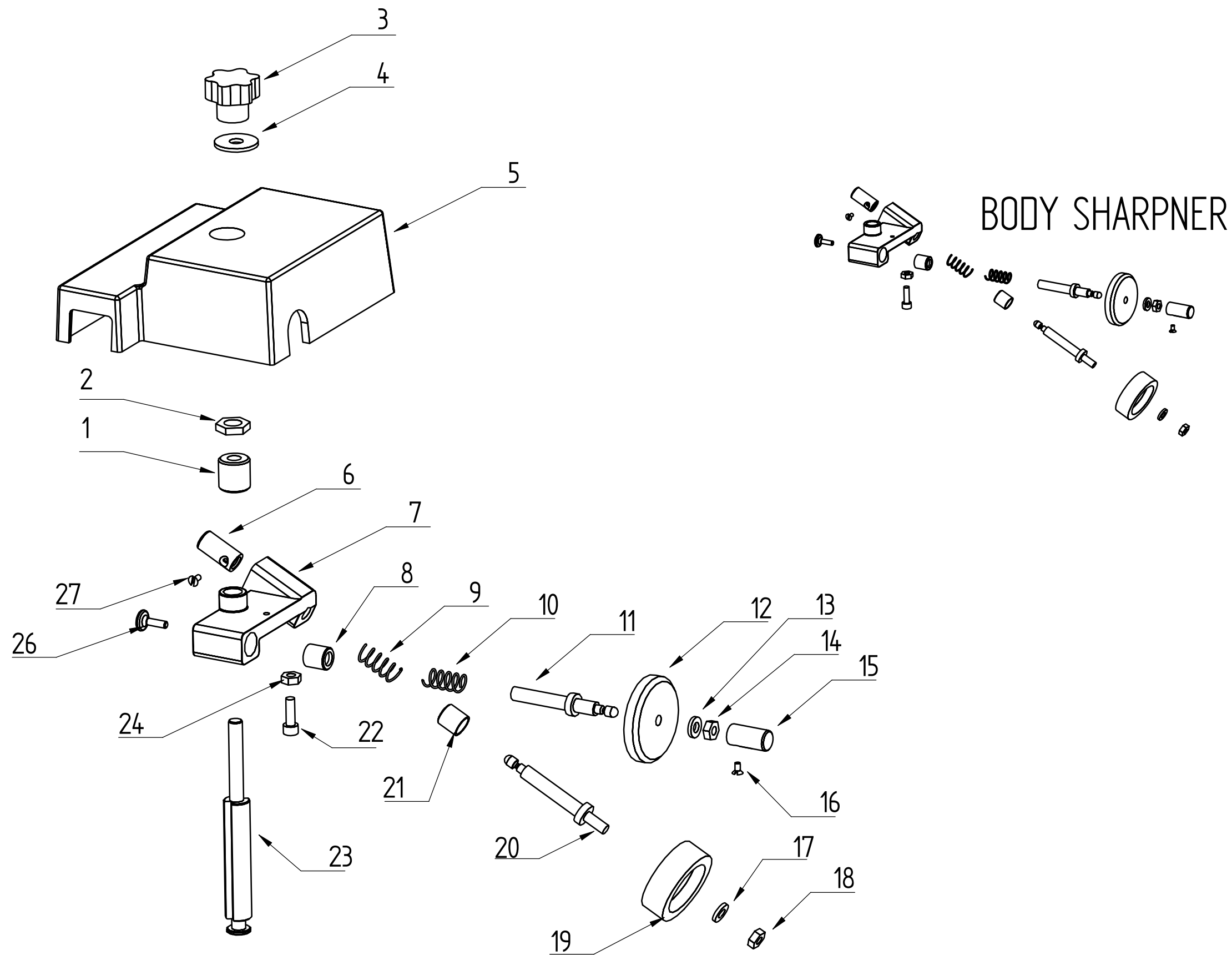

FIGURE 5: COMPLETELY SHARPNER

No	DESCRIPTION	Q.	PART #	NOTE
1	WASHER M8	1	STAINLESS STEEL UNI 6592 DIN 125-A	
2	NUT M8	1	STAINLESS STEEL UNI 5589 DIN 936	
3	KNOB M8	1	4090302	
4	WASHER M8	1	STAINLESS STEEL UNI 6593 DIN 9021	
5	SHARPENER COVER	1	4020132	
6	BUTTON ,STONE DEPRESS	1	4100625	
7	MOUNT	1	AVAILABLE IN THE PART# 001	
8	BUSHING	1	4100069	
9	SPRING	1	3031204	
10	SPRING	1	3031204	
11	STUD HONING	1	4100273	
12	STONE , HONING	1	3030704	
13	WASHER M8	1	STAINLESS STEEL UNI 6592 DIN 125-A	
14	NUT M8	1	STAINLESS STEEL UNI 5589 DIN 936	
15	BUTTON ,STONE DEPRESS	1	4100625	
16	SCREEW	1	4100594	
17	WASHER M6	1	STAINLESS STEEL UNI 6592 DIN 125-A	
18	NUT M6	1	STAINLESS STEEL UNI 5588 DIN 934	
19	STONE, SHARPENING	1	3030716	
20	STUD ,SHAROPENING	1	4100275	
21	BUSHING	1	4100069	
22	SCREEW	1	3031334	
23	PIN , SET	1	4101015	
24	NUT M5	1	STAINLESS STEEL UNI 6592 DIN 125-A	
25	NUT	1	4100103	
26	SCREEW	1	7900021	
27	SCREEW	1	4100594	
001	BODY SHARPNER	1	2070103R	
002	COMPLETELY SHARPENER (FROM 1 TO 27)	1	2070104R	

FIGURE 5



MODEL: NEW MAX 350_601135

FIGURE 5: SHARPNER

EDITION: 1° DATE 02-2017