

**DE** GAS FRITTEUSEN 14L / 23L  
**EN** GAS DEEP FAT FRYER 14L / 23L

PNC	Factory Model	Ref.	Description
588687	MBFHGBDDPO	a	14L FRYER, C-BOARD, 400X850X700H
589504	MCFHEADPO	b	14L FRYER, 400X900X700H
589505	MCFHEBDDPO	b	14L FRYER, C-BOARD, 400X900X700H
589506	MCFHFADDPO	c	14L FRYER, 400X900X800H
589507	MCFHFBDDPO	c	14L FRYER, C-BOARD, 400X900X800H
588632	MBFDGBEDPO	d	23L FRYER, C-BOARD, 500X850X700H
589302	MCFDEAEDPO	e	23L FRYER, 500X900X700H
589303	MCFDEBEDPO	e	23L FRYER, C-BOARD, 500X900X700H
589459	MCFDFAEDPO	f	23L FRYER, 500X900X800H
589460	MCFDFBEDPO	f	23L FRYER, C-BOARD, 500X900X800H

Page	Index	Last Updates	Page
2	Mechanical Module 14L	12/2015	all
4	Gas heating system 14L	05/2016	all
6	Mechanical Module 23L	12/2016	10 / 11
8	Gas heating system 23L	04/2017	10 / 11
10	Other parts 14L / 23L		

Valid from Ser. № 3101....

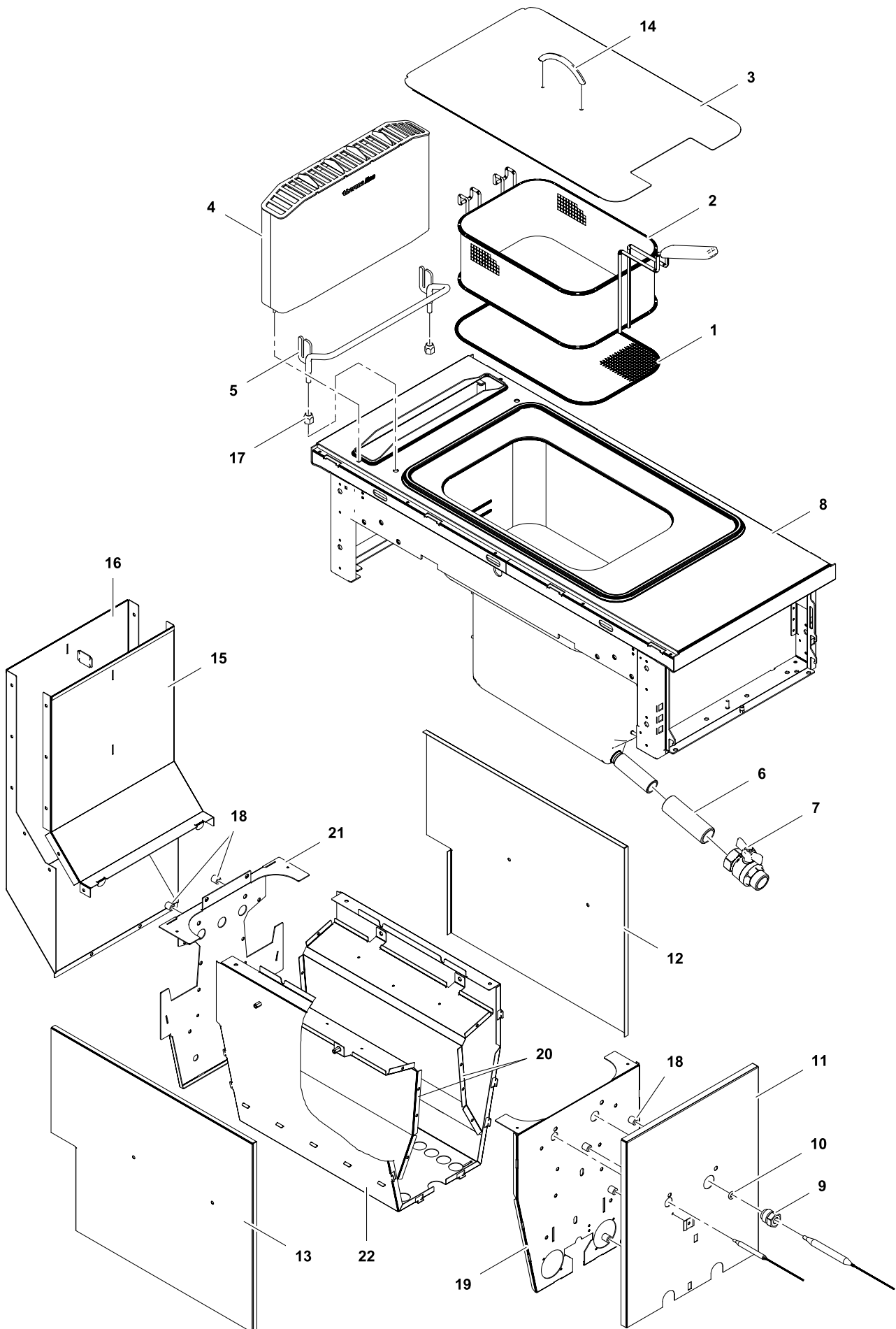

1	Alias	Code	Bezeichnung	Description	Ref.	Valid from Serial N°
1	1 701 2748	005932	Schmutz Fangsieb	Strainer	all types	
2	82.7369	005933	Frittierkorb 14L	Frying basket 14L	all types	
3	82.2119	0G6968	Deckel	Lid	all types	
4	82.4044.01		Kamin Typ 400	Chimney type 400	all types	
5	82.7136	OTTK58	Bügel	Hanger	all types	
6	82.7370.01	0G6984	Doppelnippel	Double nipple	all types	
7	82.7117	0G6724	Kugelhahn 1"	Ball valve 1"	all types	
8	82.0664.04	*	Top Fryer 14L Geschweisst T850 CB	Top Fryer 14L Welded D850 CB	a	
	82.0664.07	*	Top Fryer 14L Geschweisst T900	Top Fryer 14L Welded D900	b c	
	82.0664.08	*	Top Fryer 14L Geschweisst T900 CB	Top Fryer 14L Welded D900 CB	b c	
9	82.7312	0CA470	Verschraubung Ø5	Fitting Ø5	all types	
10	82.7122	059293	Dichtung Ø3,68xØ1,78	Sealing Ø3,68xØ1,78	all types	
11	82.2513		Frontblech	Frontpanel	all types	
12	82.2514.01		Seitenblech rechts	Sidepanel right	all types	
13	82.2514.02		Seitenblech links	Sidepanel left	all types	
14	82.7097	0C0614	Griff für Deckel	Handle for Lid	all types	
15	82.2507		Kamin vorne	Chimney front part	all types	
16	82.2508		Kamin hinten	Chimney back side	all types	
17	82.7116	0C6012	Buchse	Bushing	all types	
18	82.7110	052263	Distanzstück	Spacer	all types	
19	82.2510	*	Mantel vorne	Front cover	all types	
20	82.2512	*	Blech hinten	Cover Sheet back	all types	
21	82.2511	*	Mantel hinten	Back Cover	all types	
22	82.2509	*	Mantel	Coat	all types	

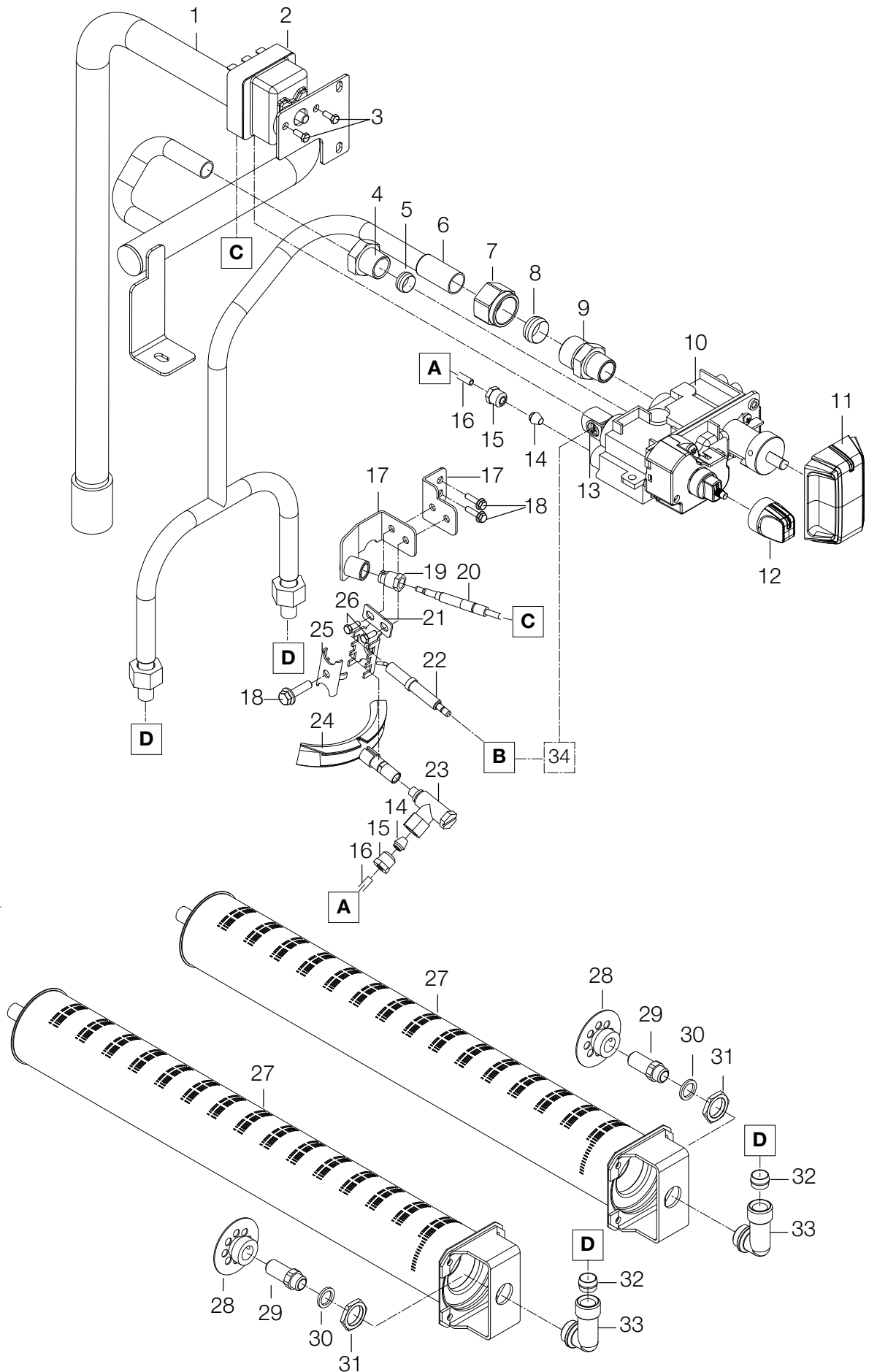

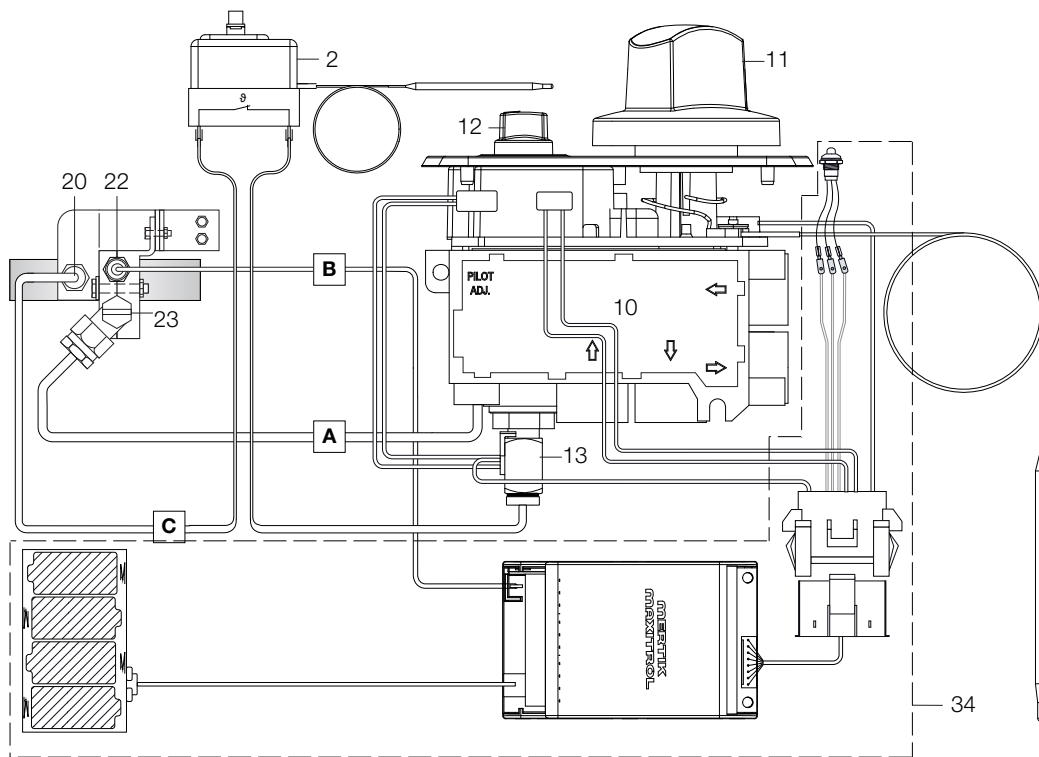

2	Alias	Code	Bezeichnung	Description	Ref.	Valid from Serial N°
1	82.7380	*	Gas Rampe	Gas line	all 14L	
2	1 115 1614	006282	Sicherheitstemperaturbegrenzer	Safety temperature limiter	all 14L	
3	1 701 7504		Blechschaube 4.2x9.5	Tapping screw 4.2x9.5	all 14L	
4	82.7045	051950	Verschraubung D12 3/8"	Fitting D12 3/8"	all 14L	
5	82.7044	050682	Klemmring D12	Clamp ring D12	all 14L	
6	82.7379	*	Gaszuleitung Brenner	Gas line burner	all 14L	
7	82.7128	0C9127	Mutter Ø15	Nut Ø15	all 14L	
8	82.7129	0C9126	Doppelkegelring Ø15	Double cone ring Ø15	all 14L	
9	82.7127	0C8474	Verschraubung Ø15	Fitting Ø15	all 14L	
10	82.2438	0G7801	Mertik Ventil	Mertik valve	all 14L	
11	82.7566	0G7833	Drehgriff	Handle	all 14L	
12	82.7003	0G6345	Drehgriff Mertik	Handle Mertik	all 14L	
13	82.9087	*	Thermischer Stromunterbrecher GV60 M9x1	Thermocurrent interrupter GV60 M9x1	all 14L	
14	1 701 2757	0G2960	Klemmring D4	Clamp ring D4	all 14L	
15	72.7742		Verbindungsanschluss	Connection port	all 14L	
16	82.7381	*	Gaszuleitung Zündleitung	Gas line ignition wire	all 14L	
17	82.2517	0C8935	Halter Zündbrenner	Holder Ignition burner	al 14L	
18	72.7919	0G2927	Schraube spezial	Special scre	all 14L	
19	1 106 1236	0C0121	Thermoelementschaube	Thermocouple screw	all 14L	
20	72.7793	0C3162	Thermoelement	Thermocouple	all 14L	
21	72.7917		Bügel	Binder	all 14L	
22	82.4220	0C7141	Zündkerze	Spark plug	all 14L	
23	72.7912	052686	Pilot-Körper D0.35	Pilot body D0.35	all 14L	
24	82.7383	0A5441	Zündbrennerblech	Sheet metal for Ignition torch	all 14L	
25	72.7918		Gegenstück	Counterpart	all 14L	
26	1 701 2507	0G4653	Schraube M5x10	Screw M5x10	all 14L	
27	82.7378	005929	Brenner	Burner	all 14L	
28	1 106 1202	054039	Halter Gasdüse	Holder Nozzle	all 14L	
29	See nozzle list	-	Düse	Nozzle	all 14L	
30	72.7747	054029	Dichtung zu Düse	Gasket to nozzle	all 14L	
31	72.7748	020997	Gegenmutter zu Düse	Counter nut to nozzle	all 14L	
32	1 701 2732		Doppelkegelring Ø10	Double cone ring Ø10	all 14L	
33	82.7126		Düsenträger	Holder for nozzle	all 14L	
34	82.7561	0G7885	Gas Kit Mertik	Gas Kit Mertik	all 14L	

\* Components on demand  
\* Teile auf Anfrage

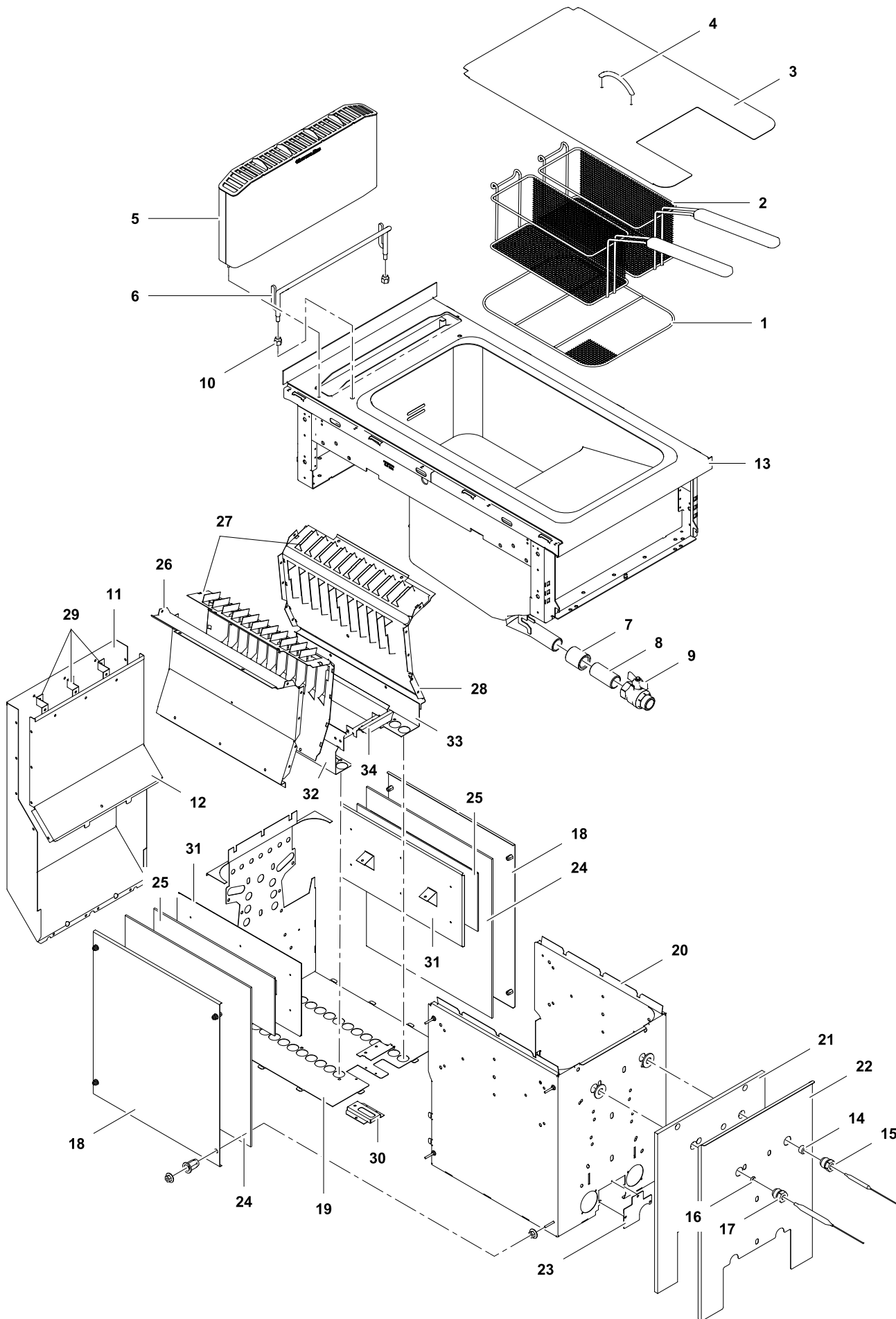

<b>3</b>	Alias	Code	Bezeichnung	Description	Ref.	Valid from Serial N°
1	1 701 2749	006130	Schmutz Fangsieb	Dirty Strainer	all types	
2	6 001 3280	006133	Frittierkorb	Frying Basket	all types	
3	82.2099	0G7063	Deckel	Lid	all types	
4	82.7097	0C0614	Griff für Deckel	Handle for lid	all types	
5	82.4044.02		Kamin Typ 500	Chimney type 500	all types	
6	82.7106	006583	Buegel	Hanger	all types	
7	82.7113	0G7065	Gewindemuffe 1"x43mm	Threaded socket 1"x43mm	all types	
8	82.7114		Doppelnippel 1" L=70mm	Double nipple 1" L=70mm	d	
	82.7339.01	0G7066	Doppelnippel 1" L=100mm	Double nipple 1" L=100mm	e f	
9	82.7117	0G6724	Kugelhahn 1"	Ball Valve 1"	all types	
10	82.7116	0C6012	Buchse	Bushing	all types	
11	82.2101		Kamin hinten	Chimney back side	all types	
12	82.2100		Kamin vorne	Chimney front side	all types	
13	82.0554.04	*	Top Fryer Geschweisst T850 CB	Top Fryer welded D850 CB	d	
	82.0554.07	*	Top Fryer Geschweisst T900	Top Fryer welded D900	e f	
	82.0554.08	*	Top Fryer Geschweisst T900 CB	Top Fryer welded D900 CB	e f	
14	82.7120	002075	Dichtung Ø6	Sealing Ø6	all types	
15	82.7119	002076	Verschraubung Ø6	Fitting Ø6	all types	
16	82.7122	059293	Dichtung Ø3,68xØ1,78	Sealing Ø3,68xØ1,78	all types	
17	82.7312	0CA470	Verschraubung Ø5	Fitting Ø5	all types	
18	82.4226	*	Blech Seite	Side Panel	all types	
19	82.2103	*	Mantel hinten	Back casing	all types	
20	82.2102	*	Mantel vorne	Front casing	all types	
21	82.7236		Isolierung vorne	Insulation front	all types	
22	82.2191	*	Blech vorne	Front panel	all types	
23	82.2111	*	Abdeckung Zündbrenner	Cover Ignition torch	all types	
24	82.7235		Isolation Seite	Insulation side	all types	
25	82.7125	0C3476	Isolierung Seite	Side Insulation	all types	
26	82.2104.02	*	Blech links	Plate Left	all types	
27	82.2106	*	Umlenblech	Baffle	all types	
28	82.2104.01	*	Blech rechts	Plate Right	all types	
29	82.2114	*	Distanzblech	Distance Plate	all types	
30	82.2108		Halter Zündbrenner	Support ignition torch	all types	
31	82.2107	*	Abdeckblech	Covering sheet	all types	
32	82.2113	*	Blech links	Plate left	all types	
33	82.2112	*	Blech rechts	Plate right	all types	
34	82.2109		Distanzblech	Spacer plate	all types	

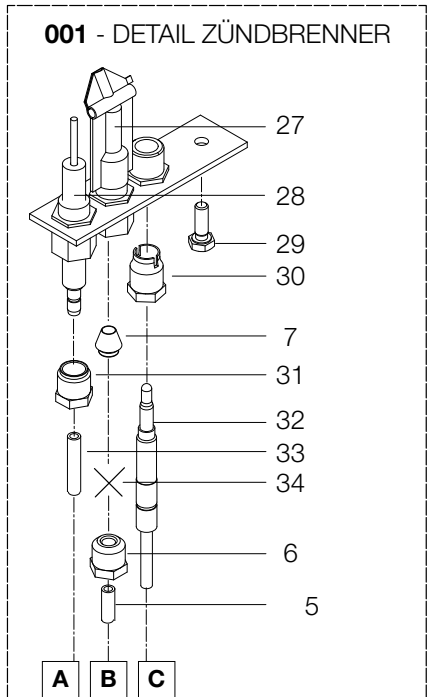
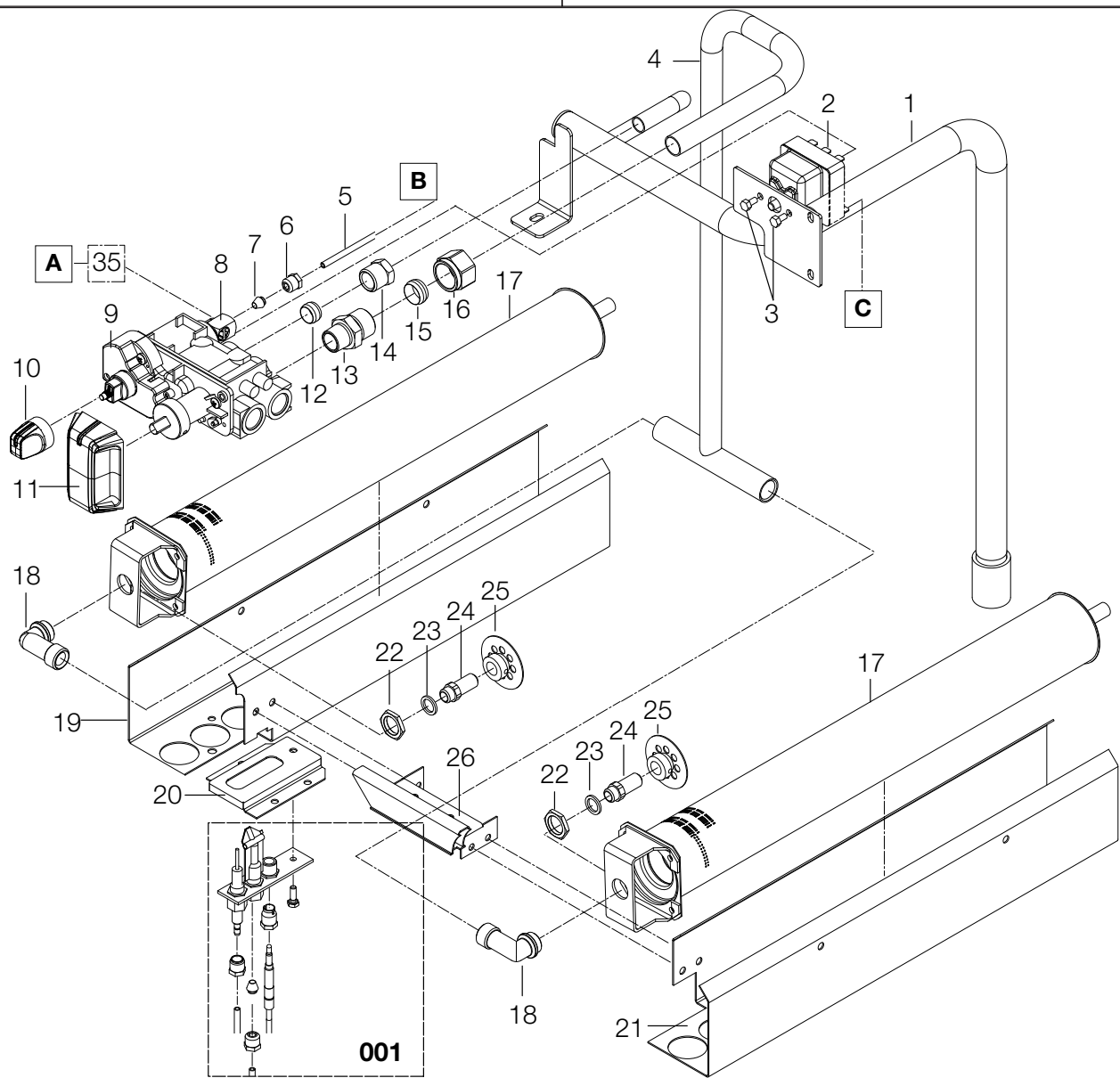



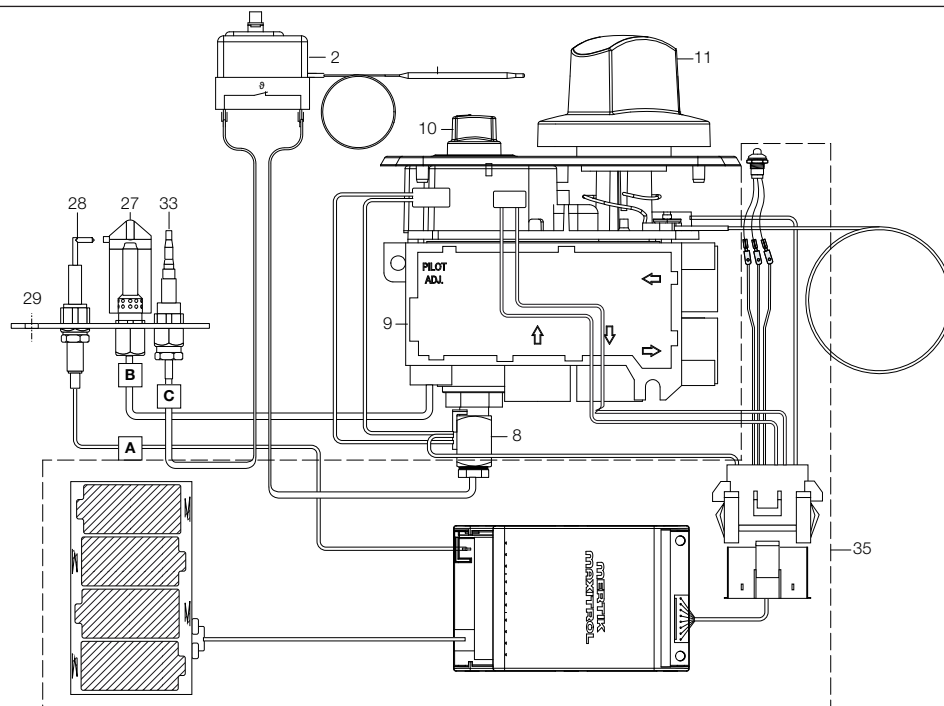

4	Alias	Code	Bezeichnung	Description	Ref.	Valid from Serial N°
1	82.7108	*	Gasrampe	Gas line	all 23L	
2	1 115 1614	006282	Sicherheitstemperaturbegrenzer	Safety temperature limiter	all 23L	
3	1 701 7504		Blechschaube 4.2x9.5	Tapping screw 4.2x9.5	all 23L	
4	82.7107	0G7884	Gasleitung Brenner	Gas line burner	all 23L	
5	82.7109	*	Gasleitung Zündleitung	Gas line ignition wire	all 23L	
6	72.7742		Verbindungsanschluss	Connection port	all 23L	
7	1 701 2757	0G2960	Klemmring D4	Clamp ring D4	all 23L	
8	82.9087	*	Thermischer Stromunterbrecher GV60 M9x1	Thermocurrent interrupter GV60 M9x1	all 23L	
9	82.2438	0G7801	Metik Ventil	Mertik valve	all 23L	
10	82.7003	0G6345	Drehgriff Mertik	Handle Mertik	all 23L	
11	82.7566	0G7833	Drehgriff	Handle	all 23L	
12	82.7044	050682	Klemmring D12	Clamp ring D12	all 23L	
13	82.7127	0C8474	Verschraubung Ø15	Fitting Ø15	all 23L	
14	82.7045	051950	Verschraubung D12 3/8"	Fitting D12 3/8"	all 23L	
15	82.7129	0C9126	Doppelkegelring Ø15	Double cone ring Ø15	all 23L	
16	82.7128	0C9127	Mutter Ø15	Nut Ø15	all 23L	
17	1 106 1201	006127	Brenner	Burner	all 23L	
18	82.7126		Düsenräger	Holder for nozzle	all 23L	
19	82.2113		Brennerblech links	Sheet metal for burner left	all 23L	
20	82.2108		Halter Zündbrenner	Holder Ignition burner	all 23L	
21	82.2112		Brennerblech rechts	Sheet metal for burner right	all 23L	
22	72.7748	020997	Gegenmutter zu Düse	Counter nut to nozzle	all 23L	
23	72.7747	054029	Dichtung zu Düse	Gasket to nozzle	all 23L	
24	See nozzle list	-	Düse	Nozzle	all 23L	
25	1 106 1202	054039	Halter Gasdüse	Holder Nozzle	all 23L	
26	82.2109		Durchgangsblech	Passage sheet metal	all 23L	
27	1 106 1204	0G2975	Zündbrenner	Ignition torch	all 23L	
28	72.7920	0K4320	Zündkerze	Spark plug	all 23L	
29	1 701 2629	0G5854	Schraube M4x12	Screw M4x12	all 23L	
30	1 106 1236	0C0121	Thermoelementschaube	Thermocouple screw	all 23L	
31	72.7759	057960	Anschlussselektrode	Connecting electrode	all 23L	
32	72.7793	0C3162	Thermoelement	Thermocouple	all 23L	
33	82.7428		Gasleitung Zündbrenner	Gas line ignitin burner	all 23L	
34	See nozzle list	-	Düse Zündbrenner	Nozzle ignition burner	all 23L	
35	82.7561	0G7885	Gas Kit Mertik	Gas Kit Mertik	all 23L	

\* Components on demand  
\* Teile auf Anfrage

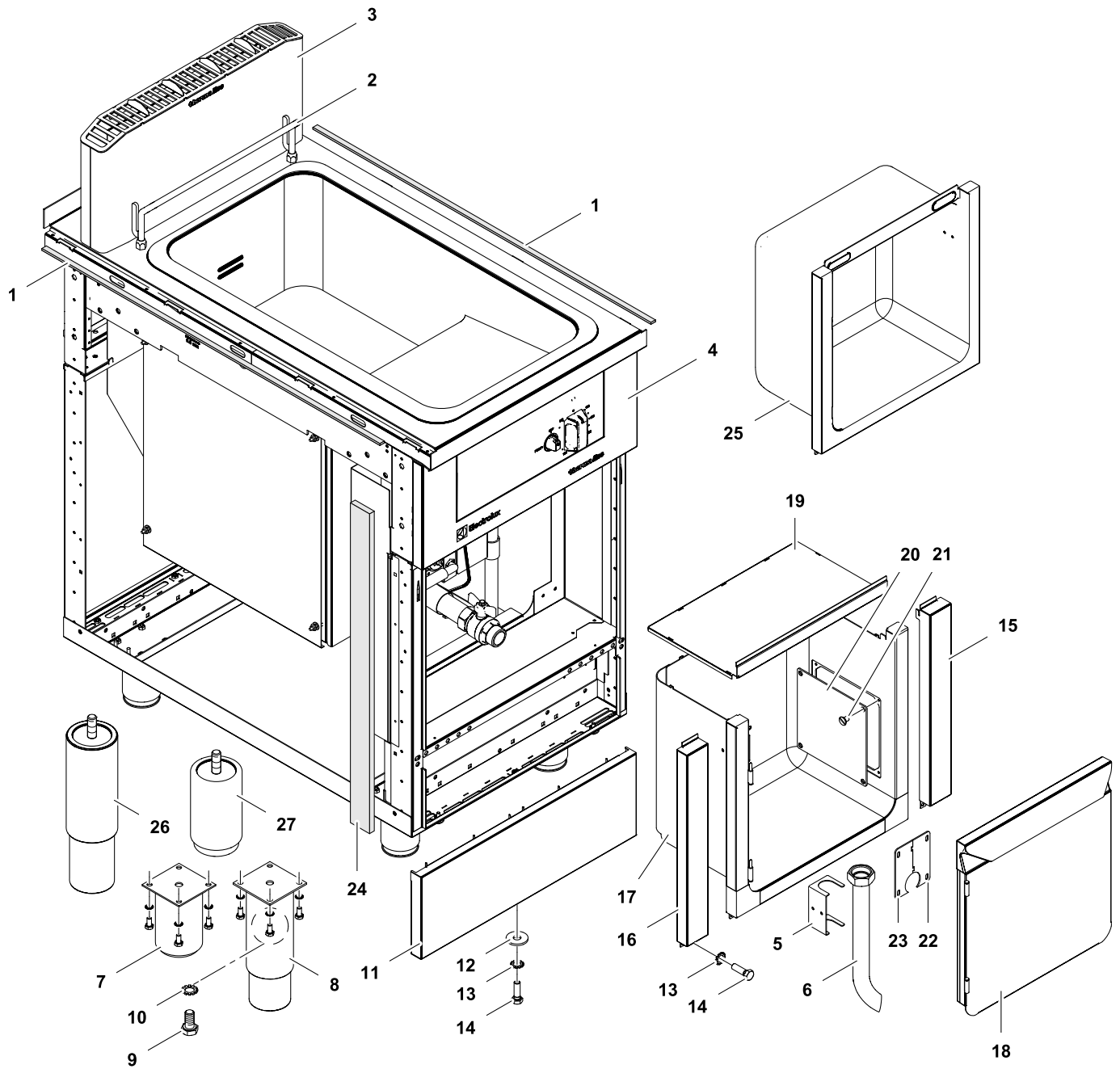

5	Alias	Code	Bezeichnung	Description	Ref.	Valid from Serial N°
1	82.7464	0C2496	Dichtband klebend	Adhesive sealing tape	all types	
2	82.7136	006583	Bügel 14L	Hanger 14L	a b c	
	82.7106	006583	Bügel 23L	Hanger 23L	d e f	
3	82.4044.01		Kamin Typ 400	Chimney type 400	a b c	
	82.4044.02		Kamin Typ 500	Chimney type 500	d e f	
4	82.1027.14	*	Bedienblende 400mm	Control Panel 400mm	b c	
	82.1027.13	*	Bedienblende 500mm	Control Panel 500mm	e f	
	82.1049.10	*	Bedienblende 500mm	Control Panel 500mm	d	
	82.1049.88	*	Bedienblende 400mm	Control Panel 400mm	a	
5	82.2379	0G7079	Haltewinkel	Bracket	all types	
6	82.7118	0C7974	Ölablass	Oil drain	all types	
7	86.2385	0G6140	Fuss 2" 100mm	Foot 2" 100mm	c f	
8	86.0001	0G5391	Fuss 2" 200mm	Foot 2" 200mm	a b d e	
9	1 701 2600	OKT919	Schraube 6kt M6x12	Hex screw M6x12	all types	
10	1 701 5051	0G6753	Fächerscheibe M6	Fan washer M6	all types	
11	82.1140.04	0G7122	Anschlussdeckel H66 / L400	Lower panel H66 / L400	a b	
	82.1140.24	0G7469	Anschlussdeckel H166 / L400	Lower panel H166 / L400	c	
	82.1140.05	0G7287	Anschlussdeckel H66 / L500	Lower panel H66 / L500	d e	
	82.1140.25	0G7900	Anschlussdeckel H166 / L500	Lower panel H166 / L500	f	
12	1 701 3535	0G3588	U-Scheibe Ø5.3xØ10x1	Washer Ø5.3xØ10x1	all types	
13	1 701 7002	0G2923	Fächerscheibe M5	Fan washer M5	all types	
14	1 701 2579	0G4020	Schraube 6kt M5x16	Hex screw M5x16	all types	
15	82.1041.06		Korpusabdeckung rechts	Body Cover right	e f	
16	82.1042.06		Korpusabdeckung links	Body Cover left	e f	
17	82.2428	*	Korpus NHC Fritteuse 23L	Corpus NHC Fryer 23L	d	
	82.0240	*	Korpus Fritteuse 23L	Corpus Fryer 23L	e f	
	82.0243	*	Korpus Fritteuse 14L	Corpus Fryer 14L	b c	
	82.2504.02	*	Korpus NHC Fritteuse 14L	Corpus NHC Fryer 14L	a	
18	82.0250.01	0G7350	Türe	Door	b c e f	
	82.1071.01	0G7347	Türe NHC	Door NHC	a d	
19	82.0249.01		Deckel zu Korpus 14L	Lid to corpus 14L	b c	
	82.2518		Deckel zu NHC Korpus 14L	Lid to NHC corpus 14L	a	
	82.0240		Deckel zu Korpus 23L	Lid to corpus 23L	e f	
	82.0248.01		Deckel zu Korpus 23L	Lid to corpus 23L	d e f	
	82.0248.02		Deckel zu Korpus 23L	Lid to corpus 23L	Marine	
20	82.0124	0G7785	Deckel Servicefenster	Cover service opening	e f	
	82.0223.01	0G6757	Deckel Servicefenster	Cover service opening	d	
21	1 701 1145	0G6758	Senkschraube M4x6	Countersunk screw	d e f	
22	82.2253	*	Rosette Ablaufhahn rechts	Cover drain right	a d	
	82.2601	*	Rosette Ablaufhahn rechts 23L T900	Cover drain right 23L D900	e f	
	82.2827	*	Rosette Ablaufhahn rechts 14L	Cover drain right 14L	b c	
	82.1205	*	Rosette Ablaufhahn rechts	Cover drain right	a d	6481...
	82.1203	*	Rosette Ablaufhahn rechts T900	Cover drain right D900	b c e f	6481...
23	82.2254	*	Rosette Ablaufhahn links	Cover drain left	a d	
	82.2602	*	Rosette Ablaufhahn links 23L T900	Cover drain left 23L D900	e f	
	82.2826	*	Rosette Ablaufhahn links 14L	Cover drain left 14L	b c	
	82.1206	*	Rosette Ablaufhahn links	Cover drain left	a d	6481...
	82.1204	*	Rosette Ablaufhahn links T900	Cover drain left D900	b c e f	6481...
24	82.7467	0C7307	Seitliche Dichtung	Sealing sideways	all types	
25	82.0287.02	*	Korpus Fritteuse 23L	Corpus Fryer 23L	e f	6491...
	82.0287.01	*	Korpus Fritteuse 14L	Corpus Fryer 14L	b c	6491...
26	82.0350.01		Fuss M10 200mm	Foot M10 200mm	a b d e	7141...
27	82.0350.02		Fuss M10 100mm	Foot M10 100mm	c f	7141...



# Electrolux

## thermaline 80 / 85 / 90 Nozzle list / Düsentabelle

Appliance:

**DEEP FAT FRYER 14 L**

**14 kW**

**MxFHxxxxPx**

Range: **850 / 900**

Doc N° **82.8011.04**

Town Gas	GAS TYPE	COUNTRY	NOMINAL PRESS.	GAS TYPE <small>Lesigés</small>	CATAGORY	Pressure Regulator $\pm 1\%$	Nozzle C main burner (Abb. 2)			Small adjusting nozzle			Nozzle F ignition burner (Abb. 3)		Aeration adj. PILOT BURNER X (mm)	Aeration adj. MAIN BURNER D (mm) (Abb. 1)	Gas Consum.	Gas consumption L/min 956.5 mbar Baro / 20 °C Sursee Allmendstrasse		
							Type	mm	Alias N°	Spare Part N°	mm	Alias N°	Spare Part N°	N°				Alias N°	Ersatzteil N°	Min.
1	G 110	DK, SE	8	G110	1a	-	-	-	-	-	-	-	-	-	-	-	-	-	-	
2	G 120	SE		G120	1b	-	-	-	-	-	-	-	-	-	-	-	-	-	-	
3																				
4	Natural Gas H	HU	25	G25.1	2H	-	1.90	72.7803.11	054033	-	-	-	40	712 345056.05	OG6594	34.0	1,481 m³/h	23.87	25.12	26.38
							2.10	72.7803.42	056147	-	-	-	40	712 345056.05	OG6594	35.0	1,720 m³/h	27.62	29.07	30.53
5	Natural Gas L	AT, CH, DK, EE, ES, FI, GB, GR, IE, IT, LV, NO, PT, SE, SI, SK, BG, CZ, HR, LT, RO, TR, CZ	20	G20	2H	-	2.00	72.7803.12	OG2807	-	-	-	40	712 345056.05	OG6594	34.0	1,481 m³/h	23.87	25.12	26.38
							2.20	72.7803.12	OG2807	-	-	-	40	712 345056.05	OG6594	34.0	1,481 m³/h	23.87	25.12	26.38
6	Natural Gas E	DE, LU, PL	20	G20	2E	-	2.00	72.7803.12	OG2807	-	-	-	40	712 345056.05	OG6594	34.0	1,481 m³/h	23.87	25.12	26.38
7	Natural Gas H/L Pressure Couple	BE, FR	20/25	G20	2E+	-	2.00	72.7803.12	OG2807	-	-	-	40	712 345056.05	OG6594	34.0	1,481 m³/h	23.87	25.12	26.38
8							2.10	72.7803.42	056147	-	-	-	40	712 345056.05	OG6594	35.0	1,723 m³/h	27.62	29.07	30.53
9	Natural Gas L	NL	25	G25	2L	-	2.10	72.7803.42	056147	-	-	-	40	712 345056.05	OG6594	35.0	1,723 m³/h	27.76	29.22	30.68
10	Natural Gas LL	DE	20	G25	2LL	-	2.20	72.7803.43	055018	-	-	-	40	712 345056.05	OG6594	35.0	1,723 m³/h	27.76	29.22	30.68
11	Propan	CH, DE, FR, HU, NL	50	G31	3P	-	1.20	72.7803.41	OC2810	-	-	-	30	712 345056.03	OG6593	35.0	1,106 Kg/h	8.96	9.43	9.90
12							1.20	72.7803.41	OC2810	-	-	-	30	712 345056.03	OG6593	35.0	1,092 Kg/h	6.88	7.24	7.60
13	Butan/Propan	CZ, CY, DK, EE, FI, HU, LV, LT, MT, NL, NO, SE, SI, SK, BG, HR, IS, RO, TR	30	G30/31	3B/P	-	1.30	72.7803.03	059364	-	-	-	30	712 345056.03	OG6593	35.0	1,092 Kg/h	6.93	7.30	7.66
14							1.15	72.7803.06	005935	-	-	-	30	712 345056.03	OG6593	35.0	1,092 Kg/h	6.79	7.15	7.51
15	Butangas Propan Pressure Couple	BE, CH, ES, FR, GB, GR, IE, IT, PT, LT, SI, CZ, EE, LV, SK	28-30 / 37	G30/31	3+	-	1.30	72.7803.03	059364	-	-	-	30	712 345056.03	OG6593	35.0	1,092 Kg/h	6.93	7.30	7.66

Abb. 1



Abb. 2



Abb. 3



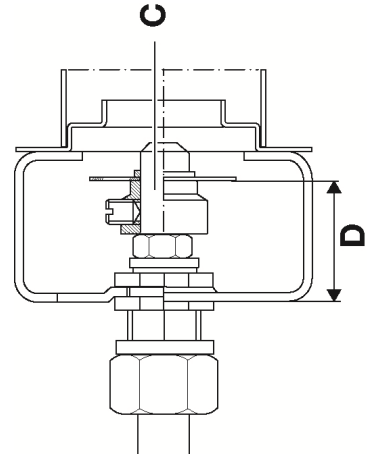

# Electrolux

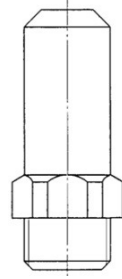
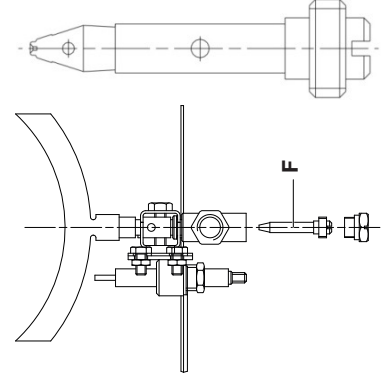
## therma<sup>line</sup> 80 / 85 / 90 Nozzle list / Düsentabelle

Appliance:

**DEEP FAT FRYER 23 L**

**21 kW**

Factory Model

**MxFDxxxxPx**

Range:

**850 / 900**

Doc N°

**82.8011.04**

Town Gas	GAS TYPE	COUNTRY	NOMINAL PRESS.	GAS TYPE <i>Testigas</i>	CATEGORY	Pressure Regulator ±1%	Nozzle C main burner (Abb. 2)			Small adjusting nozzle			Nozzle F ignition burner (Abb. 3)		Aeration adj. PILOT BURNER X (mm)	Aeration adj. MAIN BURNER D (mm) (Abb. 1)	Gas Consum.	Gas consumption L/min 956.5 mbar Baro / 20°C Sursee Alimentestrasse	
							Type	mm	Alias N°	Spare Part N°	mm	Alias N°	Spare Part N°	N°				Alias N°	Min.
1	G 110	DK, SE	8	G110	1a	-	-	-	-	-	-	-	-	-	-	-	-	-	-
2	G 120	SE	8	G120	1b	-	-	-	-	-	-	-	-	-	-	-	-	-	-
3			25	G20	2H	-	72.7803.14	0C0729	-	-	-	-	-	-	-	26	2.22 m <sup>3</sup> /h	35.80	37.68
4		HU	25	G25.1	2S	-	72.7803.40	0C4150	-	-	-	-	-	-	-	26	2.58 m <sup>3</sup> /h	41.43	43.61
5	Natural Gas H	AT, CH, DK, EE, ES, FI, GB, GR, IE, IT, LV, NO, PT, SE, SI, SK, BG, CZ, HR, LT, RO, TR, CZ	20	G20	2H	-	72.7803.39	003997	-	-	-	-	-	-	-	24	2.22 m <sup>3</sup> /h	35.80	37.68
6	Natural Gas E	DE, LU, PL	20	G20	2E	-	72.7803.39	003997	-	-	-	-	-	-	-	24	2.22 m <sup>3</sup> /h	35.80	37.68
7	Natural Gas H/L		20/25	G20	2E+	-	72.7803.39	003997	-	-	-	-	-	-	-	24	2.22 m <sup>3</sup> /h	35.80	37.68
8	Pressure Couple	BE, FR	25	G25	2L	-	72.7803.16	0C0747	-	-	-	-	-	-	-	26	2.58 m <sup>3</sup> /h	41.43	43.61
9	Natural Gas L	NL	20	G25	2LL	-	72.7803.32	006419	-	-	-	-	-	-	-	26	2.58 m <sup>3</sup> /h	41.64	43.83
10	Natural Gas LL	DE	20	G31	3P	-	72.7803.09	003722	-	-	-	-	-	-	-	32	1.66 Kg/h	13.44	14.15
11	Propan	CH, DE, FR, HU, NL	50	G31	3P	-	72.7803.09	003722	-	-	-	-	-	-	-	32	1.64 Kg/h	10.32	10.86
12		PL	37			-	72.7803.09	003722	-	-	-	-	-	-	-	32	1.64 Kg/h	10.32	10.86
13	Butan/Propan	CZ, CY, DK, EE, FI, HU, LV, LT, MT, NL, NO, SE, SI, SK, BG, HR, IS, RO, TR	30	G30/31	3B/P	-	72.7803.10	054127	-	-	-	-	-	-	-	32	1.64 Kg/h	10.40	10.94
14		AT, CH, DE	50			-	72.7803.02	056470	-	-	-	-	-	-	-	32	1.64 Kg/h	10.19	10.72
15	Butangas Propan Pressure Couple	BE, CH, ES, FR, GB, GR, IE, IT, PT, LT, SI, CZ, EE, LV, SK	28-30 / 37	G30/31	3+	-	72.7803.10	054127	-	-	-	-	-	-	-	32	1.64 Kg/h	10.40	10.94

Abb. 1



Abb. 2



Abb. 3

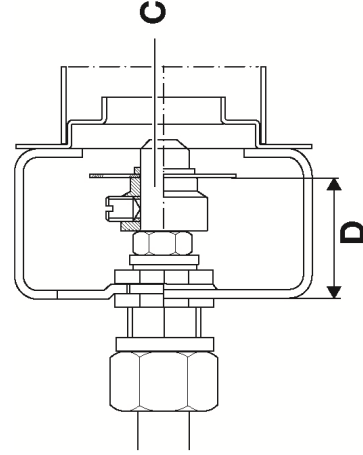
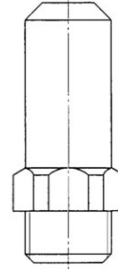