

DE GAS BRATPLATTEN 1 ZONE & 2 ZONEN
EN GAS FRY TOPS 1 ZONE & 2 ZONES
Appliances half module:

PNC	Factory Model	Ref.	Description
588532	MBHMBBDOPO	a	1 ZONE, TOP, SMOOTH PLATE, C-BOARD, 400X850X250
588536	MBHNBBDOPO	a	1 ZONE, TOP, RIBBED PLATE, C-BOARD, 400X850X250
593107	MBHMBBDOVO	a	1 ZONE, TOP, SMOOTH PLATE, C-BOARD, TOWNGAS, 400X850X250
593109	MBHNBBDOVO	a	1 ZONE, TOP, RIBBED PLATE, C-BOARD, TOWNGAS, 400X850X250
589092	MCHMAADOPO	b	1 ZONE, TOP, SMOOTH PLATE, 400X900X250
589093	MCHMABDOPO	b	1 ZONE, TOP, SMOOTH PLATE, C-BOARD, 400X900X250
589100	MCHNAADOPO	b	1 ZONE, TOP, RIBBED PLATE, 400X900X250
589101	MCHNABDOPO	b	1 ZONE, TOP, RIBBED PLATE, C-BOARD, 400X900X250
593318	MCHMAADOVO	b	1 ZONE, TOP, SMOOTH PLATE, TOWNGAS, 400X900X250
593319	MCHMABDOVO	b	1 ZONE, TOP, SMOOTH PLATE, C-BOARD, TOWNGAS, 400X900X250
593322	MCHNAADOVO	b	1 ZONE, TOP, RIBBED PLATE, TOWNGAS, 400X900X250
593323	MCHNABDOVO	b	1 ZONE, TOP, RIBBED PLATE, C-BOARD, TOWNGAS, 400X900X250
588667	MBHAGBDDPO	c	1 ZONE, UNIT, SMOOTH PLATE, C-BOARD, 400X850X700
588671	MBHCGBDDPO	c	1 ZONE, UNIT, RIBBED PLATE, C-BOARD, 400X850X700
593112	MBHAGBDDVO	c	1 ZONE, UNIT, SMOOTH PLATE, C-BOARD, TOWNGAS, 400X850X700
593114	MBHCGBDDVO	c	1 ZONE, UNIT, RIBBED PLATE, C-BOARD, TOWNGAS, 400X850X700
589536	MCHAEADDPO	d	1 ZONE, UNIT, SMOOTH PLATE, 400X900X700
589537	MCHAEADDPO	d	1 ZONE, UNIT, SMOOTH PLATE, C-BOARD, 400X900X700
589544	MCHCEADDPO	d	1 ZONE, UNIT, RIBBED PLATE, 400X900X700
589545	MCHCEADDPO	d	1 ZONE, UNIT, RIBBED PLATE, C-BOARD, 400X900X700
593328	MCHAEADDVO	d	1 ZONE, UNIT, SMOOTH PLATE, TOWNGAS, 400X900X700
593329	MCHAEADDVO	d	1 ZONE, UNIT, SMOOTH PLATE, C-BOARD, TOWNGAS, 400X900X700
593332	MCHCEADDVO	d	1 ZONE, UNIT, RIBBED PLATE, TOWNGAS, 400X900X700
589333	MCHCEADDVO	d	1 ZONE, UNIT, RIBBED PLAT, C-BOARD, TOWNGAS, 400X900X700
589556	MCHAFADDPO	e	1 ZONE, UNIT, SMOOTH PLATE, 400X900X800
589557	MCHAFADDPO	e	1 ZONE, UNIT, SMOOTH PLATE, C-BOARD, 400X900X800
589564	MCHCFADDPO	e	1 ZONE, UNIT, RIBBED PLATE, 400X900X800
589565	MCHCFADDPO	e	1 ZONE, UNIT, RIBBED PLATE, C-BOARD, 400X900X800

Continued on next page.

Appliances full module:

PNC	Factory Model	Ref.	Description
588533	MBHMBBHOPO	f	2 ZONES, TOP, SMOOTH PLATE, C-BOARD, 800X850X250
588537	MBHNBBHOPO	f	2 ZONES, TOP, RIBBED PLATE, C-BOARD, 800X850X250
588541	MBHOBBHOPO	f	2 ZONES, TOP, MIXED PLATE, C-BOARD, 800X850X250
593108	MBHMBBHOVO	f	2 ZONES, TOP, SMOOTH PLATE, C-BOARD, TOWNGAS, 800X850X250
593110	MBHNBBHOVO	f	2 ZONES, TOP, RIBBED PLATE, C-BOARD, TOWNGAS, 800X850X250
593111	MBHOBBHOVO	f	2 ZONES, TOP, MIXED PLATE, C-BOARD, TOWNGAS, 800X850X250
589094	MCHMAAHOPO	g	2 ZONES, TOP, SMOOTH PLATE, 800X900X250
589095	MCHMABHOPO	g	2 ZONES, TOP, SMOOTH PLATE, C-BOARD, 800X900X250
589102	MCHNAAHOPO	g	2 ZONES, TOP, RIBBED PLATE, 800X900X250
589103	MCHNABHOPO	g	2 ZONES, TOP, RIBBED PLATE, C-BOARD, 800X900X250
589110	MCHOAAHOPO	g	2 ZONES, TOP, MIXED PLATE, 800X900X250
589111	MCHOABHOPO	g	2 ZONES, TOP, MIXED PLATE, C-BOARD, 800X900X250
593320	MCHMAAHOVO	g	2 ZONES, TOP, SMOOTH PLATE, TOWNGAS, 800X900X250
593321	MCHMABHOVO	g	2 ZONES, TOP, SMOOTH PLATE, C-BOARD, TOWNGAS, 800X900X250
593324	MCHNAAHOVO	g	2 ZONES, TOP, RIBBED PLATE, TOWNGAS, 800X900X250
593325	MCHNABHOVO	g	2 ZONES, TOP, RIBBED PLATE, C-BOARD, TOWNGAS, 800X900X250
593326	MCHOAAHOVO	g	2 ZONES, TOP, MIXED PLATE, TOWNGAS, 800X900X250
593327	MCHOABHOVO	g	2 ZONES, TOP, MIXED PLATE, C-BOARD, TOWNGAS, 800X900X250
588668	MBHBGBHDPO	h	2 ZONES, UNIT, SMOOTH PLATE, C-BOARD, 800X850X700
588672	MBHDGBHDPO	h	2 ZONES, UNIT, RIBBED PLATE, C-BOARD, 800X850X700
588676	MBHFGBHDPO	h	2 ZONES, UNIT, MIXED PLATE, C-BOARD, 800X850X700
593113	MBHBGBHDVO	h	2 ZONES, UNIT, SMOOTH PLATE, C-BOARD, TOWNGAS, 800X850X700
593115	MBHDGBHDVO	h	2 ZONES, UNIT, RIBBED PLATE, C-BOARD, TOWNGAS, 800X850X700
593116	MBHFGBHDVO	h	2 ZONES, UNIT, MIXED PLATE, C-BOARD, TOWNGAS, 800X850X700
589538	MCHBEAHDPO	k	2 ZONES, UNIT, SMOOTH PLATE, 800X900X700
589539	MCHBEBHDPO	k	2 ZONES, UNIT, SMOOTH PLATE, C-BOARD, 800X900X700
589546	MCHDEAHDPO	k	2 ZONES, UNIT, RIBBED PLATE, 800X900X700
589547	MCHDEBHDPO	k	2 ZONES, UNIT, RIBBED PLATE, C-BOARD, 800X900X700
589550	MCHFEAHDPO	k	2 ZONES, UNIT, MIXED PLATE, 800X900X700
589551	MCHFEBHDPO	k	2 ZONES, UNIT, MIXED PLATE, C-BOARD, 800X900X700
593330	MCHBEAHDVO	k	2 ZONES, UNIT, SMOOTH PLATE, TOWNGAS, 800X900X700
593331	MCHBEBHDVO	k	2 ZONES, UNIT, SMOOTH PLATE, C-BOARD, TOWNGAS, 800X900X700
593334	MCHDEAHDVO	k	2 ZONES, UNIT, RIBBED PLATE, TOWNGAS, 800X900X700
593335	MCHDEBHDVO	k	2 ZONES, UNIT, RIBBED PLATE, C-BOARD, TOWNGAS, 800X900X700
593336	MCHFEAHDVO	k	2 ZONES, UNIT, MIXED PLATE, TOWNGAS, 800X900X700
593337	MCHFEBHDVO	k	2 ZONES, UNIT, MIXED PLATE, C-BOARD, TOWNGAS, 800X900X700
589558	MCHBFAHDPO	l	2 ZONES, UNIT, SMOOTH PLATE, 800X900X800
589559	MCHBFBHDPO	l	2 ZONES, UNIT, SMOOTH PLATE, C-BOARD, 800X900X800
589566	MCHDFAHDPO	l	2 ZONES, UNIT, RIBBED PLATE, 800X900X800
589567	MCHDFBHDPO	l	2 ZONES, UNIT, RIBBED PLATE, C-BOARD, 800X900X800
589570	MCHFFAHDPO	l	2 ZONES, UNIT, MIXED PLATE, 800X900X800
589571	MCHFFBHDPO	l	2 ZONES, UNIT, MIXED PLATE, C-BOARD, 800X900X800

Page Index

4	Mechanical components 1 zone
6	Components Top
8	Mechanical Modul 2 zones
10	Mechanical Modul for Units
12	Gas heating system
14	Ignition Control

Last Updates

Ed. 12/2015
Ed. 05/2016
Ed- 04/2017

Page

all
all
10

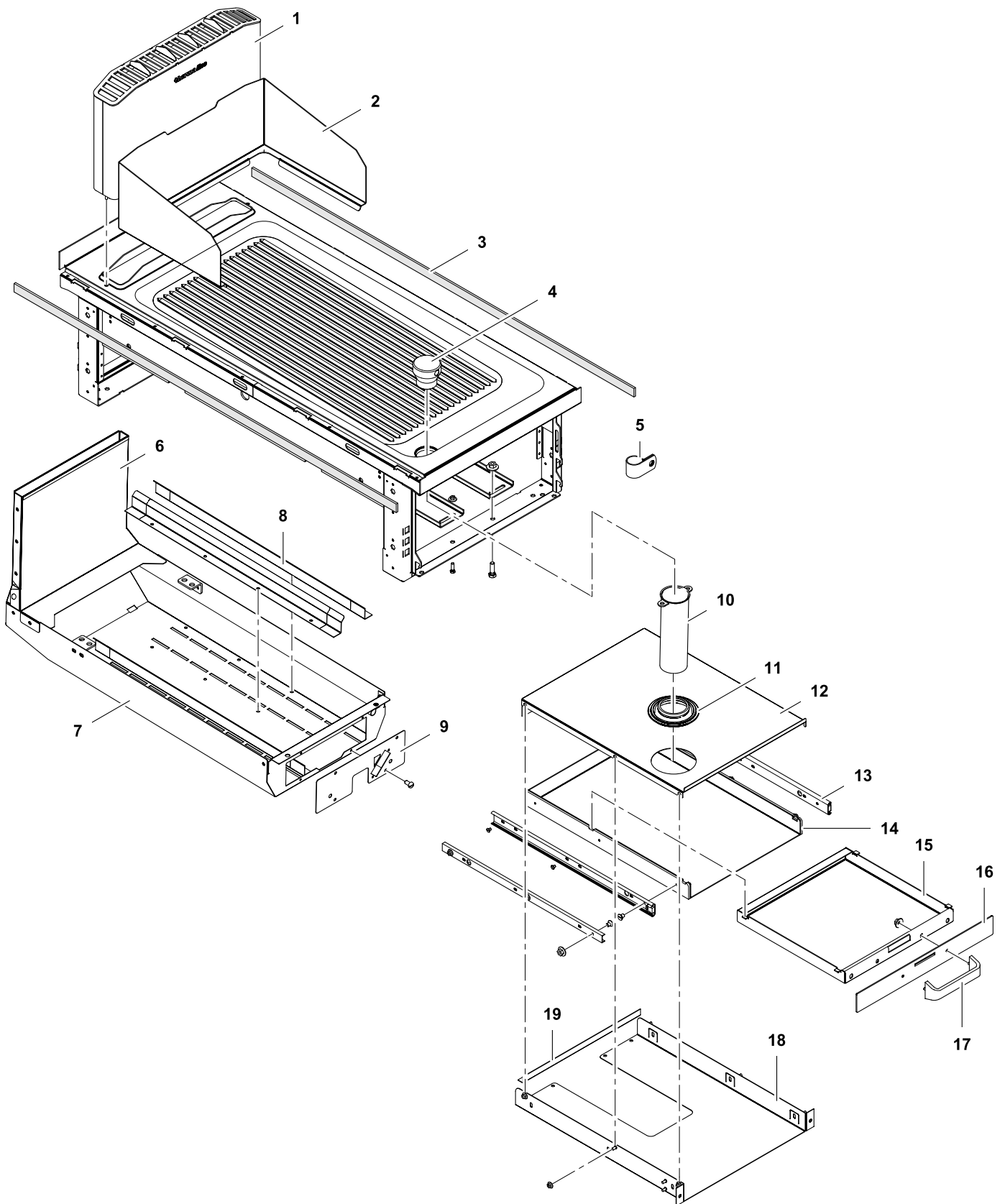

1	Alias	Code	Bezeichnung	Description	Ref.	Valid from Serial N°
1	82.4044.01		Kamin Breite 400	Chimney width 400	a b c d e	
2	82.4292	0G7025	Fettabschirmblech	Grease protection	a b c d e	
3	82.7464	0C2496	Dichtband	Sealing tape	all types	
4	82.7025		Zapfen	Tap	all types	
5	1 115 1635	0T1791	Abschirmschelle	Shield clampe	all types	
6	82.4278	*	Kaminhaube vorne	Chimney frontal part	a b c d e	
7	82.4277	*	Brennkammer	Combustion chamber	a b c d e	
8	82.4039	*	Leitblech Brennkammer 4Stk	Guide plate combustion chamber 4pcs	a b c d e	
9	82.4038		Abdeckblech Brennkammer	Cover plate combustion chamber	a b c d e	
10	82.7155		Ablaufrohr zu Schublade	Drain pipe to drawer	a b	
	82.7335	0G7028	Ablaufrohr zu GN-Schale	Drain pipe to GN-Container	c d e	
11	82.2224	0C6200	Dichtungsmanschette	Gasket	all types	
12	82.4280.06		Schubladendeckel	Lid to drawer	a b	
13	82.7201	0G6687	Accuride-Schiene	Accuride-Rail	a b	
14	82.4284.02	0G7030	Schubladenhalter	Drawer holder	a b	
15	82.4281.02	0G7031	Schublade	Drawer	a b	
16	82.2279	0G7032	Frontblech Schublade	Front panel drawer	a b	
	82.2941		Frontblech Schublade	Front panel drawer	a b	7011...
17	82.2209	0G7033	Handgriff	Handle	a b	
18	82.4279	0G7034	Schubladenfassung	Drawer support	a b	
	82.2942		Schubladenfassung	Drawer support	a b	7011...
19	82.4373	0G7035	Verstärkung Schublade	Reinforcement for drawer	a b	
	82.2944		Verstärkung Schublade	Reinforcement for drawer	a b	7011...

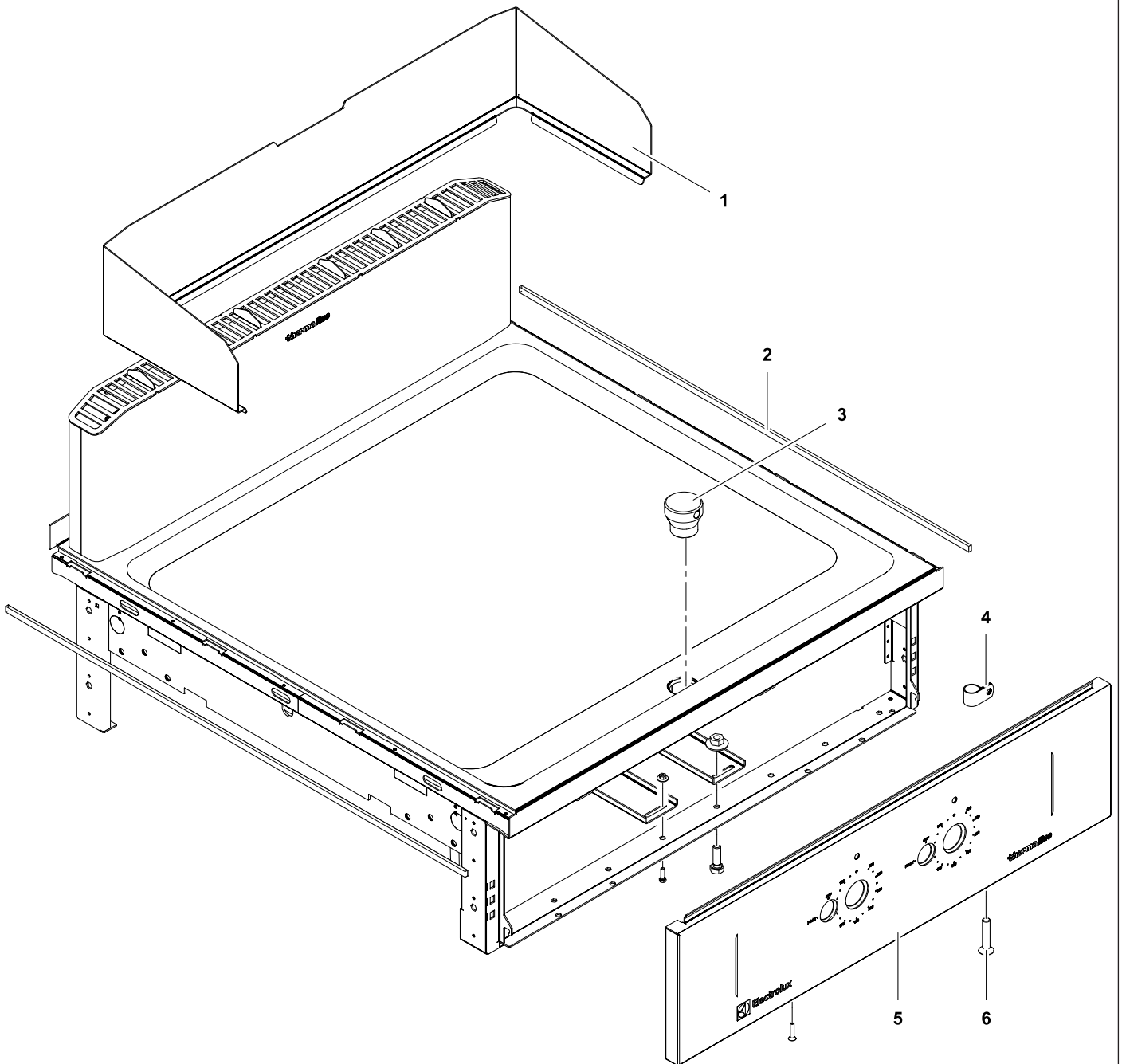

2	Alias	Code	Bezeichnung	Description	Ref.	Valid from Serial N°
1	82.4292	0G7025	Fettabschirmblech 400	Grease protection 400	a b c d e	
	82.4304	0G7039	Fettabschirmblech 800	Grease protection 800	f g h k l	
2	82.7464	0C2496	Dichtband	Sealing tape	all types	
3	82.7025		Zapfen	Tap	all types	
4	1 115 1635	0T1791	Abschirmschelle	Shield clampe	all types	
5	82.1027.08	*	Bedienblende Fry Top 1/2M G 400	Control panel Fry Top 1/2M G 400	d e	
	82.1027.28	*	Bedienblende Fry Top 1/2M G 400 mit Schublade	Control panel Fry Top 1/2M G 400 with drawer	b	
	82.1049.08	*	Bedienblende Fry Top 1/2M G 400 mit Schublade	Control panel Fry Top 1/2M G 400 with drawer	a	
	82.1049.74	*	Bedienblende Fry Top 1/2M G 400	Control panel Fry Top 1/2M G 400	c	
	82.1027.10	*	Bedienblende Fry Top 1M G 800	Control panel Fry Top 1M G 800	k l	
	82.1027.29	*	Bedienblende Fry Top 1M G 800 mit Schublade	Control panel Fry Top 1M G 800 with drawer	g	
	82.1049.13	*	Bedienblende Fry Top 1M G 800 mit Schublade	Control panel Fry Top 1M G 800 with drawer	f	
	82.1049.75	*	Bedienblende Fry Top 1M G 800	Control panel Fry Top 1M G 800	h	
6	1 701 1072	0G6833	Senkschraube M5x25	Countersunk screw M5x25	all types	

* Components on demand
* Teile auf Anfrage

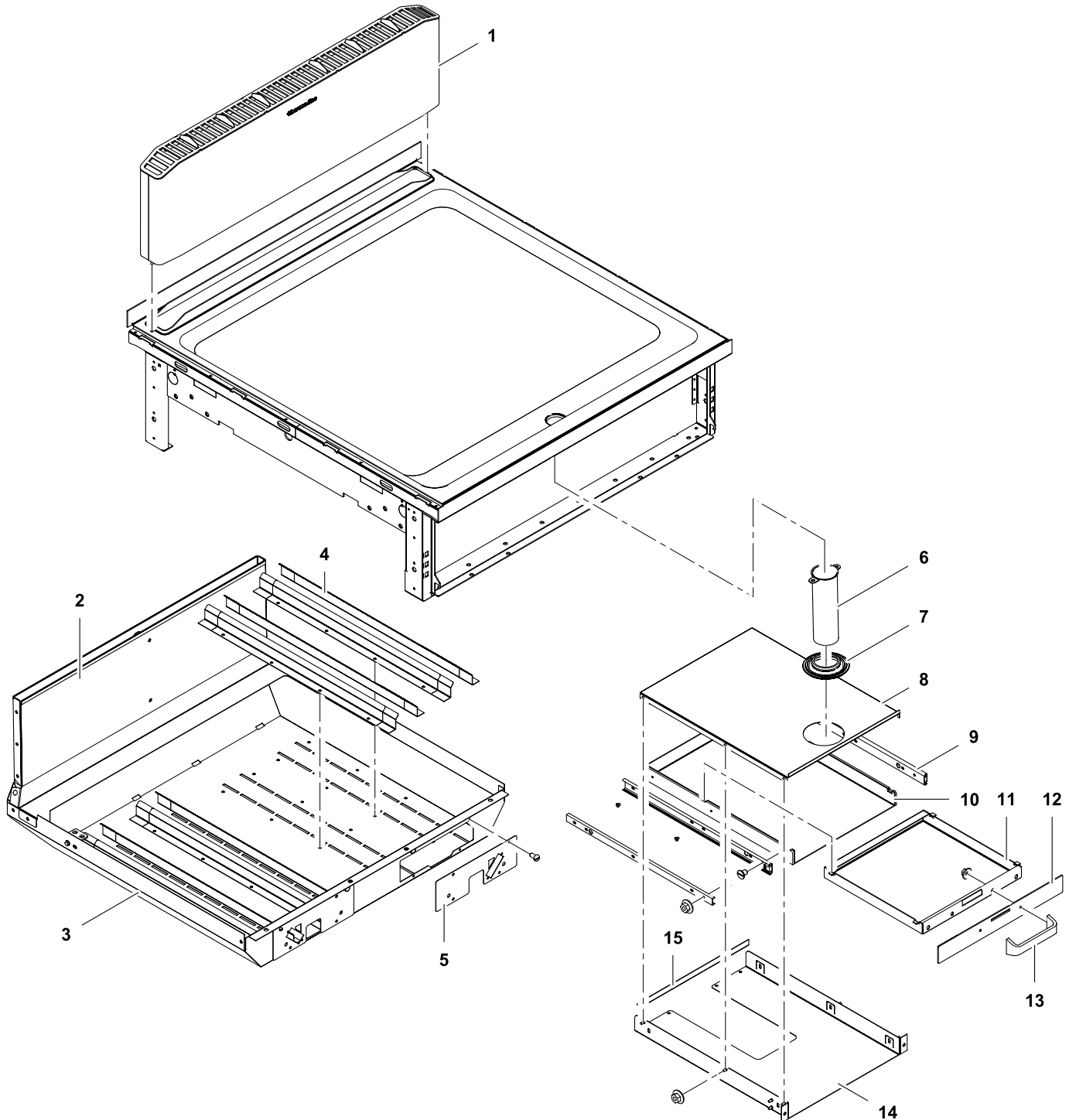

3	Alias	Code	Bezeichnung	Description	Ref.	Valid from Serial N°
1	82.4044.03		Kamin Breite 800	Chimney width 800	f g h k l	
2	82.4036	*	Kaminhaube vorne	Chimney frontal part	f g h k l	
3	82.4035	*	Brennkammer	Combustion chamber	f g h k l	
4	82.4039	*	Leitblech Brennkammer 8Stk.	Guide plate combustion chamber 8pcs	f g h k l	
5	82.4038		Abdeckblech Brennkammer	Cover plate combustion chamber	f g h k l	
6	82.7155		Ablaufrohr zu Schublade	Drain pipe to drawer	f g USA	
	82.7335	OG7028	Ablaufrohr zu GN-Schale	Drain pipe to GN-Container	h k l	
7	82.2224	OC6200	Dichtungsmanschette	Gasket	all types	
8	82.4280.02		Schubladendeckel	Lid to drawer	f g	
	82.0101.11		Deckel zu Korpus	Lid to corpus	h k l	
9	82.7201	OG6687	Accuride-Schiene	Accuride-Rail	f g	
10	82.4284.02	OG7030	Schubladenauszug	Drawer slide	f g	
11	82.4281.02	OG7031	Schublade	Drawer	f g	
12	82.2279	OG7032	Frontblech Schublade	Front panel drawer	f g	
	82.2941		Frontblech Schublade	Front panel drawer	f g	7011...
13	82.2209	OG7033	Handgriff	Handle	f g	
14	82.4279	OG7034	Schubladenfassung	Drawer support	f g	
	82.2942		Schubladenfassung	Drawer support	f g	7011...
15	82.4373	OG7035	Verstärkung Schublade	Reinforcement for drawer	f g	
	82.2944		Verstärkung Schublade	Reinforcement for drawer	f g	7011...

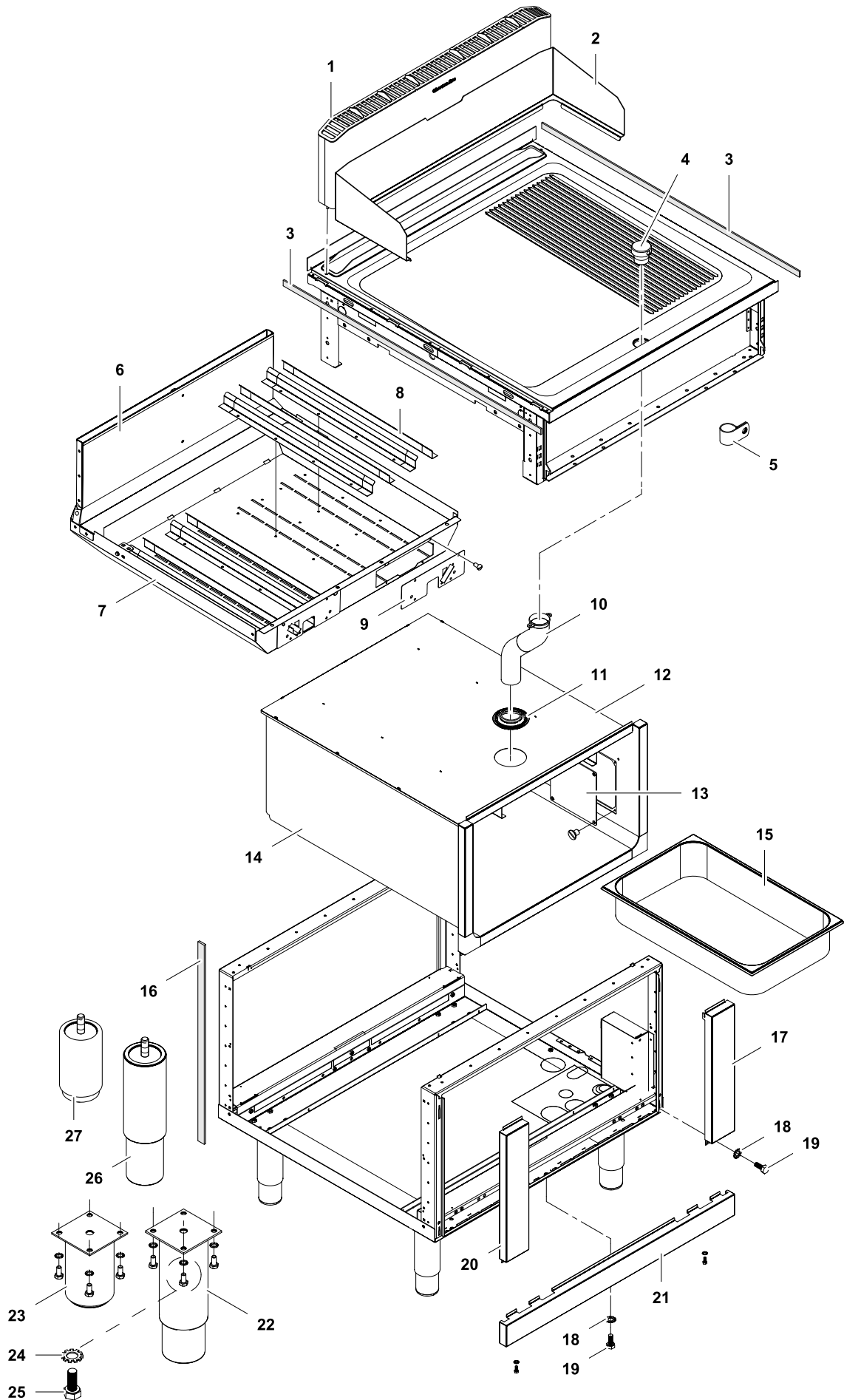

4	Alias	Code	Bezeichnung	Description	Ref.	Valid from Serial N°
1	82.40440.01 82.4044.03		Kamin Breite 400 Kamin Breite 800	Chimney width 400 Chimney width 800	a b c d e f g h k l	
2	82.4292 82.4304	OG7025 OG7039	Fettabschirmhaube Breite 400 Fettabschirmhaube Breite 800	Grease protection width 400 Grease protection width 800	a b c d e f g h k l	
3	82.7464	OC2496	Dichtband	Sealing tape	all types	
4	82.7025		Zapfen	Tap	all types	
5	1 115 1635	OT1791	Abschirmschelle	Shield clampe	all types	
6	82.4278 82.4036	* *	Kaminhaube vorne Kaminhaube vorne	Chimney frontal part Chimney frontal part	a b c d e f g h k l	
7	82.4277 82.4035	* *	Brennkammer Brennkammer	Combustion chamber Combustion chamber	a b c d e f g h k l	
8	82.4039 82.4039	* *	Leitblech Brennkammer 4Stk Leitblech Brennkammer 8Stk.	Guide plate combustion chamber 4pcs Guide plate combustion chamber 8pcs	a b c d e f g h k l	
9	82.4038		Abdeckblech Brennkammer	Cover plate combustion chamber	all types	
10	82.7335	OG7028	Ablaufrohr zu GN-Schale	Drain pipe to GN-Container	c d e h k l	
11	82.2224	OC6200	Dichtungsmanschette	Gasket	all types	
12	82.0101.05 82.0101.11	OG7044	Deckel zu Korpus Deckel zu Korpus	Lid to corpus Lid to corpus	c d e h k l	
13	82.0223.01	OG6757	Deckel Servicefenster	Cover service opening	c h k l	
14	82.2436.02 82.0220.04 82.2436.09 82.0220.11	OG7049 OG7047 OG7046	Korpus Breite 400 NHC Korpus Breite 400 Korpus Breite 800 NHC Korpus Breite 800	Corpus width 400 NHC Corpus width 400 Corpus width 800 NHC Corpus width 800	c d e h k l	
15	82.7333 1 110 1355	OG7382 OS1733	1/3 GN-Schale 1/1 GN-Schale	1/3 GN-Bowl 1/1 GN-Bowl	c d e h k l	
16	82.7464	OC2496	Dichtband seitlich	Sealing tape sideways	c d e h k l	
17	82.1041.03		Korpusabdeckung rechts	Frontal cover right	k l	
18	1 701 7002	OG2923	Fächerscheibe M5	Fan washer M5	all types	
19	1 701 2579	OG4020	Schraube 6kt M5x16	Hex screw M5x16	all types	
20	82.1042.03		Korpusabdeckung links	Frontal cover left	k l	
21	82.1140.04 82.1140.24 82.1140.08 82.1140.28	OG7122 OG7469 OG7288	Anschlussdeckel H66 / B400 Anschlussdeckel H166 / B400 Anschlussdeckel H66 / B800 Anschlussdeckel H166 / B800	Lower panel H66 / W400 Lower panel H166 / W400 Lower panel H66 / W800 Lower panel H166 / W800	c d e h k l	
22	86.0001	OG5391	Fuss 2" 200mm	Foot 2" 200mm	c d h k	
23	86.2385	OG6140	Fuss 2" 100mm	Foot 2" 100mm	e l	
24	1 701 5051	OG6753	Fächerscheibe M6	Fan washer M6	all types	
25	1 701 2600	OKT919	Schraube 6kt M6x12	Hex screw M6x12	all types	
26	82.0350.01		Fuss M10 200mm	Foot M10 200mm	c d h k	7141...
27	82.0350.02		Fuss M10 100mm	Foot M10 100mm	e l	7141...

001 - DETAIL ZÜNDBRENNER

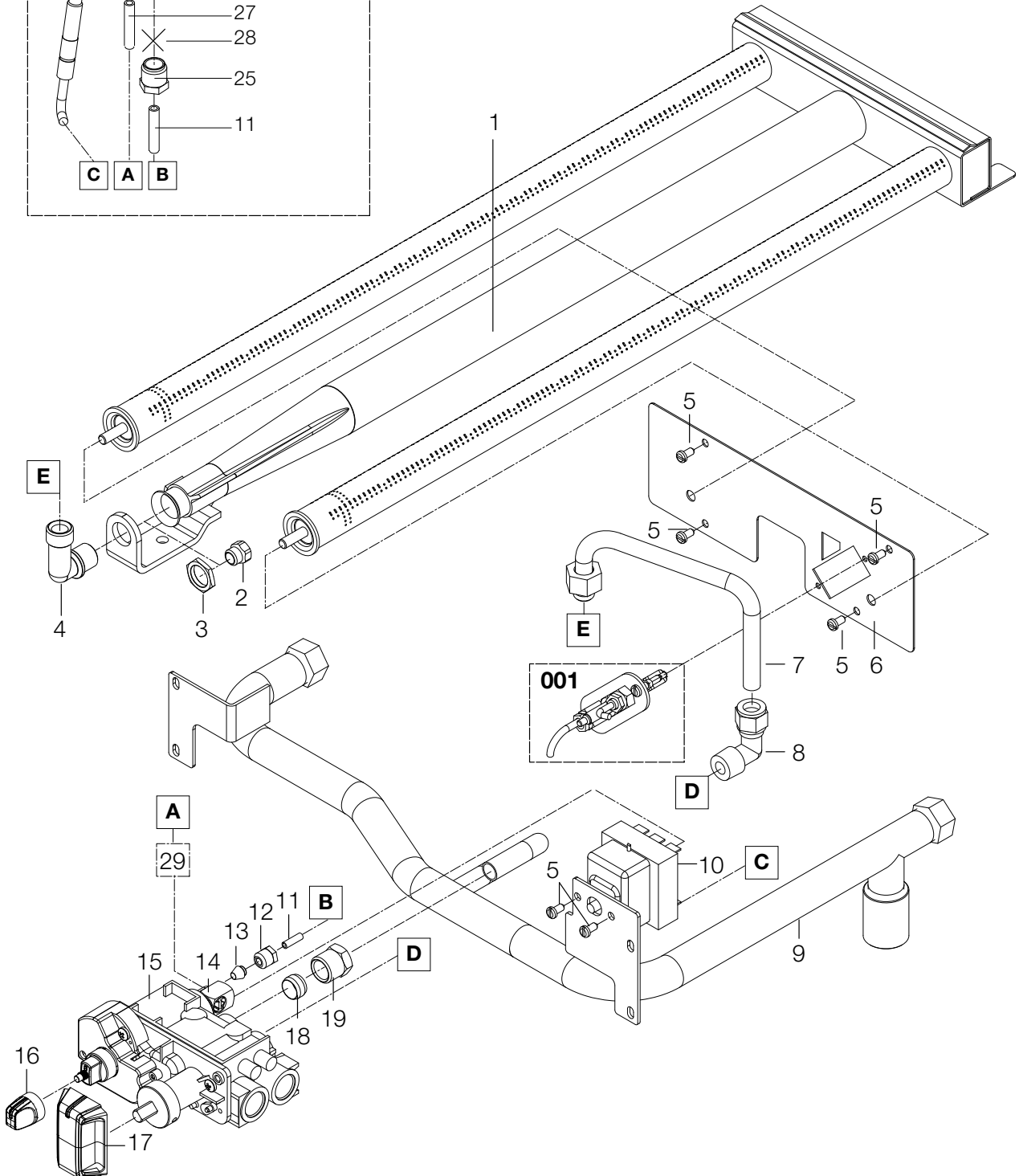
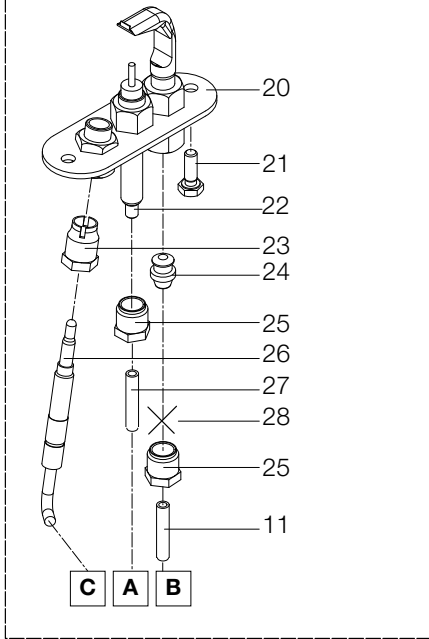

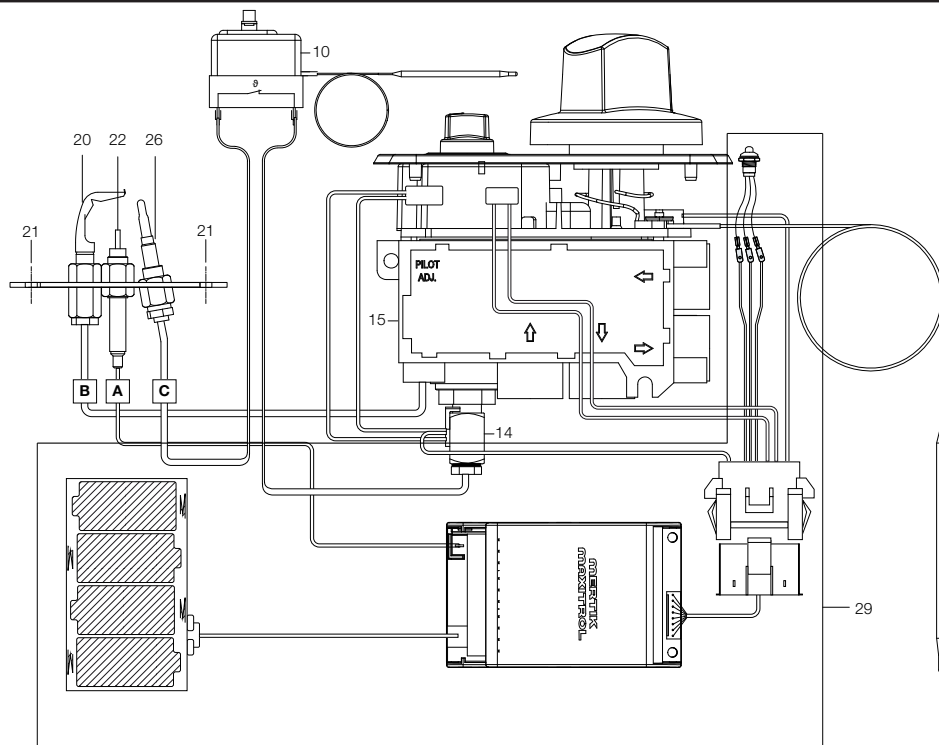

5	Alias	Code	Bezeichnung	Description	Ref.	Valid from Serial N°
1	82.7038		Brenner 10 kW	Burner 10 kW	all types	
2	See nozzle list	-	Düse Hauptbrenner	Main burner nozzle	all types	
3	72.7748	020997	Gegenmutter	Counternut	all types	
4	72.7102	OG3635	Düsenträger	Nozzle holder	all types	
5	1 701 7504		Blechschraube 4.2x9.5	Tapping screw 4.2x9.5	all types	
6	82.4038		Abdeckblech Brennkammer	Cover plate combustion chamber	all types	
7	82.4290	*	Gasleitung Brenner	Gas line burner	a b c d e	
	82.4042.01	*	Gasleitung Brenner rechts	Gas line burner right	f g h k l	
	82.4042.02	*	Gasleitung Brenner links	Gas line burner left	f g h k l	
8	82.7046		L-Verschraubung G3/8" D10	L-Fitting G3/8" D10	all types	
9	82.4069	*	Gasrampe komplett 400	Gas line complete 400	a b c d e	
	82.4041	*	Gasrampe komplett 800	Gas line complete 800	f g h k l	
10	1 115 1622		Sicherheitstemperaturbegrenzer	Safety temperature limiter	all types	
11	82.4291	*	Gasleitung Zündleitung	Gas line ignition wire	a b c d e	
	82.4043.01	*	Gasleitung Zündleitung rechts	Gas line ignition wire right	f g h k l	
	82.4043.02	*	Gasleitung Zündleitung links	Gas line igniton wire left	f g h k l	
12	72.7742		Verbindungsanschluss	Connection port	all types	
13	1 701 2757	OG2960	Klemmring D4	Clamp ring D4	all types	
14	82.9087	*	Thermischer Stromunterbrecher GV60 M9x1	Thermocurrent interrupter GV60 M9x1	all types	
15	82.2437	OG7856	Mertik Ventil	Metik valve	all types	
16	82.7003	OG6345	Drehgriff Mertik	Handle Mertik	all types	
17	82.7566	OG7833	Drehgriff	Handle	all types	
18	82.7044	050682	Klemmring D12	Clamp ring D12	all types	
19	82.7045	051950	Verschraubung D12 3/8"	Fitting D12 3/8"	all types	
20	1 106 1224		Zündbrenner	Ignition torch	all types	
21	1 701 2503	OG5490	Schraube 6kt M4x8	Hex bolt M4x8	all types	
22	72.7820	059380	Zündkerze	Spark plug	all types	
23	1 106 1236	0C0121	Thermoelementschraube	Thermocouple screw	all types	
24	72.7799		Verbindungsstück D4	Connection piece	all types	
25	72.7759	057960	Anschluss-Elektrode	Connection electrode	all types	
26	72.7793	0C3162	Thermoelement	Thermocouple	all types	
27	82.7428		Gasleitung Zündbrenner	Gas line Ignition Burner	all types	
28	See nozzle list	-	Düse Zündbrenner	Nozzle Ignition burner	all types	
29	82.7561	OG7885	Kit Gassteuerung Mertik	Kit gas control Mertik	all types	

* Components on demand
* Teile auf Anfrage



Electrolux

thermaline 80 / 85 / 90 Nozzle list / Düsentabelle

Appliance:

Nominal heat input:

FRY TOP

10 kW / 20 kW

Factory Model

MxHxxxxPx

Range:

800 / 850 / 900 82.8091.04

Doc N°

Town Gas	GAS TYPE	COUNTRY	NOMINAL PRESS.	GAS TYPE Testgas	CATEGORIES	Pressure Regulator ±1%	Nozzle C main burner (Abb. 2)			Small adjusting nozzle			Nozzle F ignition burner (Abb. 3)			Aeration adj. PILOT BURNER X (mm)	Aeration adj. MAIN BURNER D (mm) (Abb. 1)	Gas consumption 956.5 mbar Baro / 20 °C Sursee Allmendstrasse			
							Type	mm	Alias N°	Spare Part N°	mm	Alias N°	Spare Part N°	N°	Alias N°			Spare Part N°	Gas Consum.	Min.	Nominal-value
Natural Gas	1	G 110		G110	1a	-	5.40	72.7801.46	0C0449	-	-	50	72.7800.04	059356	-	15	2.58 m3/h	41.91	44.11	46.32	
	2	G 120	DK, SE	G120	1b	-	4.70	72.7801.37	0G6602	-	-	50	72.7800.04	059356	-	15	2.30 m3/h	37.43	39.40	41.37	
	3	Natural Gas H	HU	25	G20	2H	-	2.30	72.7801.40	0A2081	-	-	27	72.7800.02	059215	-	14	1.06 m3/h	17.05	17.94	18.84
					G25.1	2S	-	2.55	72.7801.41	059529	-	-	27	72.7800.02	059215	-	13	1.23 m3/h	19.73	20.77	21.81
	5		AT, CH, DK, EE, ES, FI, GB, GR, IE, IT, LV, NO, PT, SE, SI, SK, BG, CZ, HR, LT, RO, TR, CZ	20	G20	2H	-	2.40	72.7801.16	0A2104	-	-	27	72.7800.02	059215	-	15	1.06 m3/h	17.05	17.94	18.84
	6	Natural Gas E	DE, LU, PL	20	G20	2E	-	2.40	72.7801.16	0A2104	-	-	27	72.7800.02	059215	-	15	1.06 m3/h	17.05	17.94	18.84
	7	Natural Gas H/L Pressure Couple	BE, FR	20/25	G20	2E+	-	2.40	72.7801.16	0A2104	-	-	27	72.7800.02	059215	-	15	1.06 m3/h	17.05	17.94	18.84
					G25	2L	-	2.50	72.7801.18	059382	-	-	27	72.7800.02	059215	-	14	1.23 m3/h	19.73	20.77	21.81
	9	Natural Gas L	NL	25	G25	2L	-	2.65	72.7801.32	0A2174	-	-	27	72.7800.02	059215	-	14	1.23 m3/h	19.83	20.87	21.91
	10	Natural Gas LL	DE	20	G25	2LL	-	1.50	72.7801.47	059384	-	-	14	72.7800.01	059216	-	17	0.78 Kg/h	6.40	6.74	7.07
12																					
Liquid Gas	Butan/Propan	CZ, CY, DK, EE, FI, HU, LV, LT, MT, NL, NO, SE, SI, SK, BG, HR, IS, RO, TR	30	G30/31	3B/P	-	1.55	72.7801.04	0A2103	-	-	14	72.7800.01	059216	-	17	0.79 Kg/h	4.91	5.17	5.43	
																					13
	14	Butan/Propan Pressure Couple	AT, CH, DE	50	G31	3+	-	1.40	72.7801.13	0A2082	-	-	14	72.7800.01	059216	-	17	0.79 Kg/h	4.85	5.11	5.36
15	BE, CH, ES, FR, GB, GR, IE, IT, PT, LT, SI, CZ, EE, LV, SK	28-30 / 37	50	G30/31	3+	-	1.60	72.7801.29	0A2089	-	-	14	72.7800.01	059216	-	21	0.79 Kg/h	4.95	5.21	5.47	

Abb. 1



Abb. 2



Abb. 3

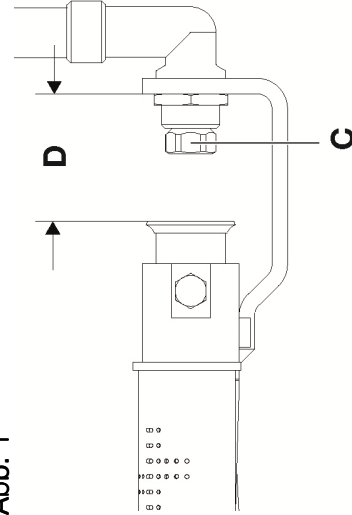
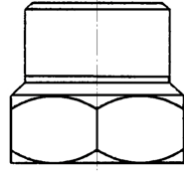