

# Nomenclature Corps / Body Parts list / Stückliste Körper / Nomenclatura Corpo / Nomenclatura Cuerpo / Specifikation huvuddel

Rep Item Pos.	Qté Qty Mge	Code Part N° Teile-Nr	Désignation	Description	Bezeichnung
1	1	OD5412	Manchon	Sleeve	Hülse
2	1	OD2662	Joint torique 15,54x2,62 (jeu x 5)	15.54x2.62 O-ring (set x 5)	O-Ring 15,54x2,62 (5-er Satz)
3	1	OD5413	Came	Cam	Nocke
4	4	OD6754	Vis M4x12 (jeu x 10)	M4x12 screw (set x 10)	Schraube M4x12 (10-er Satz)
5	2	OD5414	Vis PTWN 1412 K30/16 (jeu x 10)	1412 K30/16 PTWN screw (set x 10)	Schraube PTWN 1412 K30/16 (10-er Satz)
6	1	OD6620	Minirupteur avec galet	Micro-switch with wafer	Mikroschalter mit Rolle
7	1	OD5415	Support micro rupteur	Micro-switch support	Halterung Mikroschalter
8	1	OD7860	Goupille G06 5x25 (jeu x 10)	G06 5x25 pin (set x 10)	Stift G06 5x25 (10-er Satz)
9	1	OD5997	Arbre K19 équipé	K19 shaft assembly	Welle K19 ausgestattet
10	1	OD5419	Défecteur	Deflector	Abweiser
11	1	OKI998	Joint à lèvres 28x40x7 (jeu x 5)	28x40x7 lip seal (set x 5)	Simmering 28x40x7 (5-er Satz)
12	1	OD0520	Rondelle de 4 (jeu x 10)	4 washer (set x 10)	4-er U-Scheibe (10-er Satz)
13	1	OD3567	Cosse laiton terre (jeu x 5)	Brass earth cable terminal (set x 5)	Erdungsanschluss Bronze (5-er Satz)
14	1	voir S3	Broche	Spindle	Stift
15	1	OD0396	Goupille G05 5x20 (jeu x 10)	G05 5x20 pin (set x 10)	Stift G05 5x20 (10-er Satz)
16	1	OKQ479	Goupille G01 3x16 (jeu x 10)	G01 3x16 pin (set x 10)	Stift G01 3x16 (10-er Satz)
17	1	OD5427	Bouton	Button	Taster
18	1	OD5428	Guide	Guide	Führung
19	1	OD5429	Corps	Body	Gehäuseoberteil
20	1	OD6439	Support PSA complet	Complete PSA support	Halterung PSA komplett
21	1	OD7492	Bouton ég	Button assembly	Taster ausgestattet
102	1	Voir S30	Axe rotatif	Pin	Achse
103	2	OD7859	Circlips 8E ( j x 10 )	Circlip 8E ( set x 10 )	Sicherungsring 8E ( 10-er Satz )
104	2	OD7857	Coussinet ( j x 10 )	Bearing ( set x 10 )	Rollager (10-er Satz )
105	2	OD7858	Circlips 6E ( j x 10 )	Circlip 6E ( set x 10 )	Sicherungsring 6E ( 10-er Satz )
106	1	OD3043	Bouchon ( j x 10 )	Cap ( set x 10 )	Stopfen (10er- Satz )
S1		OD5430	Manchon + guide complet	Complete sleeve + guide	Hülse + Führung komplett
S2		OD5431	Support microrupteur équipé	Micro-switch support assembly	Halterung Mikroschalter ausgestattet
S3		OD5432	Broche équipée	Spindle assembly	Stift ausgestattet
S4		OD5433	Corps équipé	Body assembly	Gehäuseoberteil ausgestattet
S30		OD7856	Axe rotatif ég.	Assembly pin	Achse ausgestattet

N° N. Ref	Qtà Cad Kvant	Cod Código Kod	Designazione	Descripción	Beskrivning
1	1	OD5412	Giunto	Manguito	Spak
2	1	OD2662	Guarnizione torica 15,54x2,62 (set x 5)	Junta tórica 15,54x2,62 (juego x 5)	O-ring 15,54x2,62 (sats x 5)
3	1	OD5413	Camma	Leva	Kam
4	4	OD6754	Vite M4x12 (set x 10)	Tornillo M4x12 (juego x 10)	Skruv M4x12 (sats x 10)
5	2	OD5414	Vite PTWN 1412 K30/16 (set x 10)	Tornillo PTWN 1412 K30/16 (juego x 10)	Skruv PTWN 1412 K30/16 (sats x 10)
6	1	OD6620	Microinterruttore con rotella	Microinterruptor de rodillo	Minikontaktor med brytkontakt
7	1	OD5415	Supporto microinterruttore	Soporte microinterruptor	Stöd minikontaktor
8	1	OD7860	Spina G06 5x25 (set x 10)	Pasador G06 5x25 (juego x 10)	Stift G06 5x25 (sats x 10)
9	1	OD5997	Albero K19 in dotazione	Árbol K19 equipado	Utrustad axel I K19
10	1	OD5419	Deflettore	Deflector	Detektor
11	1	OKI998	Guarnizione a labbro 28x40x7 (set x 5)	Junta de labios 28x40x7 (juego x 5)	Skårfog 28x40x7 (sats x 5)
12	1	OD0520	Rondella da 4 (Set x 10)	Arandela de 4 (juego x 10)	Bricka, 4 (sats x 10)
13	1	OD3567	Capocorda ottone terra (set x 5)	Terminal latón tierra (juego x 5)	Uttag, mässing, jord (sats x 5)
14	1	voir S3	Mandrino	Pasador	Spindel
15	1	OD0396	Spina G05 5x20 (set x 10)	Pasador G05 5x20 (juego x 10)	Stift G05 5x20 (sats x 10)
16	1	OKQ479	Spina G01 3x16 (set x 10)	Pasador G01 3x16 (juego x 10)	Stift G01 3x16 (sats x 10)
17	1	OD5427	Pulsante	Botón	Knapp
18	1	OD5428	Guida	Guía	Ledskada
19	1	OD5429	Corpo	Cuerpo	Huvuddel
20	1	OD6439	Supporto PSA completo	Soporte PSA completo	Komplett stöd, PSA
21	1	OD7492	Pulsante in dotazione	Botón equipado	Utrustad Knapp
102	1	Voir S30	Asse	Eje	Axel
103	2	OD7859	Anello 8E ( set x 10 )	Circlip 8E ( juego x 10 )	Fjaderring 8E ( sats x 10 )
104	2	OD7857	Cuscinetto ( set x 10 )	Rollager ( juego x 10 )	Rullager ( sats x 10 )
105	2	OD7858	Anello 6E ( set x 10 )	Circlip 6E ( juego x 10 )	Fjaderring 6E ( Sats x 10 )
106	1	OD3043	Tappo ( set x 10 )	Tapon ( juego x 10 )	Propp ( Sats x 10 )
S1		OD5430	Giunto + guida completa	Manguito + guía completa	Spak + komplett ledskena
S2		OD5431	Supporto microinterruttore in dotazione	Soporte microinterruptor equipado	Stöd, utrustad minikontaktor
S3		OD5432	Manicotto in dotazione	Pasador equipado	Utrustad spindel
S4		OD5433	Corpo in dotazione	Cuerpo equipado	Utrustad huvuddel
S30		OD7856	Asse in dotazione	Eje equipado	Utrustad axel

**Vue éclatée Corps / Body exploded view / Explosionszeichnung - Körper /  
Esploso Corpo / Despiece Cuerpo / Sprängskiss huvuddel** \_\_\_\_\_

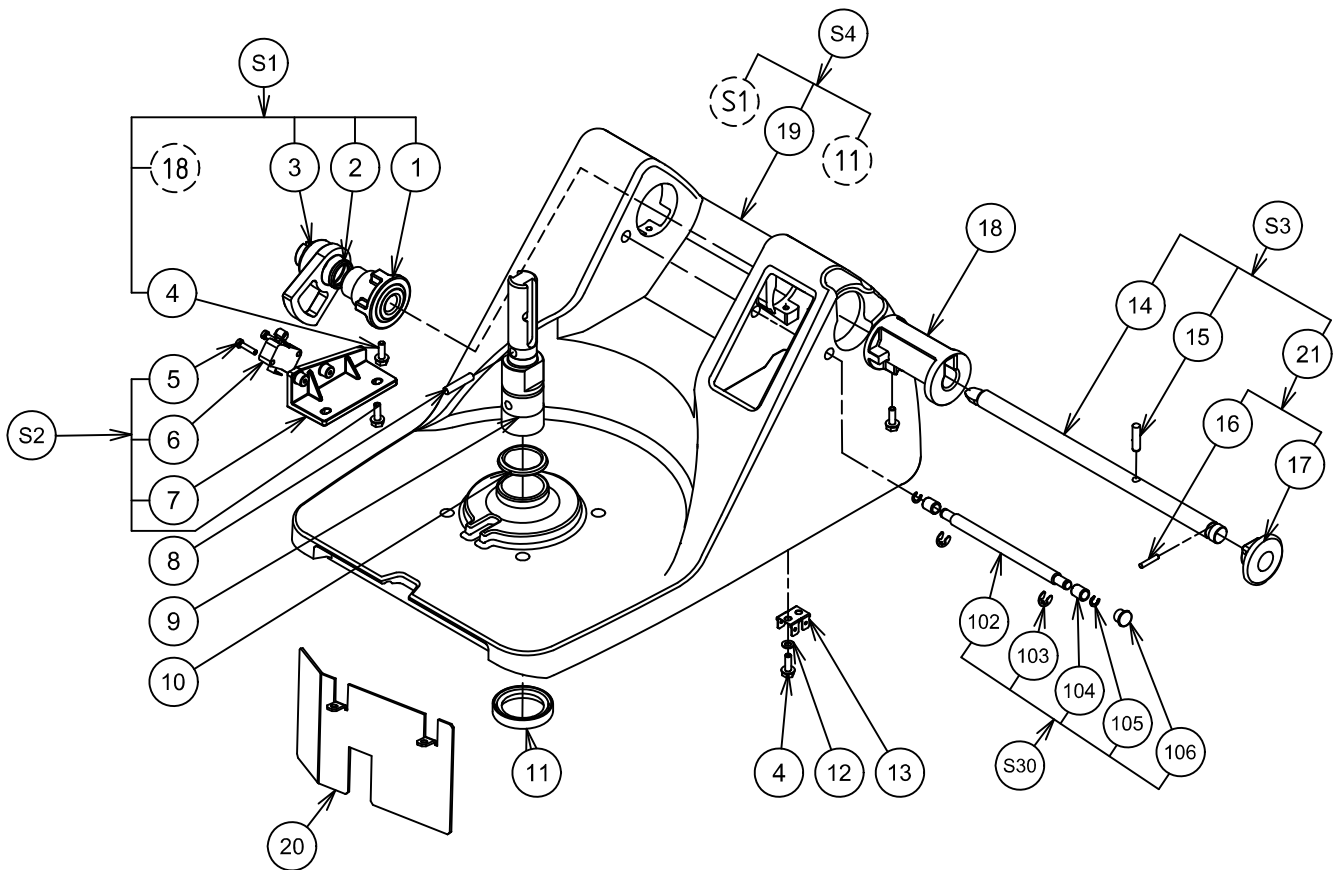

# Nomenclature Moteur / Motor Parts list / Stückliste Motor / Nomenclatura Motore / Nomenclatura Motor / Spezifikation Motor

Rep Item Pos.	Qté Qty Mge	Code Part N° Teile-Nr	Désignation	Description	Bezeichnung
8	1	0D7860	Goupille G06 5x25 (jeu x 10)	G06 5x25 pin (set x 10)	Stift G06 5x25 (10-er Satz)
9	1	voir S7	Arbre k19	K19 shaft	Welle K19
10	1	0D5419	Défecteur	Deflector	Abweiser
11	1	0KI998	Joint à lèvres 28x40x7 (jeu x 5)	G02 6x24 pin (set x 10)	Stift G02 5x24 (10-er Satz)
24	1	0D0571	Goupille G02 6x24 (jeu x 10)	28x40x7 lip seal (set x 5)	Simmering 28x40x7 (5-er Satz)
25	4	0D1017	Vis TRL M6x16 (jeu x 10)	M6x16 TRL screw (set x 10)	Flache Halbrundschrabe M6x16 (10-er Satz)
30	4	0D5144	Joint torique (jeux5)	O-ring (set x 5)	O-ring (10-er Satz)
S5		0D7938	Mot. 1V. Mono 208/240-50Hz- 0.75Kw	K45 Single ph mot1V. 208/240-50Hz- 0.75Kw	K45 Wechselstr.mot.1V 208/240-50Hz-0.75Kw
		0D7939	Mot.2V. Tri 380/440-50/60Hz- 0.9Kw	K45 Three ph mot.2V 380/440-50/60Hz- 0.9Kw	K45 Drehstr.mot.2V 380/440-50/60Hz- 0.9Kw
		0D7940	Mot.2V. Tri 380/440-50/60Hz- 1Kw	K55 Three ph mot.2V 380/440-50/60Hz- 1Kw	K55 Drehstr.mot.2V 380/440-50/60Hz- 1Kw
		0D7941	Mot.2V. Tri 380/440-50/60Hz- 1.2Kw	K70 Three ph mot.2V 380/440-50/60Hz- 1.2Kw	K70 Drehstr.mot.2V 380/440-50/60Hz- 1.2Kw
		0D7942	Mot.VV. Tri 230/400-50Hz-1Kw	K45 Three ph mot.VV 230/400-50Hz-1Kw	K45 Drehstr.mot.VV 230/400-50Hz-1Kw
		0D7943	Mot.VV. Tri 230/400-50Hz-1.3Kw	K55 Three ph mot.VV 230/400-50Hz-1.3Kw	K55 Drehstr.mot.VV 230/400-50Hz-1.3Kw
		0D7944	Mot.VV. Tri 230/400-50Hz-1.5Kw	K70 Three ph mot.VV 230/400-50Hz-1.5Kw	K70 Drehstr.mot.VV 230/400-50Hz-1.5Kw
S7	1	0D5997	Arbre équipé	Shaft assembly	Welle komplett

N° N. Ref	Qtà Cad Kvant	Cod Código Kod	Designazione	Descripción	Beskrivning
8	1	0D7860	Spina G06 5x25 (set x 10)	Pasador G06 5x25 (juego x 10)	Stift G06 5x25 (sats x 10)
9	1	voir S7	Albero K19	Árbol K19	Axel k19
10	1	0D5419	Deflettore	Deflector	Detektor
11	1	0KI998	Guarnizione a labbro 28x40x7 (set x 5)	Junta de labios 28x40x7 (juego x 5)	Skärfog 28x40x7 (sats x 5)
24	1	0D0571	Spina G02 6x24 (set x 10)	Pasador G02 6x24 (juego x 10)	Stift G02 6x24 (sats x 10)
25	4	0D1017	Vite TRL M6x16 (set x 10)	Tornillo TRL M6x16 (juego x 10)	Skruv TRL M6x16 (sats x 10)
30	4	0D5144	Guarnizione torica (set x 5)	Junta tórica 15,54x2,62 (juego x 5)	O-ring 15,54x2,62 (sats x 5)
S5		0D7938	Mot. mono 1V 208/240-50Hz- 0.75Kw	K45 Mot. mono 1V 208/240-50Hz- 0.75Kw	K45 Mot. enfasig1V208/240-50Hz- 0.75Kw
		0D7939	Mot. tri 2V 380/440-50/60Hz- 0.9Kw	K45 Mot. tri 2V 380/440-50/60Hz- 0.9Kw	K45 Mot. tre 2V 380/440-50/60Hz- 0.9Kw
		0D7940	Mot. tri 2V 380/440-50/60Hz- 1Kw	K55 Mot. tri 2V 380/440-50/60Hz- 1Kw	K55 Mot. tre 2V 380/440-50/60Hz- 1Kw
		0D7941	Mot. tri 2V 380/440-50/60Hz- 1.2Kw	K70 Mot. tri 2V 380/440-50/60Hz- 1.2Kw	K70 Mot. tre 2V 380/440-50/60Hz- 1.2Kw
		0D7942	Mot. tri VV 230/400-50Hz- 1Kw	K45 Mot. tri VV 230/400-50Hz- 1Kw	K45 Mot. tre VV 230/400-50Hz- 1Kw
		0D7943	Mot. tri VV 230/400-50Hz- 1.3Kw	K55 Mot. tri VV 230/400-50Hz- 1.3Kw	K55 Mot. tre VV 230/400-50Hz- 1.3Kw
		0D7944	Mot. tri VV 230/400-50Hz- 1.5Kw	K70 Mot. tri VV 230/400-50Hz- 1.5Kw	K70 Mot. tre VV 230/400-50Hz- 1.5Kw
S7	1	0D5997	Gruppo albero	Arbol equipado	Utrustad axel

# Nomenclature Caisson / Casing Parts list / Stückliste Gehäuse / Nomenclatura Cassone / Nomenclatura Carcasa / Spezifikation behållare

Rep Item Pos.	Qté Qty Mge	Code Part N° Teile-Nr	Désignation	Description	Bezeichnung
26	1	0D5592	Passe-fil 9x14x3 (jeu x 10)	9x14x3 grommet (set x 10)	Införingskydd 9x14x3 (sats x 10)
27	1	voir S8	Caisson droit	Straight casing	Höger behållare
28	4	0D6754	Vis M 4x12 (jeu x 10)	M 4x12 screw (set x 10)	Skruv M 4x12 (sats x 10)
29	4	0D0503	Ecrou HU M6 (jeu x10)	Nut HU M6 (set x 10)	Mutter M6 komplette( 10-er satz)
31	4	0D2870	Rondelle CS L6 (jeu x10)	Washer CSL 6 (set x 10)	6-er U-Scheibe (10-er Satz)
32	2	voir S6	Traverse	Cross-member	Riegel siehe
33	4	0D7136	Patin équipé(jeu x 6)	Pad assembly (set x 6)	Skenfot komplett (sats x 6)
34	4	0D3039	Vis TC M6x40 (jeu x10)	M6x40 TC screw (set x 10)	Schraube M6x40 (10-er Satz)
S6		0D7945	Traverse éq.	Cross-member assembly	Utrustad höger behållare
S8		0D7946	Caisson éq.	Straight casing assembly	Riegel siehe

N° N. Ref	Qtà Cad Kvant	Cod Código Kod	Designazione	Description	Bezeichnung
26	1	0D5592	Occhiello 9x14x3 (set x 10)	Pasahilos 9x14x3 (juego x 10)	Införingskydd 9x14x3 (sats x 10)
27	1	voir S8	Cassone destro	Carcasa derecha	Höger behållare
28	4	0D6754	Vite M4x12 (set x 10)	Tornillo M4x12 (juego x 10)	Skruv M 4x12 (sats x 10)
29	4	0D0503	Dado HU M6 (set x 10)	Tuerca HU M6 (juego x 10)	Mutter M6 komplette( 10-er satz)
31	4	0D2870	Rondella CS L6 (set x 10)	Arendela CS L 6 (juego x 10)	6-er U-Scheibe (10-er Satz)
32	2	voir S6	Traversa	Traversano	Riegel siehe
33	4	0D7136	Base ( set x 6)	Patin (juego x 6)	Skenfot komplett (sats x 6)
34	4	0D3039	Vite TC M6x40 (set x 10)	Tornillo TC M6x40 (juego x 10)	Schraube M6x40 (10-er Satz)
S6		0D7945	Gruppo traversa	Traversano equipado	Utrustad höger behållare
S8		0D7946	Cassone destro in dotazione	Carcasa derecha equipada	Riegel siehe

**Vue éclatée Moteur+Caisson / Motor + Casing exploded view / Explosionszeichnung Motor + Gehäuse / Esploso Motore+Cassone / Despiece Motor+Carcasa / Sprängskiss motor+behållare**

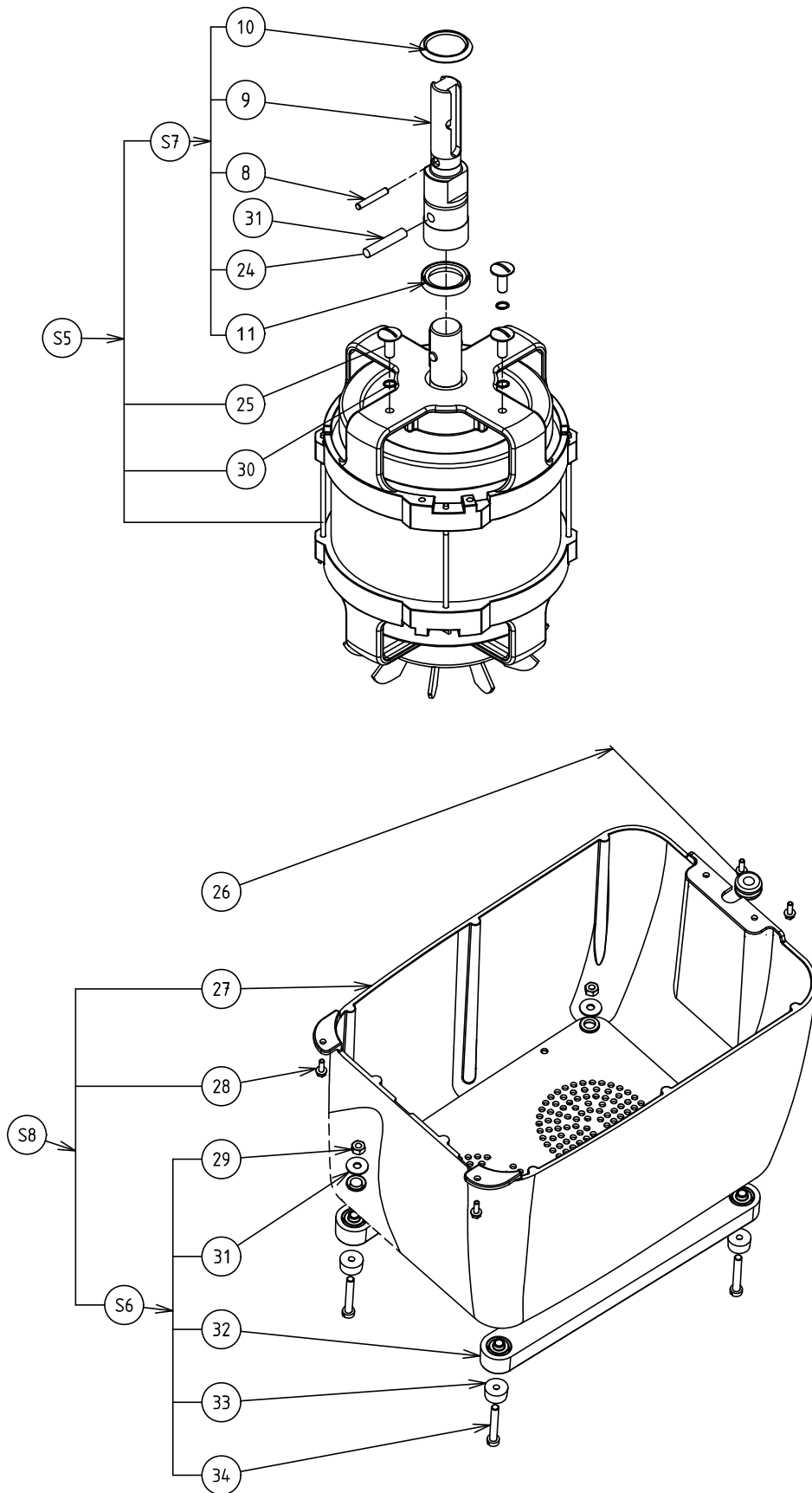

# Nomenclature Couvercle + Cuve / Lid + Bowl Parts list / Stückliste Kessel + Deckel / Nomenclatura Coperchio + Vasca / Nomenclatura Tapa + Cuba / Specifikation lock + skål

Rep Item Pos.	Qté Qty Mge	Code Part N° Teile-Nr	Désignation	Description	Bezeichnung
32	1	voir S8	Poignée de racleur	Scraper handle	Griff Schaber
34	1	voir S8	Racleur de cuve K45	K45 bowl scraper	Schaber Kessel K45
		voir S8	Racleur de cuve K55/K70	K55/K70 bowl scraper	Schaber Kessel K55/K70
35	1	0D5439	Poignée bride de couvercle	Lid clamp handle	Griff Stift Deckel
39	2	0D5442	Cache vis 6p creux (jeu x 10)	6p concave screw cover (set x 10)	Blende Innensechskantschrauben (10-er Satz)
40	2	0D2108	Vis TCHC M5x10 (jeu x 15)	M5x10 TCHC screw (set x15)	Zylinderkopfschraube mit Innensechskant M5x10 (15-er Satz)
41	1	voir S11	Cuve	Bowl	Kessel
42	1	653579	Rotor lisse 4,5 litres	4.5-litre smooth rotor	Rotor glatt 4,5 Liter
	1	653580	Rotor micro dentés 4,5 litres	4.5-litre micro-toothed rotor	Rotor mikroverzahnt 4,5 Liter
	1	653581	Rotor lisse 5 litres	5-litre smooth rotor	Rotor glatt 5 Liter
	1	653582	Rotor micro dentés 5 litres	5-litre micro-toothed rotor	Rotor mikroverzahnt 5 Liter
	1	653583	Rotor lisse 7 litres	7-litre smooth rotor	Rotor glatt 7 Liter
	1	653584	Rotor micro dentés 7 litres	7-litre micro-toothed rotor	Rotor mikroverzahnt 7 Liter
43	1	0D5490	Joint de couvercle	Lid seal	Dichtung Abdeckung
44	1	0D5491	Couvercle 4,5/5,5 litres	5-litre lid	Deckel 5 Liter
	1	0D5492	Couvercle 7 litres	7-litre lid	Deckel 7 Liter
45	2	0D7973	Vis F M3x10 (jeu x 10)	M3x10 F screw (set x 10)	Schraube F M3x10 (10-erSatz)
46	1	voir S13	Bride	Flange	Kesselflansch
47	1	0D1054	Bouchon (jeu x 4)	Plug (set x 4)	Stopfen (4 -er Satz)
S8		0D5493	Racleur cuve couvercle complet K45	K45 complete bowl lid scraper	Schaber Kessel Deckel komplett K45
		0D5494	Racleur cuve couvercle complet K55/K70	K55/K70 complete bowl lid scraper	Schaber Kessel Deckel komplett K55/K70
S10		0D5496	Poignée de cuve équipée	Bowl handle assembly	Kesselgriff ausgestattet
S11		653589	Cuve 4,5 litres complète	Complete 4.5-litre bowl	Kessel 4,5 Liter komplett
		653590	Cuve 5 litres complète	Complete 5-litre bowl	Kessel 5 Liter komplett
		653593	Cuve 7 litres complète	Complete 7-litre bowl	Kessel 7 Liter komplett
S12		0D7983	Couvercle 4,5/5 litres complet	Complete 4.5/5-litre lid	Deckel 4,5/5 Liter komplett
		0D7984	Couvercle 7 litres complet	Complete 7-litre lid	Deckel 7 Liter komplett
S13		0D7947	Poignée bride couvercle éq.	Lid clamp handle assembly	Griff Stift Deckel komplett

N° N. Ref	Qtà Cad Kvant	Cod Código Kod	Designazione	Descripción	Beskrivning
32	1	voir S8	Maniglia raschietto	Asa de rasqueta	Handtag, skärare
34	1	voir S8	Raschietto vasca K45	Rasqueta de cuba K45	Skärare, skål K45
		voir S8	Raschietto vasca K55/K70	Rasqueta de cuba K55/K70	Skärare, skål K55/K70
35	1	0D5439	Impugnatura flangia coperchio	Asa brida de tapa	Handtagsfäste, lock
39	2	0D5442	Coprivite 6p con incavo (set x 10)	Cubretornillos 6p huecos (juego x 10)	Skydd, skruv med ihåligt huvud 6st. (sats x 10)
40	2	0D2108	Vite TCHC M5x12 (set x15)	Tornillo TCHC M5x10 (juego x15)	Skruv TCHC M5x10 (sats x 15)
41	1	voir S11	Vasca	Cuba	Skål
42	1	653579	Rotore liscio 4,5 litri	Rotor liso 4,5 litros	Slät rotor 4,5 liter
	1	653580	Rotore microdentato 4,5 litri	Rotor microdentadas 4,5 litros	Mikrotandad rotor 4,5 liter
	1	653581	Rotore liscio 5 litri	Rotor liso 5 litros	Slät rotor 5 liter
	1	653582	Rotore microdentato 5 litri	Rotor microdentadas 5 litros	Mikrotandad rotor 5 liter
	1	653583	Rotore liscio 7 litri	Rotor liso 7 litros	Slät rotor 7 liter
	1	653584	Rotore microdentato 7 litri	Rotor microdentadas 7 litros	Mikrotandad rotor 7 liter
43	1	0D5490	Guarnizione coperchio	Junta de tapa	Tätning, lock
44	1	0D5491	Coperchio 4,5/5,5 litri	Tapa 5 litros	Lock 5 liter
	1	0D5492	Coperchio 7 litri	Tapa 7 litros	Lock 7 liter
45	2	0D7973	Vite TF M3x10 (set x 10)	Tornillo TF M3x10 (juego x 10 )	Scrhaube TF M3x10 (sats x 10)
46	1	voir S13	Flangia	Brida	
47	1	0D1054	Tappo (jeu x 4)	Tapon (juego x 4 )	Lock (sats x 4)
S8		0D5493	Raschietto vasca coperchio completo K45	Rasqueta cuba tapa completa K45	Komplett skärare, skål, lock K45
		0D5494	Raschietto vasca coperchio completo K55/K70	Rasqueta cuba tapa completa K55/K70	Komplett skärare, skål, lock K55/K70
S10		0D5496	Impugnatura vasca in dotazione	Asa de cuba equipada	Utrustat skålhandtag
S11		653589	Vasca 4,5 litri completa	Cuba 4,5 litros completa	Komplett skål 4,5 liter
		653590	Vasca 5 litri completa	Cuba 5 litros completa	Komplett skål 5 liter
		653593	Vasca 7 litri completa	Cuba 7 litros completa	Komplett skål 7 liter
S12		0D7983	Coperchio 4,5/5 litri completo	Tapa 4,5/5 litros completa	Komplett lock 4,5/5 liter
		0D7984	Coperchio 7 litri completo	Tapa 7 litros completa	Komplett lock 7 liter
S13		0D7947	Impugnatura flangia completo	Asa brida de tapa omlpeta	Komplett Handtagsfäste, lock

**Vue éclatée Couvercle + Cuve / Lid + Bowl exploded view / Explosionszeichnung Kessel + Deckel / Esploso Coperchio + Vasca / Despiece Tapa + Cuba / Sprängskiss lock+skål**

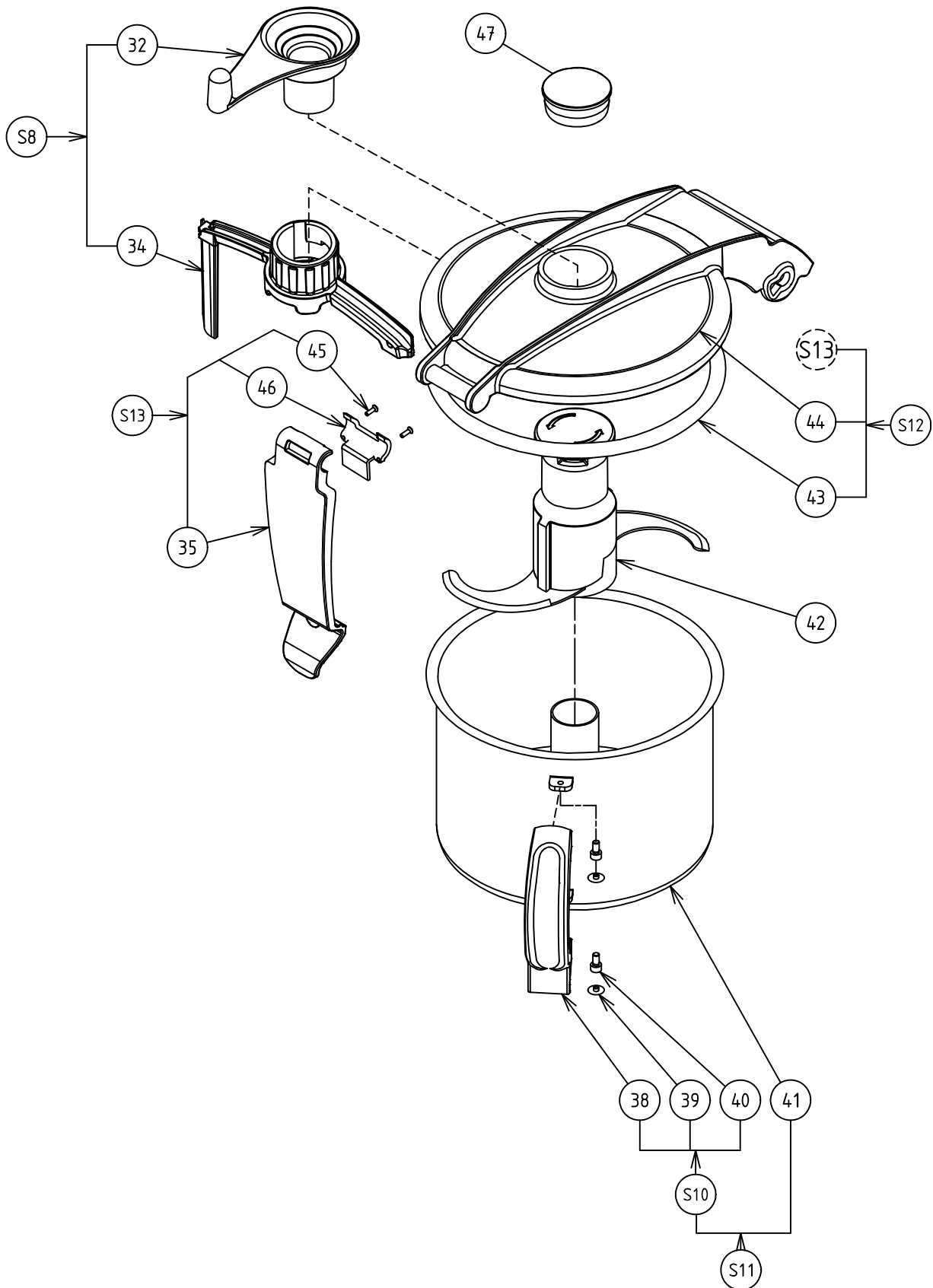

# Nomenclature commande platine vitesse monophasé / Parts list 1-speed single phase Control circuit board / Nomenclatura comando piastra 1 velocità monofase / Nomenclatura mando platina 1 velocidad monofásica / Spezifikation kontroll - platin 1 hastighet enfasig

Rep. Item Pos.	Qté Qty Mge	Code Part N° Teile-Nr	Désignation	Description	Bezeichnung
19	1	OD5429	Corps	Body	Gehäuseoberteil
48	1	OD7086	Plaque tableau de bord K45 1v	K45 1-sp control panel plate	Platte Bedienerfeld K45 1 GS
49	1	OD5515	Support carte commande	Control card support	Halterung Steuerkarte
50	1	OD7987	Carte commande P/M/A	Power/On/Off control card	Steuerkarte P/E/A
51	2	OD2918	Vis PTWN 1442 K30/8 (jeu x 10)	1442 K30/8 PTWN screw (set x 10)	Schraube PTWN 1442 K30/8 (jeu x 10)
53	2	OD5517	Support détecteur	Detector support	Sensorhalterung
54	3	OD6754	Vis M 4x12 (jeu x 10)	M 4x12 screw (set x 10)	Schraube M4x12 (10-er Satz)
55	2	OD6626	Détecteur proximité	Proximity detector	Näherungsschalter
56	2	OD0551	Vis taptite M6x12 (jeu x 10)	M6x12 Taptite screw (set x 10)	Taptite Schraube M6x12 (10-er Satz)
57	1	OD3590	Ecrou HU M8 cranté (jeu x 10)	HU M8 ring nut (set x 10)	Sechskantmutter M8 mit Verzahnung (10er-Satz)
58	1	OH1044	Condensateur permanent 20 mf	20 mf running capacitor	Dauerkondensator 20 mf
59	1	OD6438	Lyre	Spring clip	Federklammer
60	5	OD2848	Entretoise fixation c.i. (jeu x 6)	Printed circuit fixing spacer (set x 6)	Abstandshalter Befestigung Platine (6-er Satz)
61	1	OD5518	Support composant c.i.	Printed circuit component support	Halterung Bauteil Platine
62	1	OD7950	Carte de puissance mono	Single phase power card	Leistungskarte Wechselstrom
63	1	OKQ203	Condensateur démarrage 115 mf	115 mf start capacitor	Startkondensator 115 mf
64	1	OD7401	Resistance	Resistance	Widerstand
65	1	OD7436	Relais tension 230v	Starter relay 230v	Startrelais 230v
66	1	OD7951	Cordon d'alimentation mono équipé	Single phase power supply lead assembly	Stromkabel Wechselstrom ausgestattet
67	1	OD7969	Collier (jeu x 10)	Tie (set x 10)	Schelle CV8 (10-er Satz)
68	1	OD5135	Barrette (jeu x 5)	Terminal bar (set x 5)	Klemmenreihe (5-er Satz)
S14		OD5519	Carte commande complète K 45 1v	Complete K 45 1-sp control card	Steuerkarte komplett K 45 1 GS
S15		OD5542	Support PSA complet (porte clips)	Complete PSA support (clip holder)	Halterung PSA komplett (cliphalter)
S16		OD7978	Platine complète 1 v mono K45 750W	Complete 1 v single phase K45 750W circuit board	Platine komplett 1 GS Wechselstrom K45 750W

N° N. Ref	Qtà Cad Kvant	Cod Código Kod	Designazione	Descripción	Beskrivning
19	1	OD5429	Corpo	Cuerpo	Huvuddel
48	1	OD7086	Piastra pannello comandi K45 1v	Placa panel de mando K45 1v	Platta kontrollpanel K45 1v
49	1	OD5515	Supporto scheda di comando	Soporte tarjeta de mando	Stöd drivkort
50	1	OD7987	Scheda di comando P/M/A	Tarjeta mando P/M/A	Drivkort P/M/A
51	2	OD2918	Vite PTWN 1442 K30/8 (set x 10)	Tornillo PTWN 1442 K30/8 (juego x 10)	Skruv PTWN 1442 K30/8 (sats x 10)
53	2	OD5517	Supporto rilevatore	Soporte detector	Stöd detektor
54	3	OD6754	Vite M 4x12 (set x 10)	Tornillo M4x12 (juego x 10)	Skruv M 4x12 (sats x 10)
55	2	OD6626	Rilevatore di prossimità	Detector proximidad	Lägesdetektor
56	2	OD0551	Vite taptite M6x12 (set x 10)	Tornillo taptite M6x12 (juego x10)	Skruv M6x12 (sats x 10)
57	1	OD3590	Dado HU M8 dentato (set x 10)	Tuerca HU M8 microdentada (juego x 10)	Tandmutter HU M8 (sats x 10)
58	1	OH1044	Condensatore permanente 20 mf	Condensador permanente 20 mf	Permanent kondensator 20 mf
59	1	OD6438	Lira	Soporte lira	Lyra
60	5	OD2848	Distanziatore di fissaggio c.i. (set x 6)	Distanciador fijación c.i. (juego x 6)	Distansstycke montering t.k. (sats x 6)
61	1	OD5518	Supporto componente c.i.	Soporte componente c.i.	Stöd komponent t.k.
62	1	OD7950	Scheda di potenza mono	Tarjeta de potencia mono	Effektkort, mono
63	1	OKQ203	Condensatore di avviamento 115mf	Condensador arranque 115mf	Startkondensator 115mf
64	1	OD7401	Resistenza	Resistencia	Motstånd
65	3	OD7436	Relè Di Avvimento 230v	Relé De Arranque 230v	Startrelä 230v
66	1	OD7951	Cavo di alimentazione mono in dotazione	Cable de alimentación mono equipado	Utrustad elsladd, mono
67	1	OD7969	Fascetta (set x 10)	Abrazadera (juego x 10)	Klämna (sats x 10)
68	1	OD5135	Ponticello per morsetti ( set x 5)	Puente placa de bornes (juego x 5)	Uttagsplint (sats x 5)
S14		OD5519	Scheda di comando completa K 45 1v	Tarjeta mando completa K 45 1v	Komplett drivkort K 45 1v
S15		OD5542	Supporto PSA completo (portacclip)	Soporte PSA completo (portaclips)	Komplett stöd, PSA (clipshållare)
S16		OD7978	Piastra completa 1 v mono K45 750W	Platina completa 1 v mono K45 750W	Komplett platin, 1 v mono K45 750W

**Vue éclatée commande platine vitesse monophasé / 1-speed single phase control circuit board exploded view / Explosionszeichnung Steuerung Platine 1 Geschwindigkeit Wechselstrom / Esploso comando piastra 1 velocità monofase / Despiece mando platina 1 velocidad monofásica / Sprängskiss kontroll-platin 1 hastighet, enfasig**

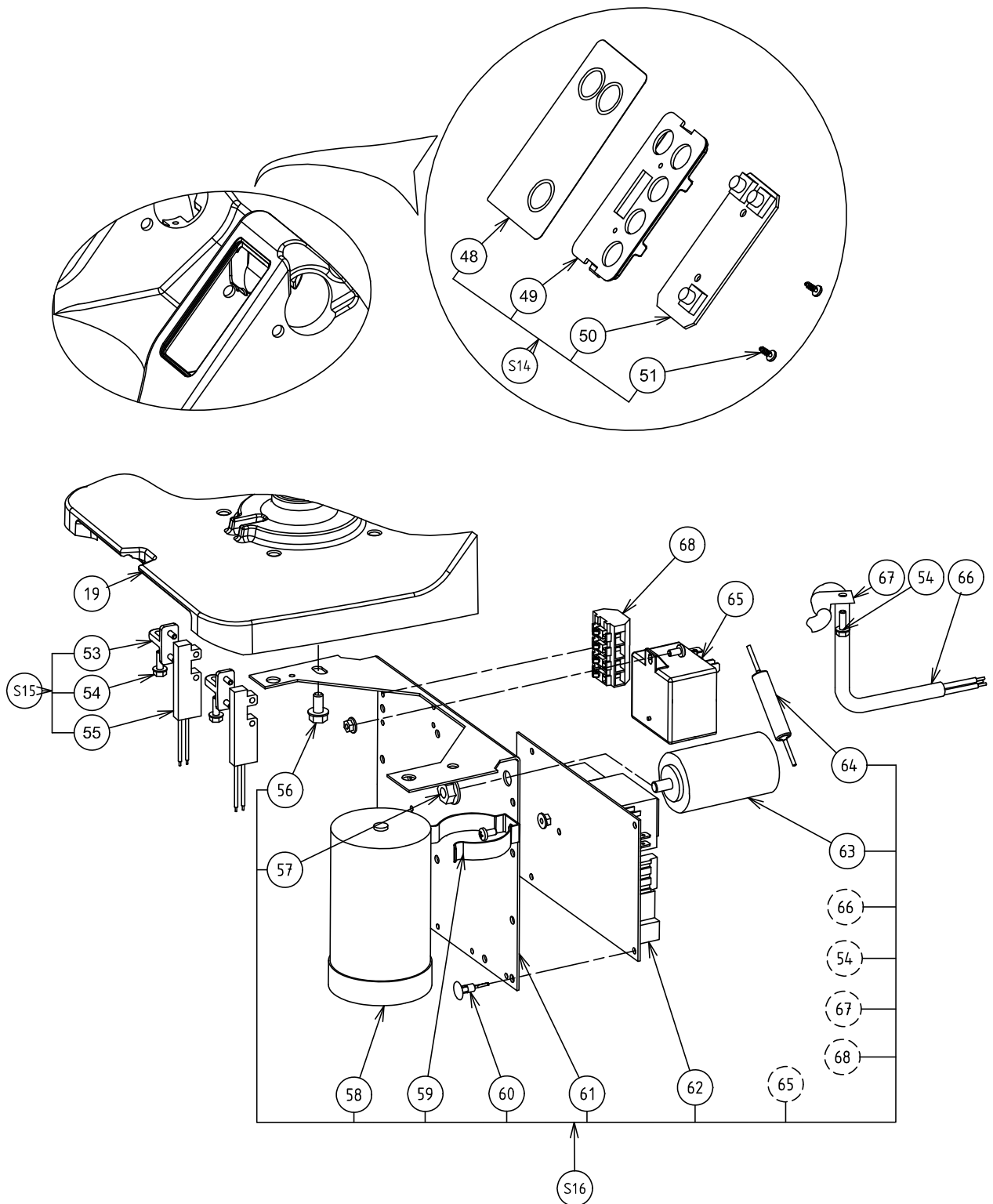



# Nomenclature platine 2 vitesses triphasé / Parts list 2-speed three-phase circuit board / Stückliste Platine 2 Geschwindigkeiten Drehstrom / Nomenclatura piastra 2 velocità trifase / Nomenclatura platina 2 velocidades trifásica / Specifikation platin 2 hastigheter, trefasig

Rep Item Pos.	Qté Qty Mge	Code Part N° Teile-Nr	Désignation	Description	Bezeichnung
19	1	0D5429	Corps	Body	Gehäuseoberteil
49	1	0D5515	Support carte commande	Control card support	Halterung Steuerkarte
51	2	0D2918	Vis PTWN 1442 K30/8 (jeu x 10)	1442 K30/8 PTWN screw (set x 10)	Schraube PTWN 1442 K30/8 (jeu x 10)
53	2	0D5517	Support détecteur	Detector support	Sensorhalterung
54	3	0D6754	Vis M4x12 (jeu x 10)	M4x12 screw (set x 10)	Schraube M4x12 (10-er Satz)
55	2	0D6626	Détecteur de proximité	Proximity detector	Näherungsschalter
79	1	0D7087	Plaque tableau de bord K45 2 V	K45 2-sp. control panel plate	Platte Bedienerfeld K45 2 GS
	1	0D7089	Plaque tableau de bord K55 2 V	K55 2-sp. control panel plate	Platte Bedienerfeld K55 2 GS
	1	0D7091	Plaque tableau de bord K70 2 V	K70 2-sp. control panel plate	Platte Bedienerfeld K70 2 GS
80	1	0D5600	Carte de commande 2 vitesses	2-speed control card	Steuerkarte 2 Geschwindigkeiten
81	1	0H1034	Condensateur de freinage 200 mf	200 mf brake capacitor	Bromskondensator 200 mf
83	1	0D6438	Lyre	Spring clip	Federklammer
84	2	0D6708	Vis taptite M6x16 (jeu x 10)	M6x16 Taptite screw (set x 10)	Taptite Schraube M6x16 (10-er Satz)
85	6	0D2848	Entretoise de fixation c.i. (jeu x 6)	Printed circuit fixing spacer (set x 6)	Abstandshalter Befestigung Platine (6-er Satz)
86	1	0D5518	Support composant de c.i.	Printed circuit component support	Halterung Bauteil Platine
87	1	0D7952	Carte de puissance 2 vitesses	2-speed power card	Leistungskarte 2 Geschwindigkeiten
88	1	0D7963	Cordon d'alimentation tri équipé	Three-phase power supply lead assembly	Stromkabel Drehstrom ausgestattet
89	1	0D7969	Collier (jeu x 10)	Tie (set x 10)	Schelle (10-er Satz)
100	2	0D6755	Vis TC M4x20 (jeux10)	Screw TC M4x20 (set x 10)	Schraube TC M4x20 (10-er Satz)
	2	0D6441	Entretoise 4x10x10 (jeux10)	Spacer (set x 10)	Abstandsring 4x10x10 (10-er Satz)
	2	0D6756	Ecrou M4 (jeux10)	Nut HU M4 base (set x 10)	Mutter M4 gezahnt (10-er Satz)
101	1	0D7953	Contact additif	Additive contact	Zusatzkontakt
102	2	0U0486	Contact additif	Additive contact	Zusatzkontakt
S22		0D6439	Support PSA complet 2V	Complete PSA support 2sp	Halterung PSA komplett 2GS
S17		0D5529	Carte commande complète K45 2V	Complete K45 2-sp. control card	Steuerkarte komplett K45 2GS
		0D5530	Carte commande complète K55 2V	Complete K55 2-sp. control card	Steuerkarte komplett K55 2GS
		0D5531	Carte commande complète K70 2V	Complete K70 2-sp. control card	Steuerkarte komplett K70 2GS
S18		0D7954	Platine complète 2v K45/K55/K70	Complete 2-sp. K45/K55/K70 circuit board	Platine komplett 2GS K45/K55/K70

N° N. Ref	Kvant	Cod Código Kod	Designazione	Descripción	Beskrivning
19	1	0D5429	Corpo	Cuerpo	Huvuddel
49	1	0D5515	Supporto scheda di comando	Soporte tarjeta de mando	Stöd drivkort
51	2	0D2918	Vite PTWN 1442 K30/8 (set x 10)	Tornillo PTWN 1442 K30/8 (juego x10)	Skruv PTWN 1442 K30/8 (sats x 10)
53	2	0D5517	Supporto rilevatore	Soporte detector	Stöd detektor
54	3	0D6754	Vite M4x12 (set x 10)	Tornillo M4x12 (juego x 10)	Skruv M4x12 (sats x 10)
55	2	0D6626	Rilevatore di prossimità	Detector de proximidad	Lägesdetektor
79	1	0D7087	Piastra pannello comandi K45 2 V	Placa panel de mando K45 2 V	Platta, kontrollpanel K45 2 V
	1	0D7089	Piastra pannello comandi K55 2 V	Placa panel de mando K55 2 V	Platta, kontrollpanel K55 2 V
	1	0D7091	Piastra pannello comandi K70 2 V	Placa panel de mando K70 2 V	Platta, kontrollpanel K70 2 V
80	1	0D5600	Scheda di comando 2 velocità	Tarjeta de mando 2 velocidades	Drivkort 2 hastigheter
81	1	0H1034	Condensatore di arresto 200 mf	Condensador de frenado 200 mf	Bromskondensator 200 mf
83	1	0D6438	Lira	Soporte lira	Lyra
84	2	0D6708	Vite taptite M6x16 (set x 10)	Tornillo taptite M6x16 (juego x10)	Skruv M6x16 (sats x 10)
85	6	0D2848	Distanziatore di fissaggio c.i. (set x 6)	Distanciador de fijación c.i. (juego x 6)	Distansstycke monterig t.k. (sats x 6)
86	1	0D5518	Supporto componente di c.i.	Soporte componente de c.i.	Stöd komponent i t.k.
87	1	0D7952	Scheda di potenza 2 velocità	Tarjeta de potencia 2 velocidades	Effektkort 2 hastigheter
88	1	0D7963	Cavo di alimentazione tri in dotazione	Cable de alimentación tri equipado	Utrustad elsladd, trefasig
89	1	0D7969	Fascetta (set x 10)	Abrazadera (juego x 10)	Klämma (sats x 10)
100	2	0D6755	Vite TC M4x20 (gioco x 10)	Tornillo TC M4x20 (juego x10)	Skruv TC M4x20 (sats x 10)
	2	0D6441	Distanziatore 4x10x10 (set x 10)	Distanciador 4x10x10 (juego x 10)	Tvärstång 4x10x10 (sats x 10)
	2	0D6756	Dado HU M4 base dentata (jeu x 10)	Tuerca HU M4 dentada (juego x 10)	Mutter HU M4 med räfflad fläns (sats x 10)
101	1	0D7953	Contacto additivo	Contacto adicional	Zusatzkontakt
102	2	0U0486	Contacto additivo	Contacto adicional	Zusatzkontakt
S22		0D6439	Supporto PSA completo 2V	Soporte PSA completo 2V	Komplett stöd, PSA 2V
S17		0D5529	Scheda di comando completa K45 2V	Tarjeta mando completa K45 2V	Komplett drivkort K45 2V
		0D5530	Scheda di comando completa K55 2V	Tarjeta mando completa K55 2V	Komplett drivkort K55 2V
		0D5531	Scheda di comando completa K70 2V	Tarjeta mando completa K70 2V	Komplett drivkort K70 2V
S18		0D7954	Piastra completa 2v K45/K55/K70	Platina completa 2v K45/K55/K70	Komplett platin 2v K45/K55/K70

**Vue éclatée platine 2 vitesses triphasé / 2-speed three-phase circuit board exploded view / Explosionszeichnung Platine 2 Geschwindigkeiten Drehstrom / Esploso piastra 2 velocità trifase / Despiece platina 2 velocidades trifásica / Sprängskiss platin 2 hastigheter, trefasig \_\_\_\_\_**

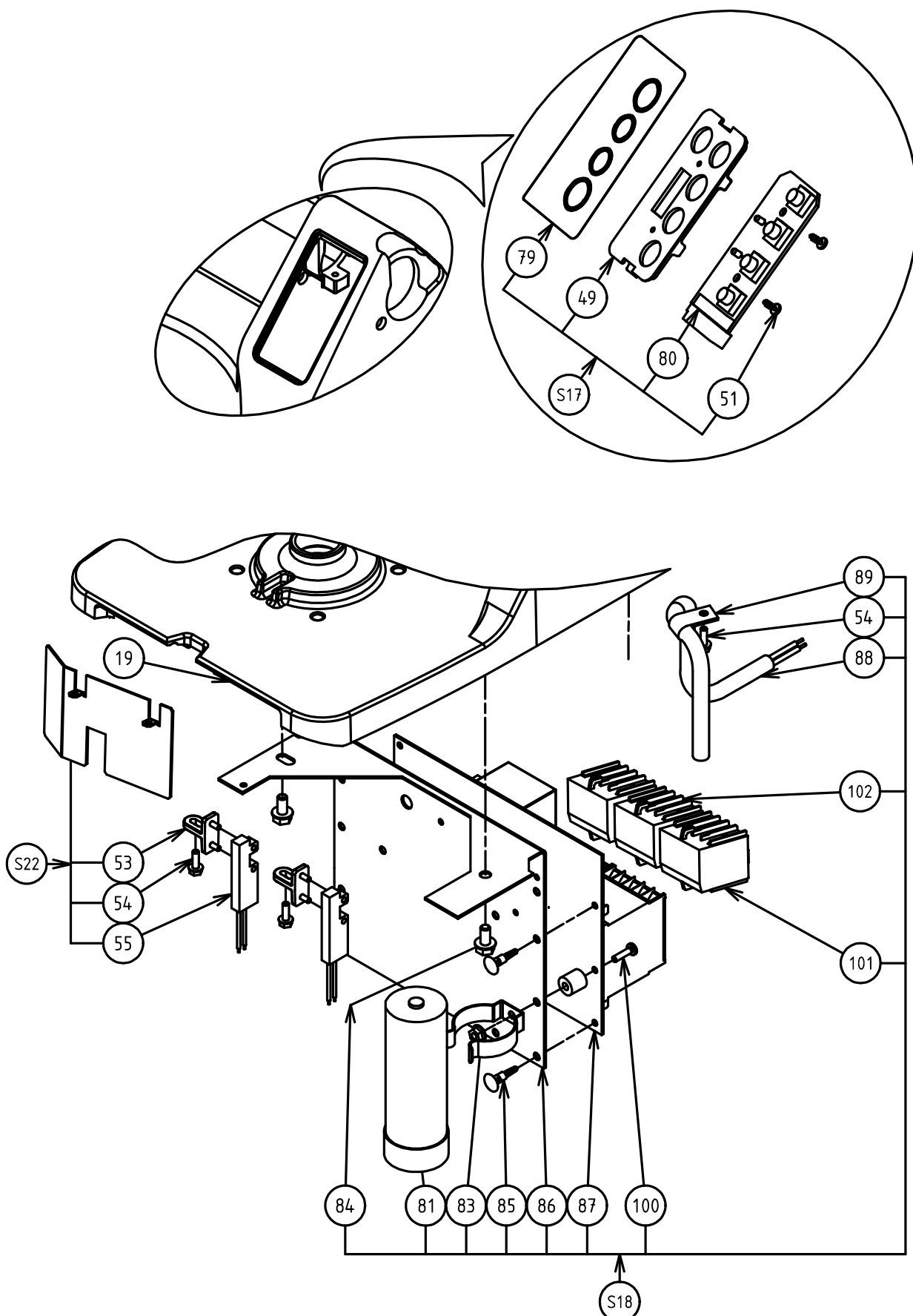

# Nomenclature platine variateur de vitesse / Parts list Variable speed unit circuit board / Stückliste Platine Regelantrieb / Nomenclatura piastra variatore di velocità / Nomenclatura platina variador de velocidad / Specification platin hastighetsvariator

Rep. Item Pos.	Qté Qty Mge	Code Part N° Teile-Nr	Désignation	Description	Bezeichnung
19	1	OD5429	Corps	Body	Gehäuseoberteil
49	1	OD5515	Support carte de commande	Control card support	Halterung Steuerkarte
51	2	OD2918	Vis PTWN 1442 K30/8 (jeu x 10)	1442 K30/8 PTWN screw (set x 10)	Schraube PTWN 1442 K30/8 (10-er Satz)
53	2	OD5517	Support détecteur	Detector support	Sensorhalterung
54	5	OD6754	Vis M4x12 (jeu x 10)	M4x12 screw (set x 10)	Schraube M4x12 (10-er Satz)
55	2	OD6626	Détecteur de proximité	Proximity detector	Näherungsschalter
90	1	OD7088	Plaque tableau de bord K45 V V	K45 Var. Sp. control panel plate	Platte Bedienerfeld K45 GR
	1	OD7090	Plaque tableau de bord K55 V V	K55 Var. Sp. control panel plate	Platte Bedienerfeld K55 GR
	1	OD7092	Plaque tableau de bord K70 V V	K70 Var. Sp. control panel plate	Platte Bedienerfeld K70 GR
91	1	OD5546	Carte de commande P/M/A/+/-	Power/On/off/+/- control card	Steuerkarte P/E/A/+/-
92	1	OD7976	Variateur	Variable speed unit	Regelantrieb
93	2	OD0551	Vis taptite M6x12 (jeu x 10)	M6x12 Taptite screw (set x 10)	Taptite Schraube M6x12 (10-er Satz)
94	1	voir S20	Support variateur	Variable speed unit support	Halterung Regelantrieb
95	1	OD6135	Cordon d'alimentation mono éq. CE	Single phase power supply lead ass. CE	Stromkabel Wechselstrom ausgestattet
	1	OD7979	Cordon UK	Single phase power supply lead ass. UK	Stromkabel Wechselstrom ausgestattet
	1	OD7980	Cordon Australie	Single phase power supply lead ass. AUS	Stromkabel Wechselstrom ausgestattet
96	1	OD7969	Collier (jeu x 10)	Tie (set x 10)	Schelle (10-er Satz)
97	1	OD7949	Ferrite	Ferrite	Ferrite
98	1	OD7948	Inductance	Inductance	Choke
99	2	OD5323	Vis M4x16 (jeu x 10)	M4x16 screw (set x 10)	Schraube M4x16 (10-er Satz)
S19	1	OD5749	Carte de commande K45 V V complète	Complete K45 Var. Sp. control card	Steuerkarte K45 GR komplett
	1	OD5750	Carte de commande K55 V V complète	Complete K55 Var. Sp. control card	Steuerkarte K55 GR komplett
	1	OD5751	Carte de commande K70 V V complète	Complete K70 Var. Sp. control card	Steuerkarte K70 GR komplett
S20	1	OD7949	Support variateur complet	Complete variable speed unit support	Halterung Regelantrieb komplett
S25	1	OD5543	Support PSA complet (porte-languettes)	Complete PSA support (lug holder)	Halterung PSA komplett (Laschenhalter)
S26	1	OD7982	Support PSA complet	Complete PSA support	Halterung PSA komplett

N° N. Ref	Qtà Cad Kvant	Cod Código Kod	Designazione	Descripción	Beskrivning
19	1	OD5429	Corpo	Cuerpo	Huvuddel
49	1	OD5515	Supporto scheda di comando	Soporte tarjeta de mando	Stöd drivkort
51	2	OD2918	Vite PTWN 1442 K30/8 (set x 10)	Tornillo PTWN 1442 K30/8 (juego x 10)	Skruv PTWN 1442 K30/8 (sats x 10)
53	2	OD5517	Supporto rilevatore	Soporte detector	Stöd detektor
54	5	OD6754	Vite M4x12 (set x 10)	Tornillo M4x12 (juego x 10)	Skruv M4x12 (sats x 10)
55	2	OD6626	Rilevatore di prossimità	Detector de proximidad	Lägesdetektor
90	1	OD7088	Piastra pannello comandi K45 V V	Placa panel de mando K45 V V	Platta kontrollpanel K45 V V
	1	OD7090	Piastra pannello comandi K55 V V	Placa panel de mando K55 V V	Platta kontrollpanel K55 V V
	1	OD7092	Piastra pannello comandi K70 V V	Placa panel de mando K70 V V	Platta kontrollpanel K70 V V
91	1	OD5546	Scheda di comando P/M/A/+/-	Tarjeta de mando P/M/A/+/-	Drivkort P/M/A/+/-
92	1	OD7976	Variatore	Variador	Variator
93	2	OD0551	Vite taptite M6x12 (set x 10)	Tornillo taptite M6x12 (juego x10)	Skruv M6x12 (sats x 10)
94	1	voir S20	Supporto variatore	Soporte variador	Stöd variatr
95	1	OD6135	Cavo di alim. mono in dotazione CE	Cable de alimentación mono eq. CE	Utrustad elsladd, mono CE
	1	OD7979	Cavo di alim. mono in dotazione UK	Cable de alimentación mono eq. UK	Utrustad elsladd, mono UK
	1	OD7980	Cavo di alim. mono in dotazione AUS	Cable de alimentación mono eq. AUS	Utrustad elsladd, mono AUS
96	1	OD7969	Fascetta (set x 10)	Abrazadera (juego x 10)	Klämma (sats x 10)
97	1	OD7949	Ferrite	Ferrite	Ferrite
98	1	OD7948	Inductance	Inductance	Inductance
99	2	OD5323	Vite M4x16 (set x 10)	Tornillo M4x16 (juego x 10)	Skruv M4x16 (sats x 10)
S19	1	OD5749	Scheda di comando K45 V V completa	Tarjeta de mando K45 V V completa	Komplett drivkort K45 V V
	1	OD5750	Scheda di comando K55 V V completa	Tarjeta de mando K55 V V completa	Komplett drivkort K55 V V
	1	OD5751	Scheda di comando K70 V V completa	Tarjeta de mando K70 V V completa	Komplett drivkort K70 V V
S20	1	OD5607	Supporto variatore completo	Soporte variador completo	Komplett stöd, variator
S25	1	OD5543	Supporto PSA completo (portalinguette)	Soporte PSA completo (portalingüetas)	Komplett stöd, PSA (flikhållare)
S26	1	OD7982	Supporto PSA completo	Soporte PSA completo	Komplett stöd, PSA

**Vue éclatée platine variateur de vitesse / Variable speed unit circuit board exploded view / Explosionszeichnung Platine Regelantrieb / Esploso piastra variatore di velocità / Despiece platina variador de velocidad / Sprängskiss platin hastighetsvariator**

