

# Spare parts List

Reservdelista



## Bricktransportör

Cord conveyor for trays

CE

DOC. NO. **ST0 3249-60**  
EDITION 1 2007.07



• Drivstation	4-7
• Centralstation	8-10
• El-skåp	11-12
• Kurva 45°	13
• Kurva 90°	14-15
• Rakdel	16
• Sorteringsdel	17
• Vändstation	18
• Sorteringstopp	19

• Drive unit	4-7
• Central drive unit	8-10
• Electrical cabinet	11-12
• Curve 45°	13
• Curve 90°	14-15
• Cord conveyor	16
• Cord conveyor sorting	17
• Return unit	18
• Sorting top	19

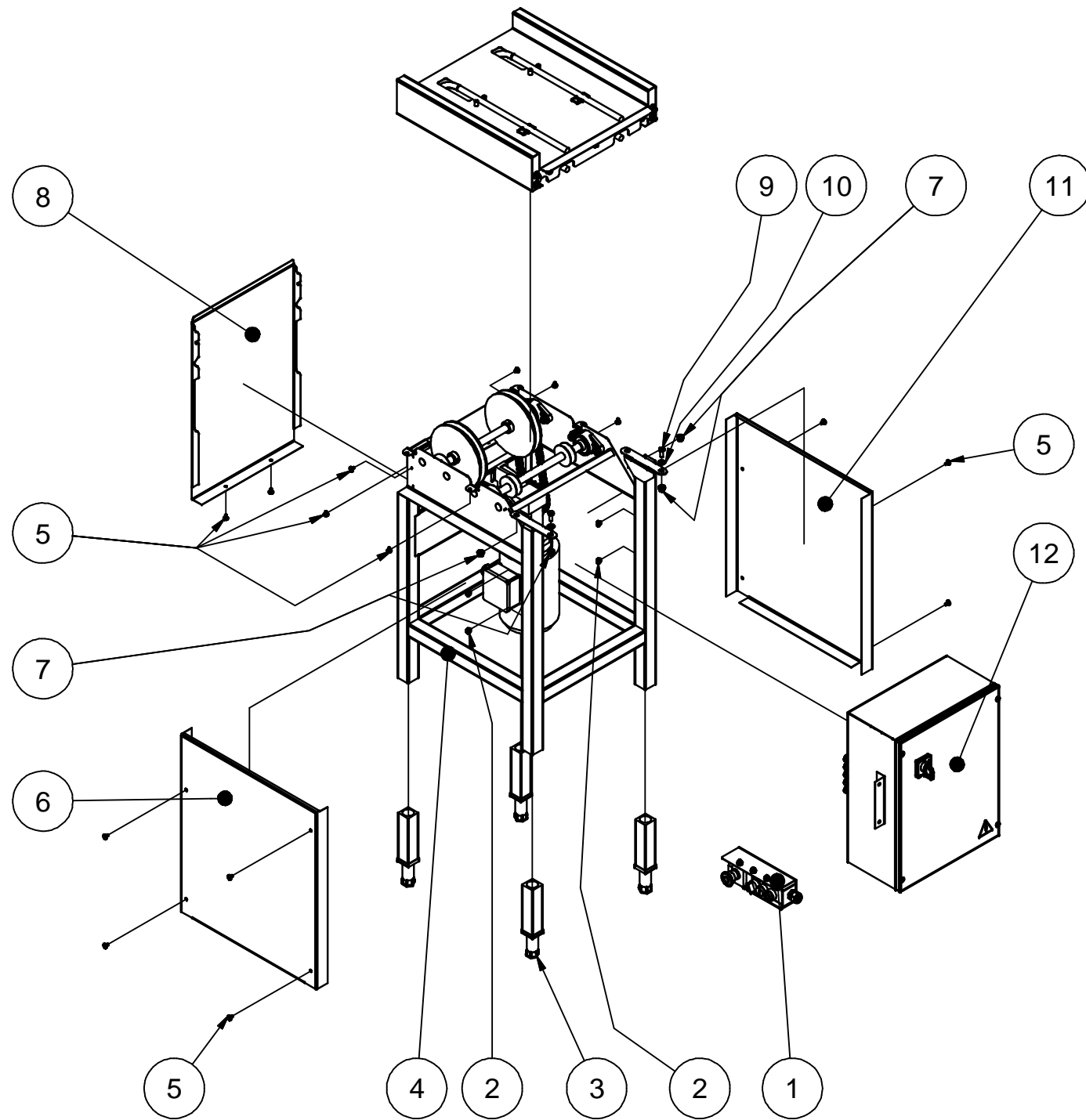

12	491 41 63-00	Electrical cabinet cpl.
11	ST0 46 47-01	Side cover RH
10	734 11 64-09	Washer 8,4x17x1,6
9	725 24 51-40	M6S 8x20
8	ST0 46 55-00	Front cover
7	552 21 21-04	Flange nut M8
6	ST0 46 47-00	Side cover LH
5	552 30 01-23	LSKS M5x10
4	ST0 46 39-00	Stand cpl.
3	ST0 33 76-00	Foot cpl.
2	552 21 21-03	Flange nut M6
1	491 42 74-00	Control box
Pos.	Art. No.	Description

Prod.no.  
9F865130-00

Drive unit

Edition 1

Date 2007-03

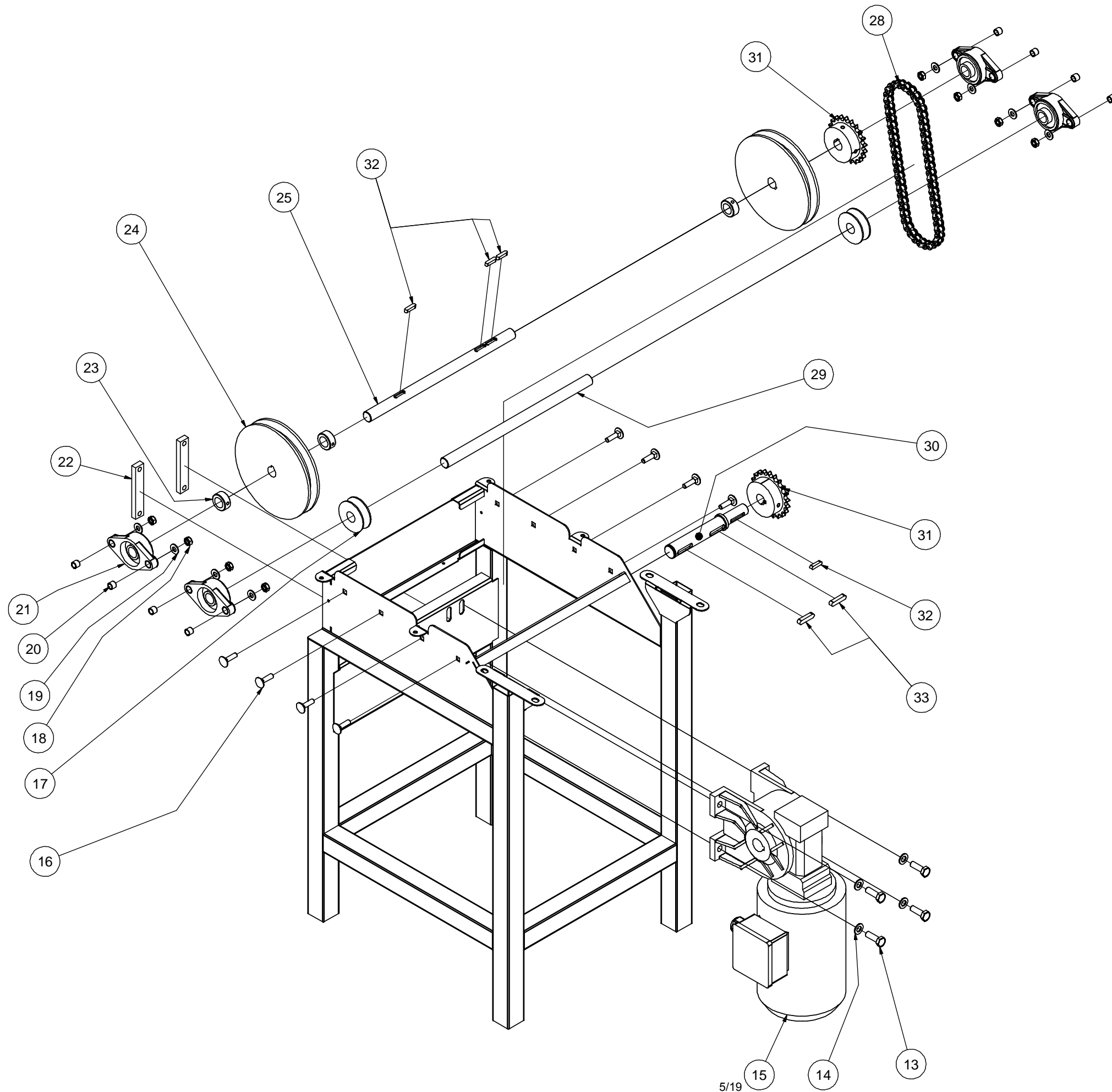

33	735 93 02-40	Key 8x7x36
32	735 9232-40	Key 6x6x25
31	491 35 50-00	Sprocker 1/2" Z=21
30	491 41 27-00	Motor shaft
29	ST0 46 76-00	Shaft
28	491 38 33-00	Chain
25	ST0 46 46-00	Shaft
24	ST0 47 05-00	Cord wheel
23	4823708-00	Retaining ring
22	491 41 67-00	Motor attachemnt
21	491 35 47-00	Flange bushing
20	ST0 35 91-00	Spacer pipe
19	734 11 64-09	Washer 8,4x17x1,6
18	731 23 18-40	M6M 8
17	ST0 44 81-00	Cord wheel
16	727 64 55-40	MVBF 8x30
15	520 69 40-00	Motor
14	734 11 73-09	BRB 10,5x20x1,8
13	725 24 95-40	M6S M10x30
Pos.	Art. No.	Description

Prod.no.  
9F865130-00

Drive unit

Edition 1

Date 2007-03

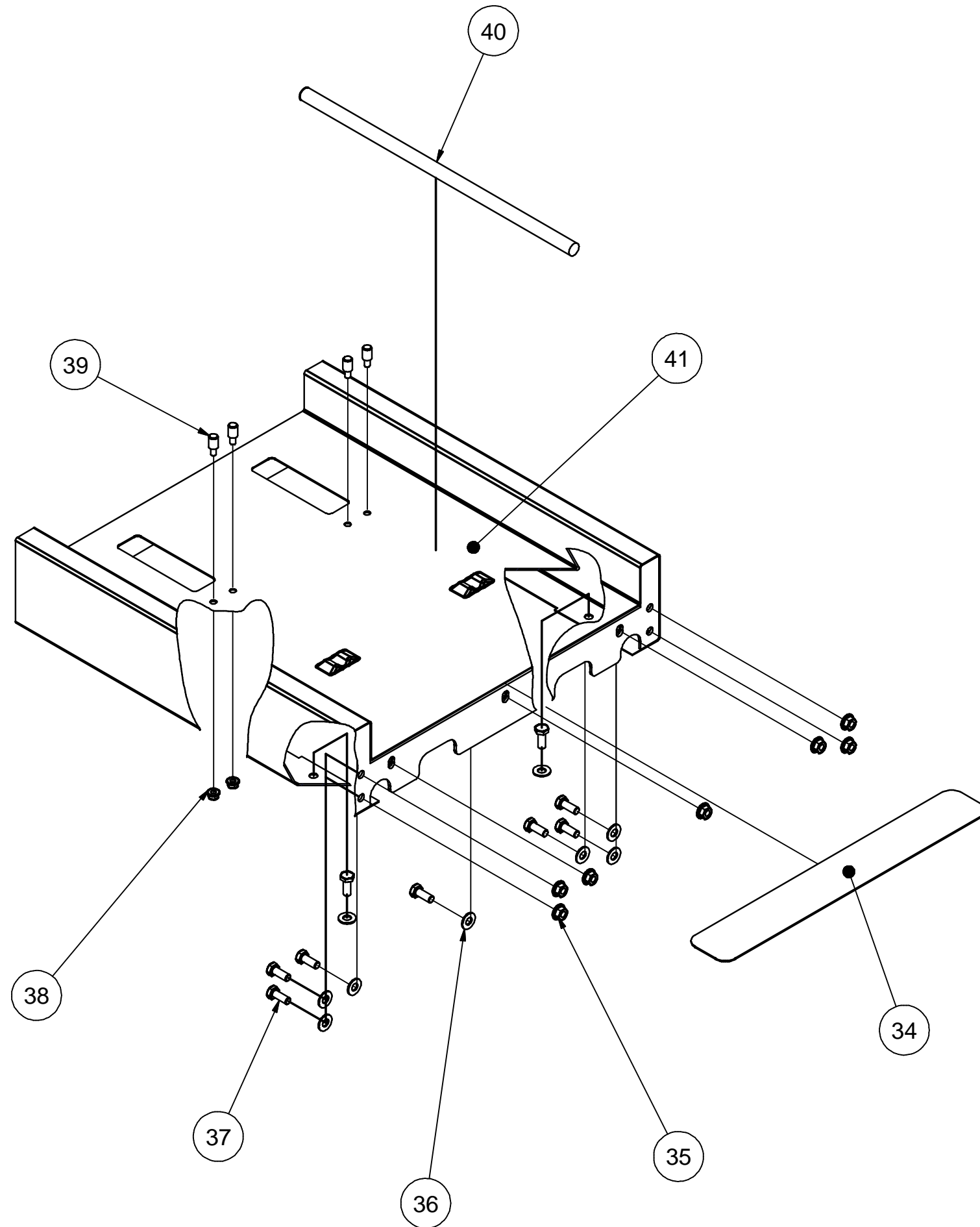

41	ST0 46 53-00	Track assy.
40	491 36 82-00	Cord
39	491 42 26-00	Safety pin
38	552 21 21-03	Flange nut M6
37	725 24 51-40	M6S 8x20
36	734 11 64-09	Washer 8,4x17x1,6
35	552 21 21-04	Flange nut M8
34	ST0 46 62-00	Support
Pos.	Art. No.	Description

Prod.no. 9F865130-00	Drive unit
Edition 1	Date 2007-03

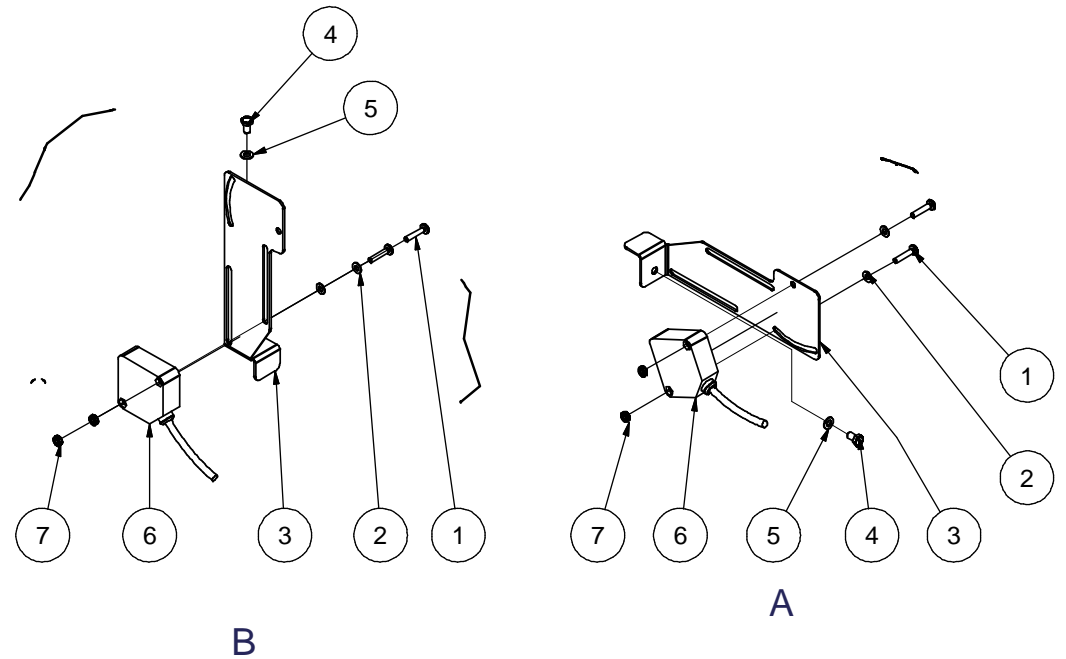
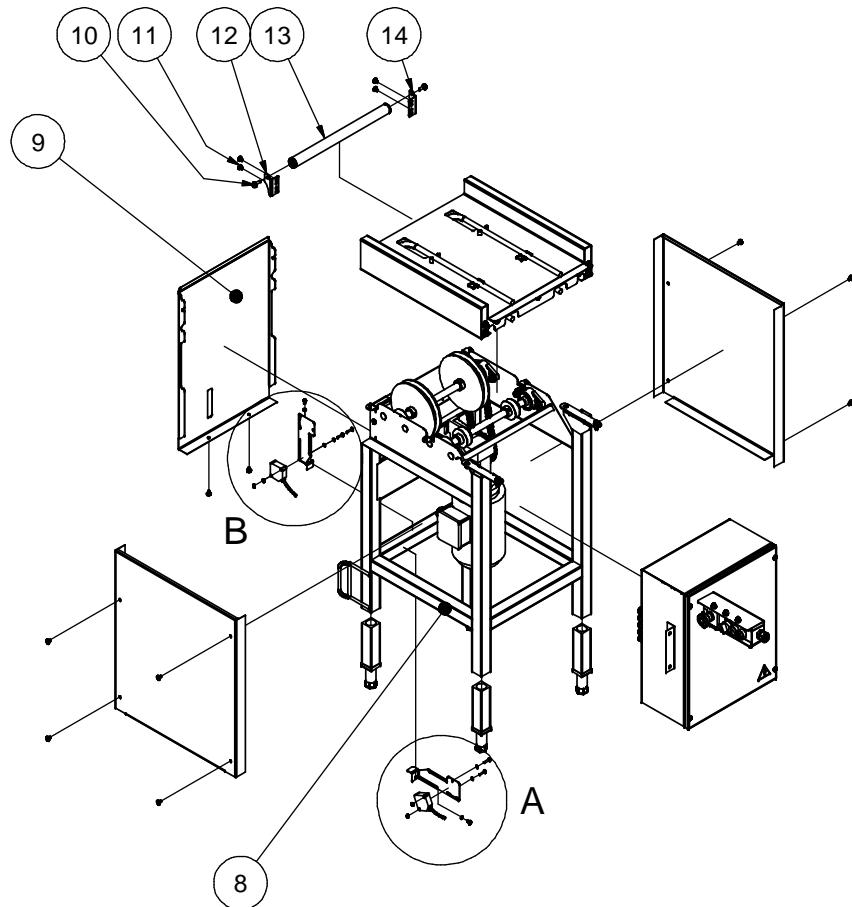

14	ST0 61 42-00	Bracket, Left
13	ST2 04 68-00	Pulley Ø30, M6, L=400
12	ST0 61 43-00	Bracket, Right
11	552 30 01-23	LSKS M5x10
10	552 30 03-00	M6SF 6x20 Rfr
9	ST0 61 41-00	Front cover
8	ST0 60 85-00	Stand cpl., tray unloading
7	731 23 12-40	M6M M4
6	ST0 61 44-00	Photoelectric sensor
5	734 11 46-09	Bricka 5,3x10
4	725 23 23-40	M6S M5x8 Rfr
3	ST0 61 45-00	Sensor bracket
2	734 11 36-09	BRB 4,3x9x0,8
1	724 12 95-40	MRX M4 x 20
Pos.	Art. No.	Description

Prod.no.  
9F865131-00 Drive unit with tray unloading

Edition 1

Date 2007-03

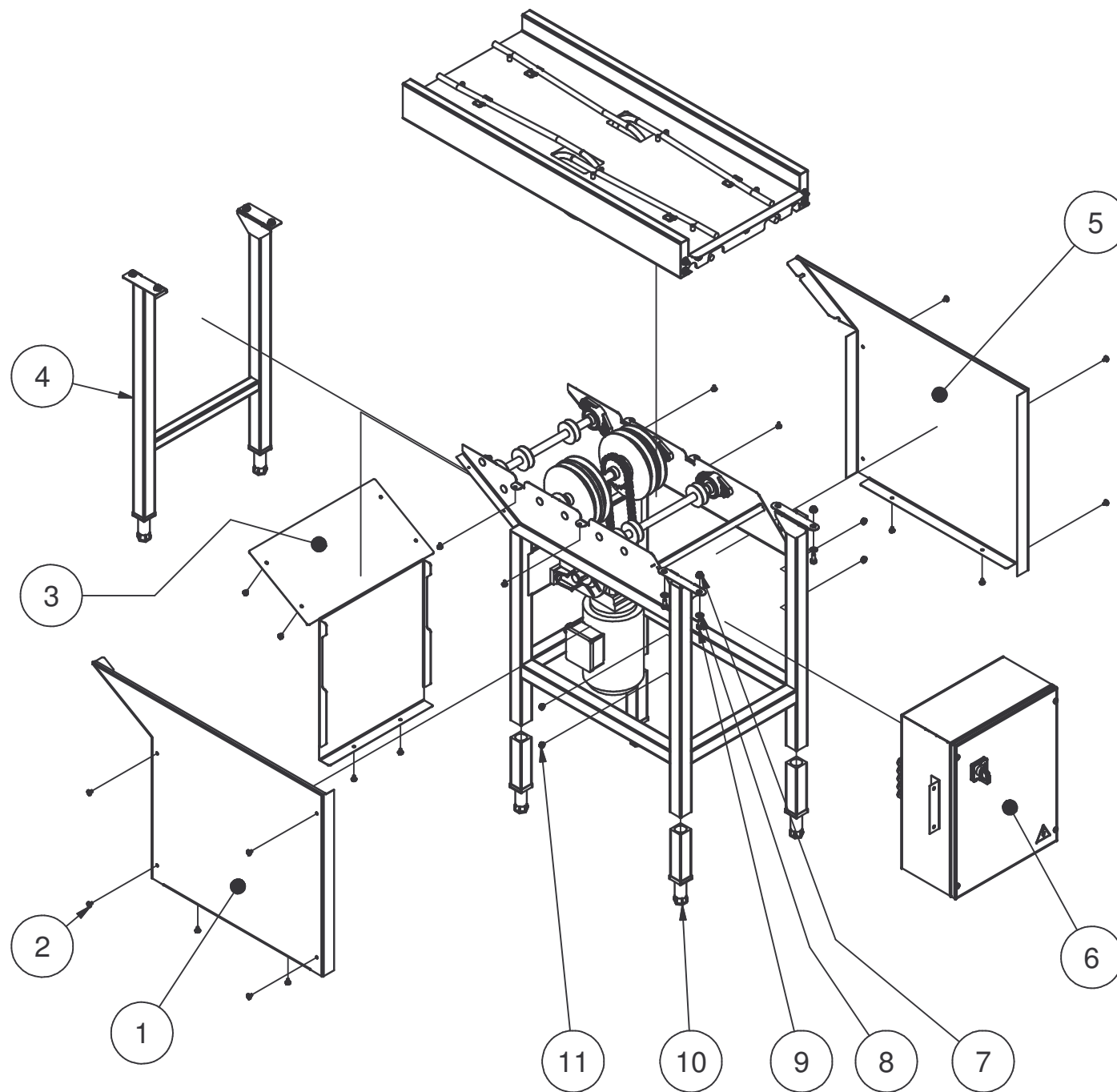

11	552 21 21-03	Flange nut M6 Rfr
10	ST0 33 76-00	Foot cpl.
9	725 24 49-40	M6S M8x16
8	734 11 64-09	Washer 8,4x17x1,6
7	552 21 21-04	Flange nut M8
6	491 41 63-00	Electrical cabinet cpl.
5	ST0 60 64-00	Side cover LH
4	ST0 61 40-00	Stand, tray slide
3	ST0 60 65-00	Front cover
2	552 30 01-23	LSKS M5x10
1	ST0 60 64-01	Side cover RH
Pos.	Art.No.	Description

Prod.no. 9F865132-00	Central drive unit
Edition 1	Date 2007-03

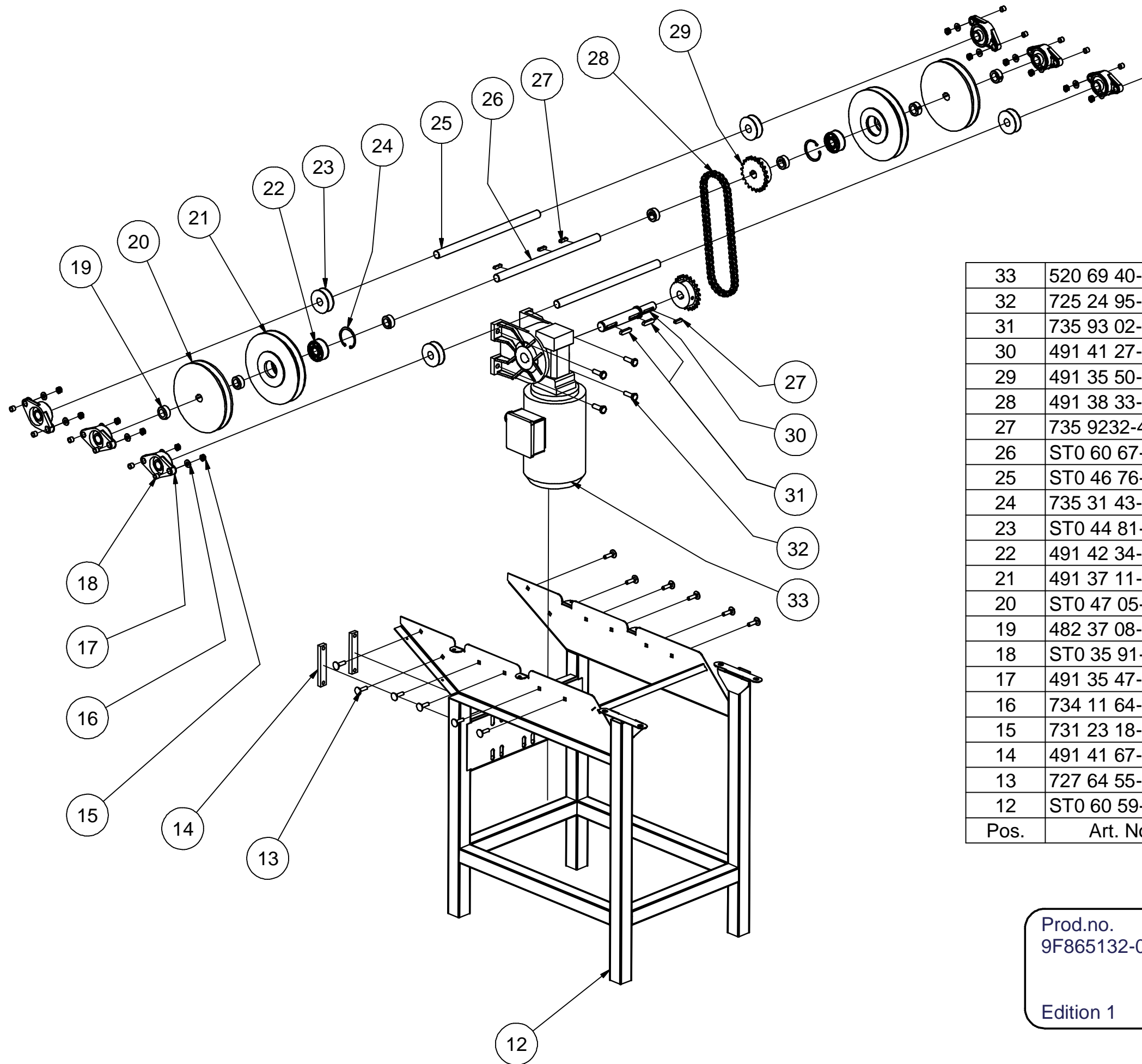

33	520 69 40-00	Motor
32	725 24 95-40	M6S M10x30
31	735 93 02-40	Wedge 8x7x36
30	491 41 27-00	Motor shaft
29	491 35 50-00	Sprocket 1/2" Z=21
28	491 38 33-00	Chain
27	735 9232-40	Wedge 6x6x25
26	ST0 60 67-00	Shaft
25	ST0 46 76-00	Shaft
24	735 31 43-19	Circlip SgH52
23	ST0 44 81-00	Cord wheel
22	491 42 34-00	Bushing
21	491 37 11-00	Cord wheel
20	ST0 47 05-00	Cord wheel
19	482 37 08-00	Retaining ring
18	ST0 35 91-00	Spacer pipe
17	491 35 47-00	Bushing
16	734 11 64-09	Washer 8,4x17x1,6
15	731 23 18-40	M6M 8
14	491 41 67-00	Motor attachemnt
13	727 64 55-40	MVBF 8x30
12	ST0 60 59-00	Stand cpl.
Pos.	Art. No.	Description

Prod.no.  
 9F865132-00      Central drive unit  
  
 Edition 1      Date 2007-03

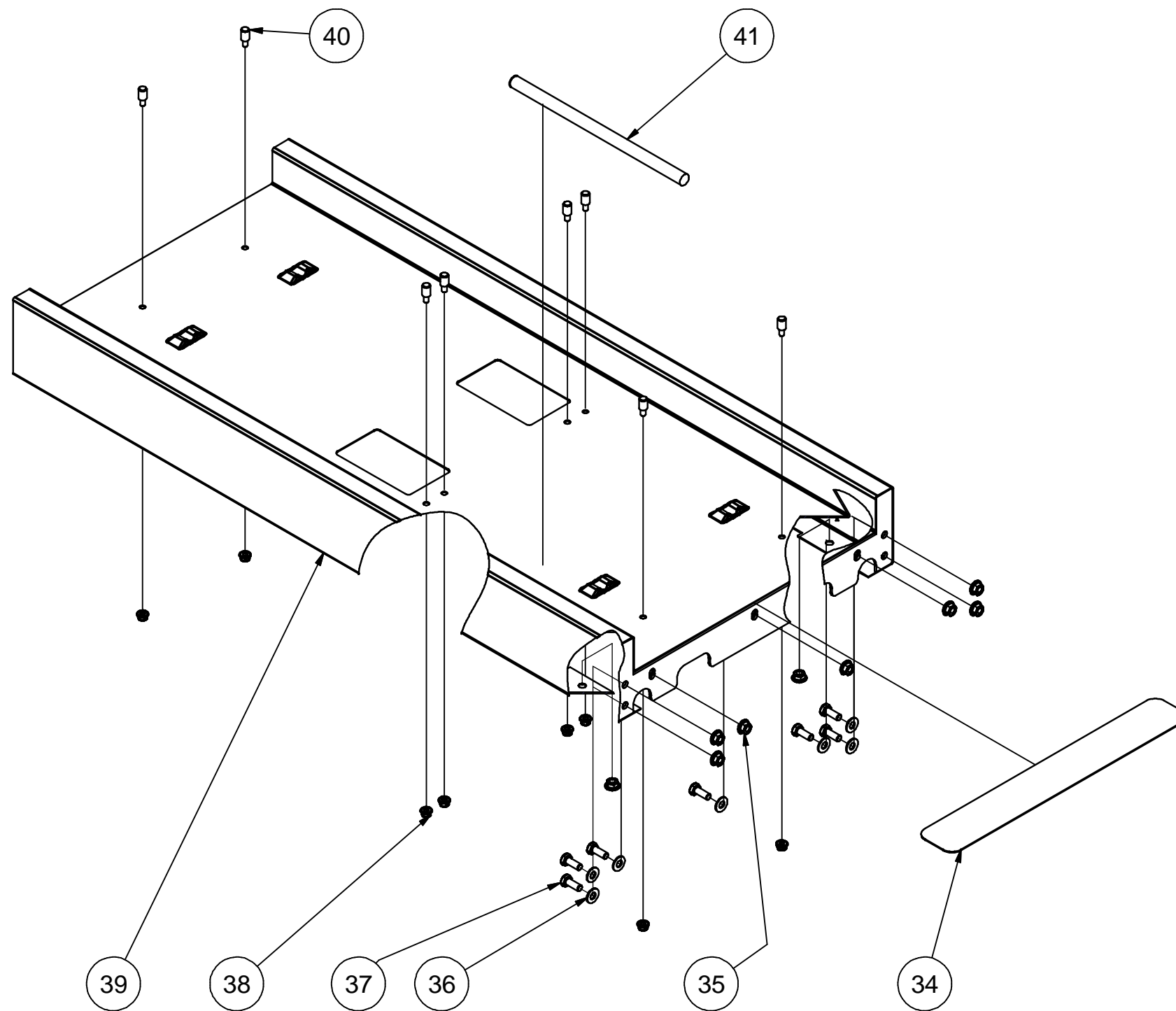

41	491 36 82-00	Cord
40	491 42 26-00	Safety pin
39	ST0 60 60-00	Track assy.
38	552 21 21-03	Flange nut M6
37	725 24 51-40	M6S 8x20
36	734 11 64-09	Washer 8,4x17x1,6
35	552 21 21-04	Flange nut M8
34	ST0 46 62-00	Support
Pos.	Art. No.	Description

Prod.no.  
9F865132-00      Central drive unit

Edition 1

Date 2007-03

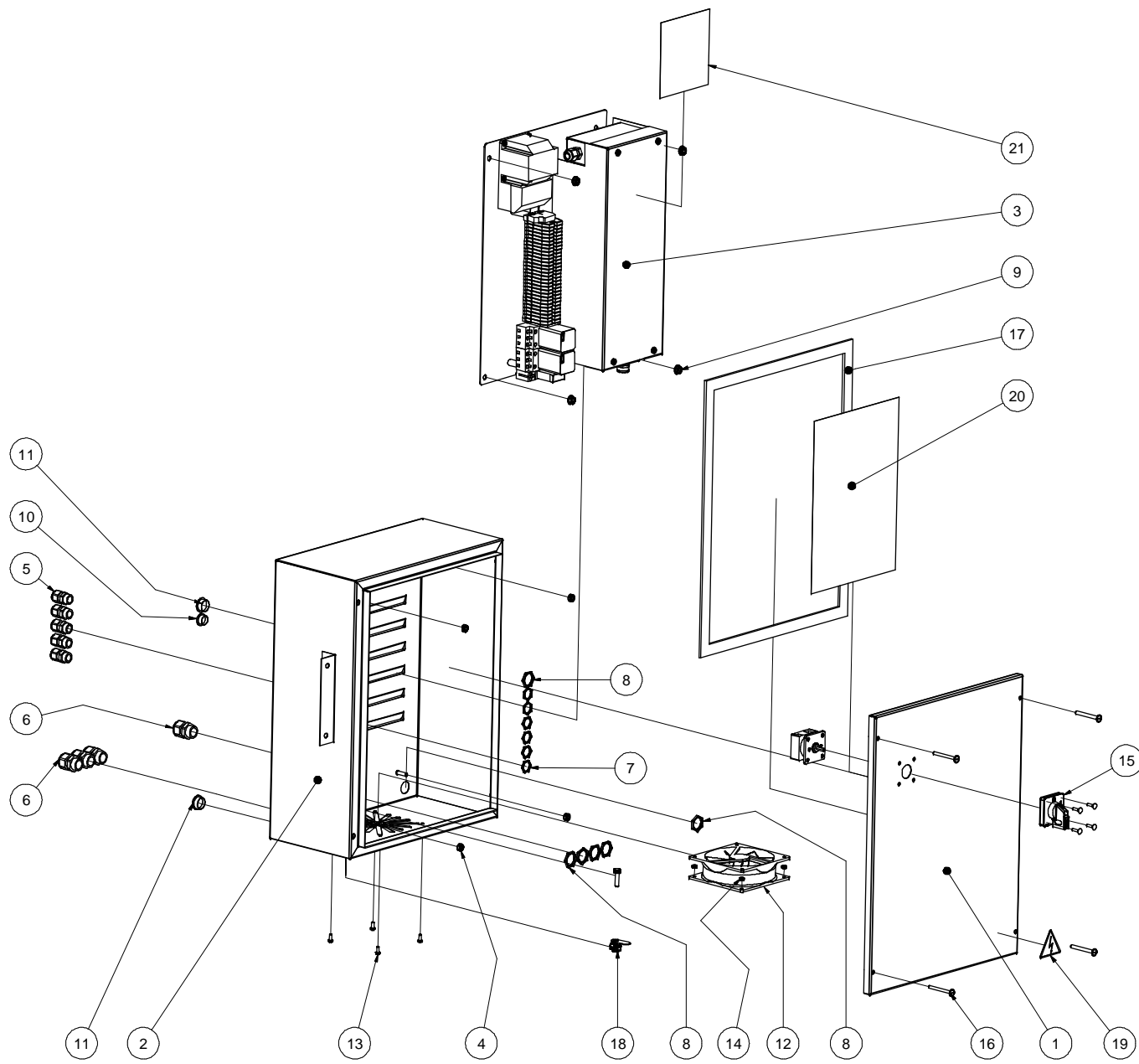

21	491 43 70-00	Sign, supply voltage
20	499 71 28-00	Electrical diagram
19	552 21 61-00	Warning plate
18	490 16 65-00	Ekvipotential screw
17	873 30 32-40	Sealing strip 20x4,2
16	552 30 01-31	LSKS M5x50
15	491 41 59-00	Safety switch
14	731 23 12-40	M6M M4
13	724 12 89-40	MRX 4x10
12	477 97 11-00	120 x 120 x 38 DC Fan
11	ST0 32 90-03	Blind plug M20x1.5
10	ST0 32 90-02	Blind plug M16x1.5
9	552 21 21-03	Flange nut M6 Rfr
8	ST0 28 64-03	Nut M20x1.5
7	ST0 28 64-02	Nut M16x1.5
6	ST0 31 45-10	Cable gland M20
5	ST0 31 45-09	Cable gland M16
4	731 23 16-40	M6M 6
3	491 41 37-00	Mounting plate kpl.
2	491 41 35-00	Electrical cabinet cpl.
1	491 39 67-00	Door, electrical cabinet
Pos.	Art.No.	Description

Prod.no.  
491 41 63-00      Electrical cabinet cpl.

Edition 1      Date 2007-03



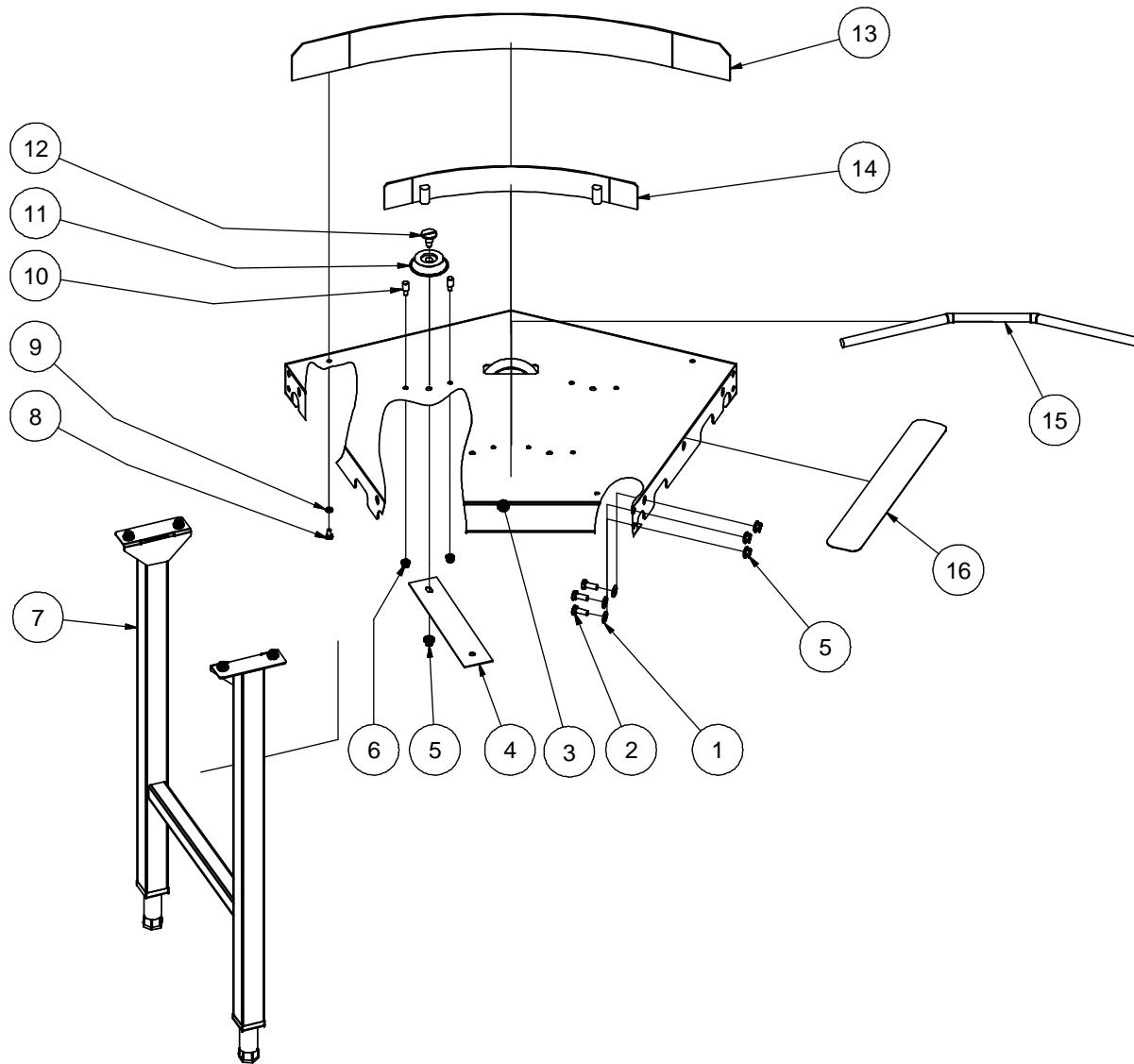

16	ST0 46 62-00	Support
15	491 36 82-00	Cord
14	491 35 58-00	Guide, inner
13	491 35 57-00	Guide, outer
12	ST0 48 76-00	Shouldred screw
11	ST0 48 75-00	Curve wheel
10	491 42 26-00	Safety pin
9	734 11 53-09	BRB 6,4x12x1,5
8	725 23 64-40	M6S 6x10
7	ST0 61 40-00	Stand, tray slide
6	552 21 21-03	Flange nut M6
5	552 21 21-04	Flange nut M8
4	491 39 77-00	Reinforcement
3	ST0 48 01-00	Track 45° curve cpl.
2	725 24 51-40	M6S 8x20
1	734 11 64-09	Washer 8,4x17x1,6
Pos.	Art. No.	Description

Prod.no.  
9F865129-00

Curve 45°

Edition 1

Date 2007-03

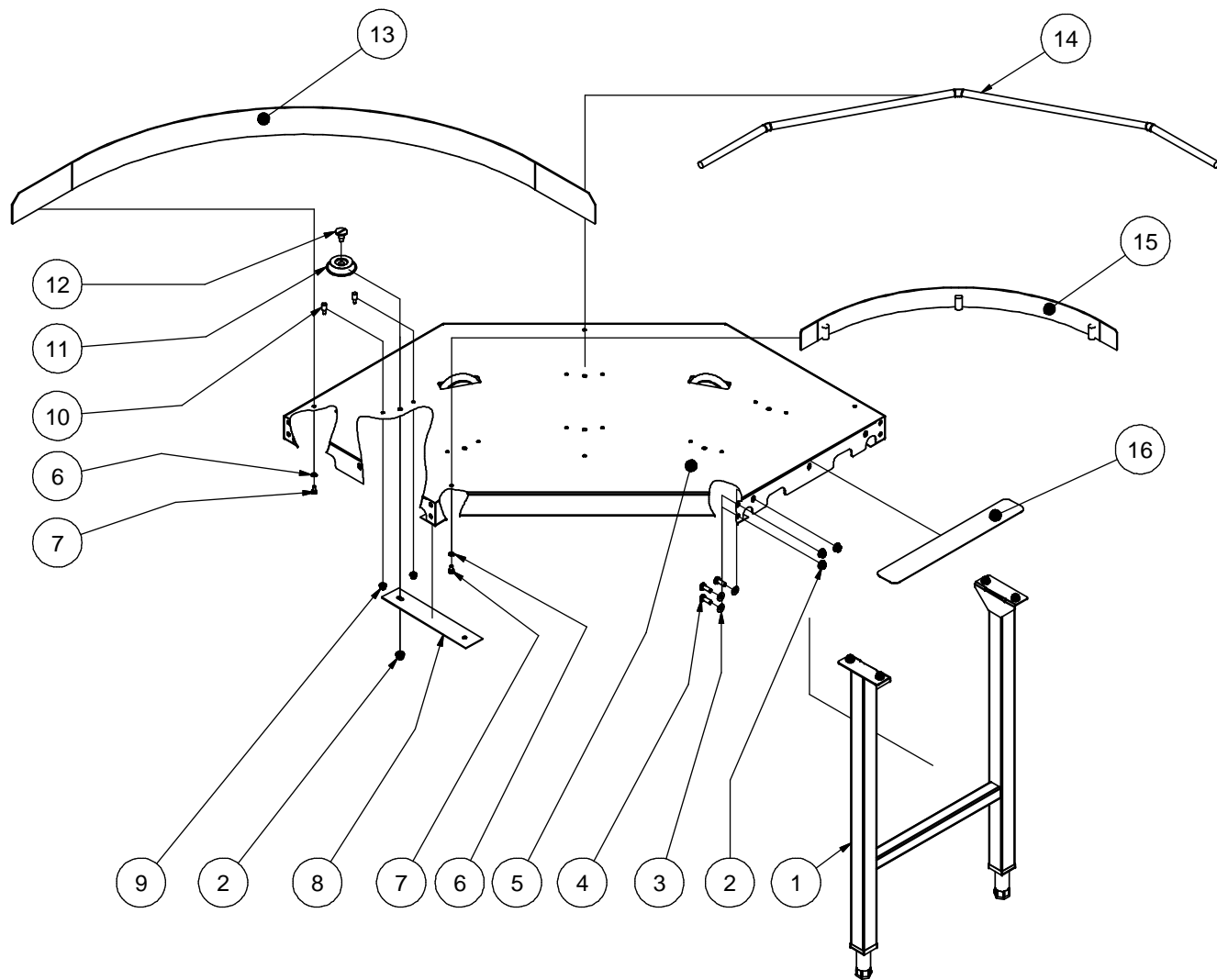

16	ST0 46 62-00	Support
15	491 39 73-00	Guide, inner
14	491 36 82-00	Cord
13	491 39 72-00	Guide, outer
12	ST0 48 76-00	Shouldred screw
11	ST0 48 75-00	Curve wheel
10	491 42 26-00	Safety pin
9	552 21 21-03	Flange nut M6
8	491 39 77-00	Reinforcement
7	725 23 64-40	M6S 6x10
6	734 11 53-09	Washer 6,4x12x1,5
5	ST0 47 32-00	Track 90° curve cpl.
4	725 24 51-40	M6S 8x20
3	734 11 64-09	Washer 8,4x17x1,6
2	552 21 21-04	Flange nut M8
1	ST0 61 40-00	Stand, tray slide
Pos.	Art. No.	Description

Prod.no.  
9F865128-00

Curve 90°

Edition 1

Date 2007-03

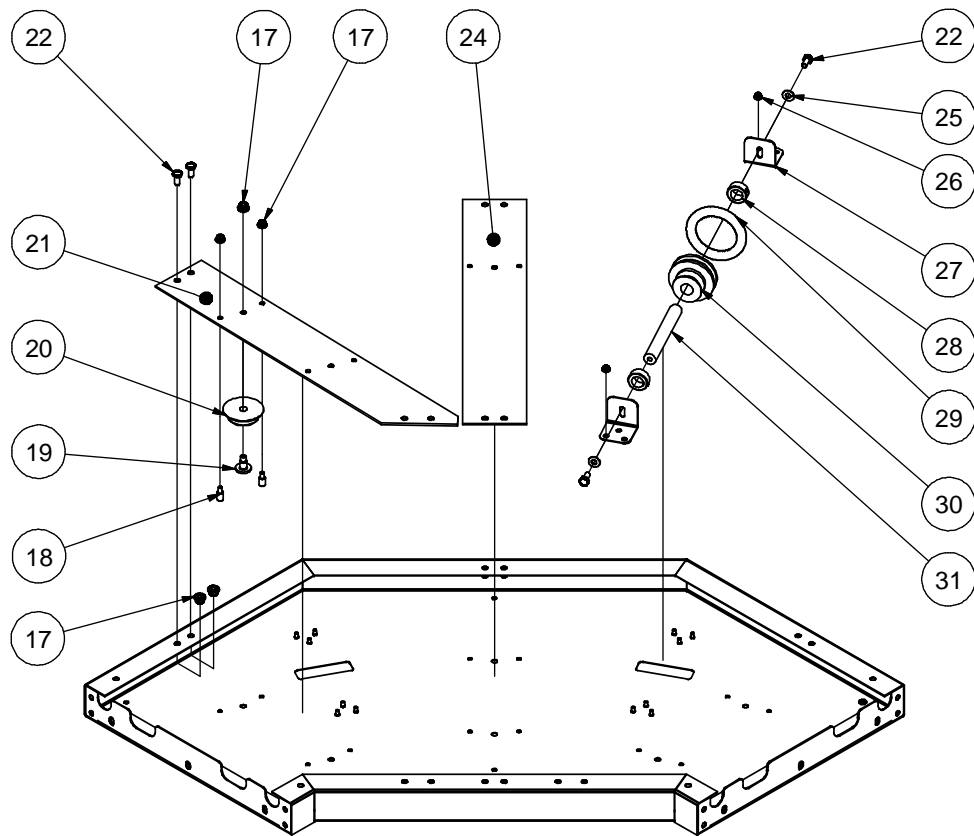

31	482 34 95-00	Shaft
30	491 38 95-00	Outer wheel
29	491 39 75-00	Cord ring
28	482 37 08-00	Retaining Ring
27	ST0 60 50-00	Shaft attachment
26	552 21 21-02	Flange nut M5
25	734 11 64-09	Washer 8,4x17x1,6
24	491 36 80-00	Tiebar, long
17	552 21 21-03	Flange nut M6
22	725 24 49-40	M6S M8x16
21	491 36 49-00	Tiebar, short
20	ST0 48 75-00	Curve wheel
19	ST0 48 76-00	Shouldred screw
18	491 42 26-00	Safety pin
17	552 21 21-04	Flange nut M8
Pos.	Art. No.	Description

Prod.no.  
9F865128-00

Curve 90°

Edition 1

Date 2007-03

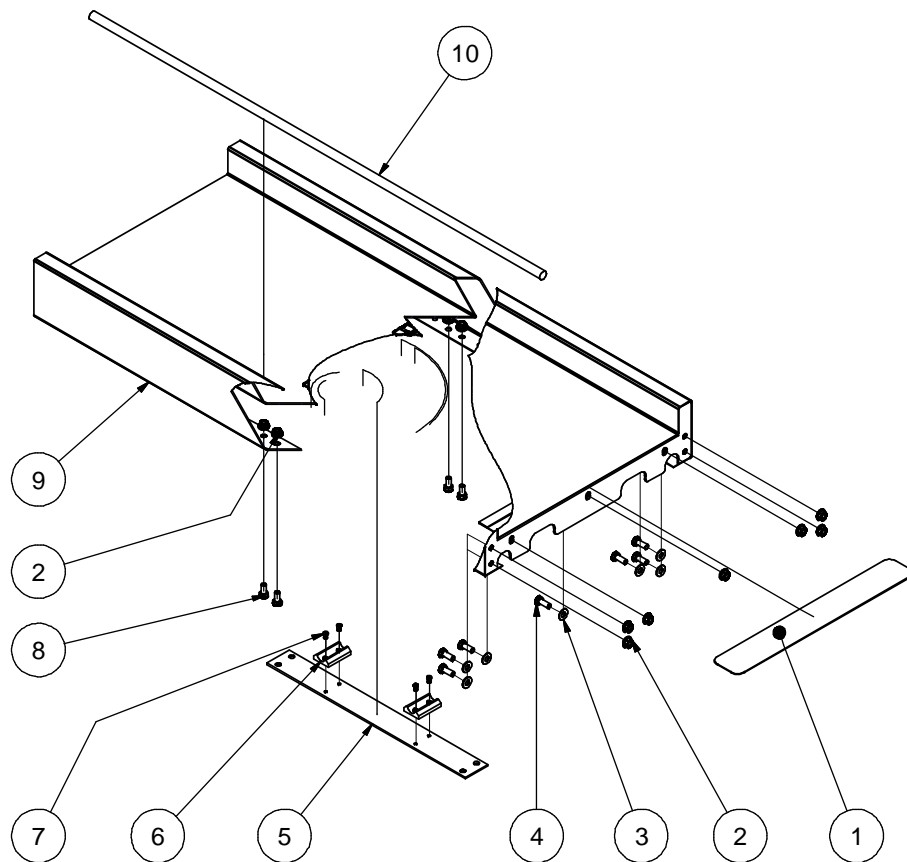

10	491 36 82-00	Cord
9	ST0 46 57-02	Track cpl. L=3000
9	ST0 46 57-01	Track cpl. L=2000
9	ST0 46 57-00	Track cpl. L=1000
8	725 24 49-40	M6S M8x16
7	552 21 02-01	Blind rivet 4x10
6	491 37 45-00	Cord guide
5	491 37 44-00	Tie bar
4	725 24 51-40	M6S 8x20
3	734 11 64-09	Washer 8,4x17x1,6
2	552 21 21-04	Flange nut M8
1	ST0 46 62-00	Support
Pos.	Art. No.	Description

Prod.no.	
9F865122-00	Cord conveyor tray L=1000
9F865123-00	Cord conveyor tray L=2000
9F865124-00	Cord conveyor tray L=3000

Edition 1

Date 2007-03

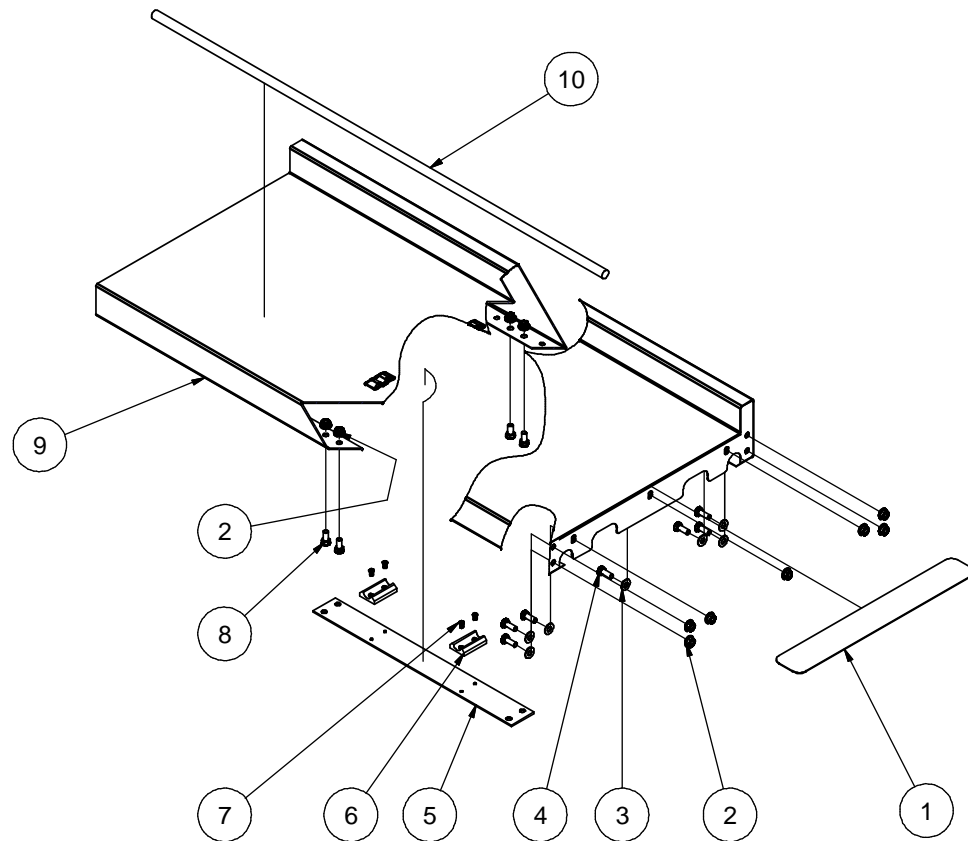

10	491 36 82-00	Cord
9	ST0 48 67-02	Sorting Track cpl. L=3000
9	ST0 48 67-01	Sorting Track cpl. L=2000
9	ST0 48 67-00	Sorting Track cpl. L=1000
8	725 24 49-40	M6S M8x16
7	552 21 02-01	Blind rivet 4x10
6	491 37 45-00	Cord guide
5	491 37 44-00	Tie bar
4	725 24 51-40	M6S 8x20
3	734 11 64-09	Washer 8,4x17x1,6
2	552 21 21-04	Flange nut M8
1	ST0 46 62-00	Support
Pos.	Art. No.	Description

Prod.no.	
9F865125-00	Cord conveyor tray, sorting L=1000
9F865126-00	Cord conveyor tray, sorting L=2000
9F865127-00	Cord conveyor tray, sorting L=3000

Edition 1

Date 2007-03

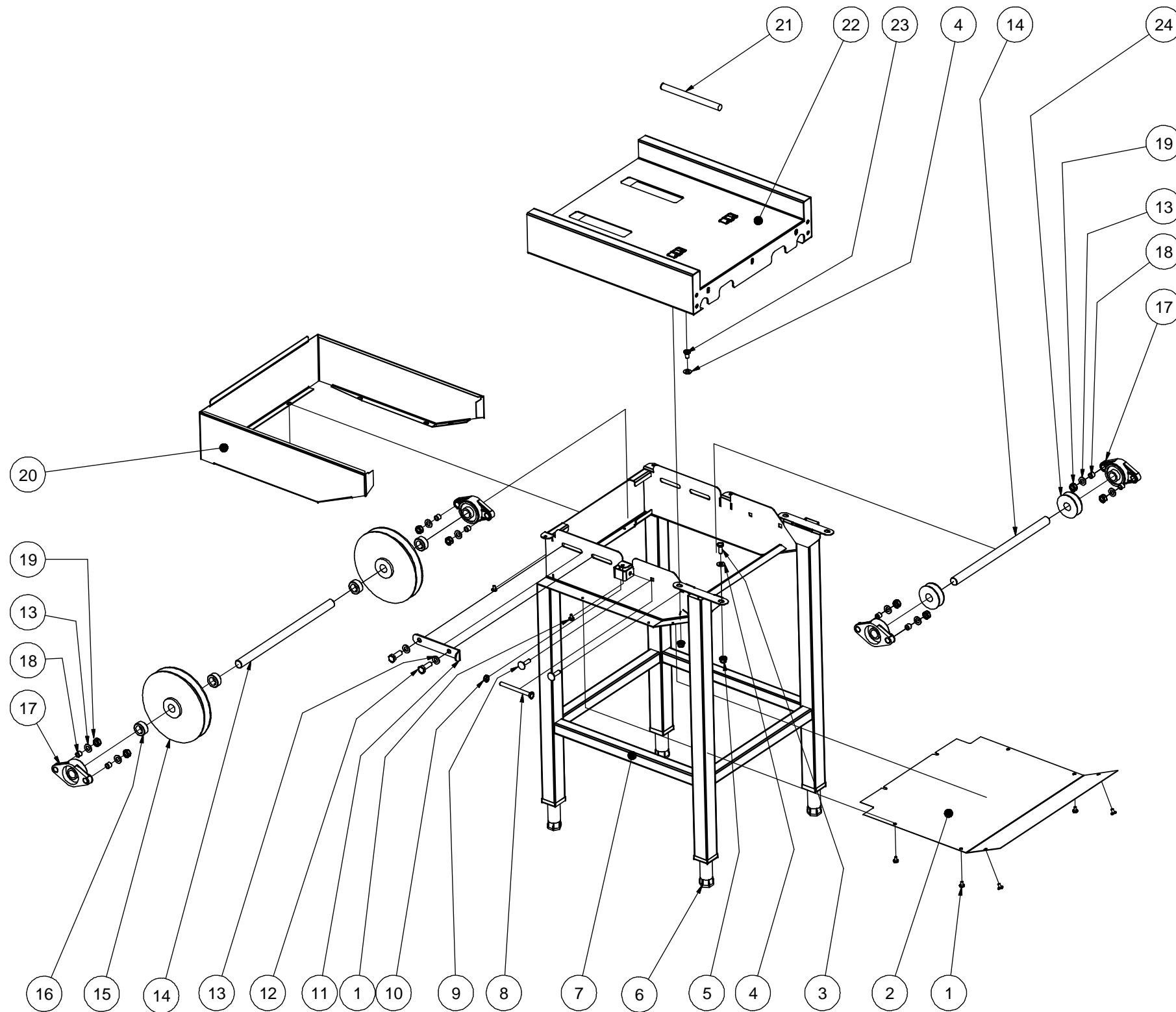

24	ST0 44 81-00	Cord wheel
23	725 24 47-40	M6S M8x12
22	ST0 46 77-00	Track
21	491 36 82-00	Cord
20	ST0 59 88-00	Cover, return unit
19	731 23 20-40	M6M 10 Rfr
18	ST0 35 91-00	Spacer pipe
17	491 35 47-00	Flänslager FYTBKC 20NTH
16	482 37 08-00	Stopping
15	ST0 45 62-00	Cord wheel
14	ST0 46 76-00	Shaft
13	734 11 73-09	BRB 10,5x20x1,8
12	725 24 95-40	M6S M10x30
11	ST0 59 89-00	Tension plate
10	7312318-40	M6M 8
9	727 64 55-40	MVBF 8x30 Rfr
8	725 24 69-45	M6S 8x90 Rfr
7	ST0 46 75-00	Stand cpl, return unit
6	ST0 33 76-00	Foot cpl.
5	552 21 21-04	Flänsmutter M8
4	734 11 64-09	Bricka 8,4x17x1,6
3	725 24 51-40	M6S 8x20
2	ST0 46 81-00	Cover
1	552 30 01-23	LSKS M5x10
Pos.	Art. No.	Description

Prod.no. 9F865133-00	Return unit
Edition 1	Date 2007-03

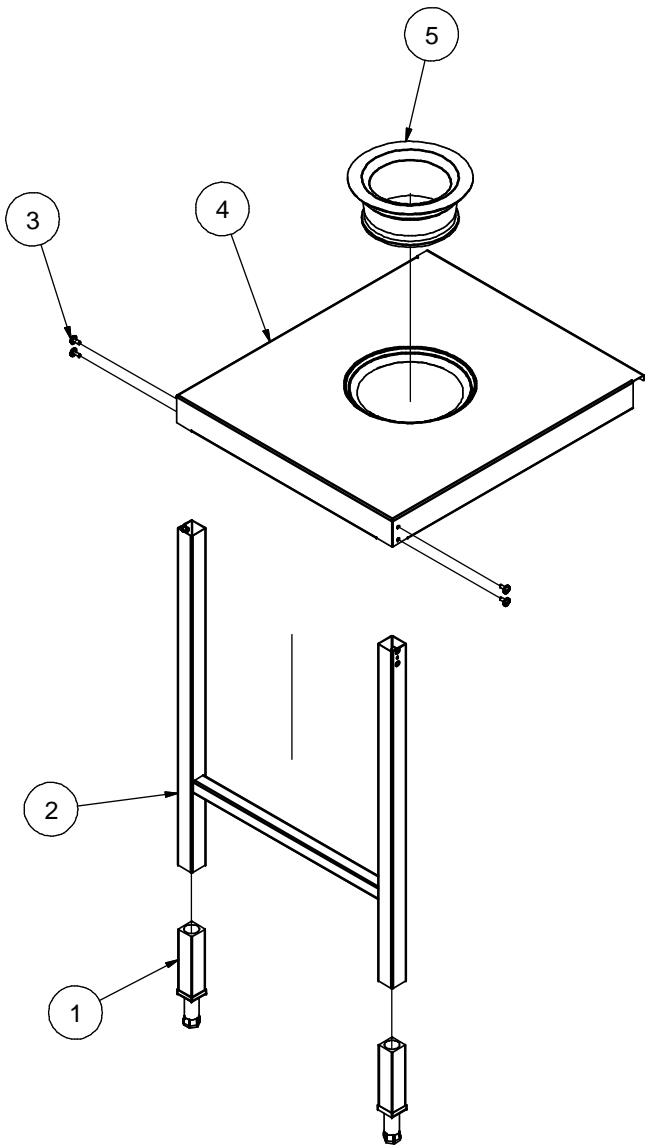

5	ST0 58 37-00	Rubber ring
4	ST0 66 87-00	Sorting top for rubber ring and legs
3	552 30 01-35	LSKS M6x16 Rfr
2	ST0 66 88-00	Stand cpl, Sorting top
1	ST0 33 76-00	Foot cpl.
Pos.	Art.No.	Description

Prod.no.  
9F865150-00      Sorting top,on legs, with hole and rubber ring

Edition 1      Date 2007-07