

# Spare part list

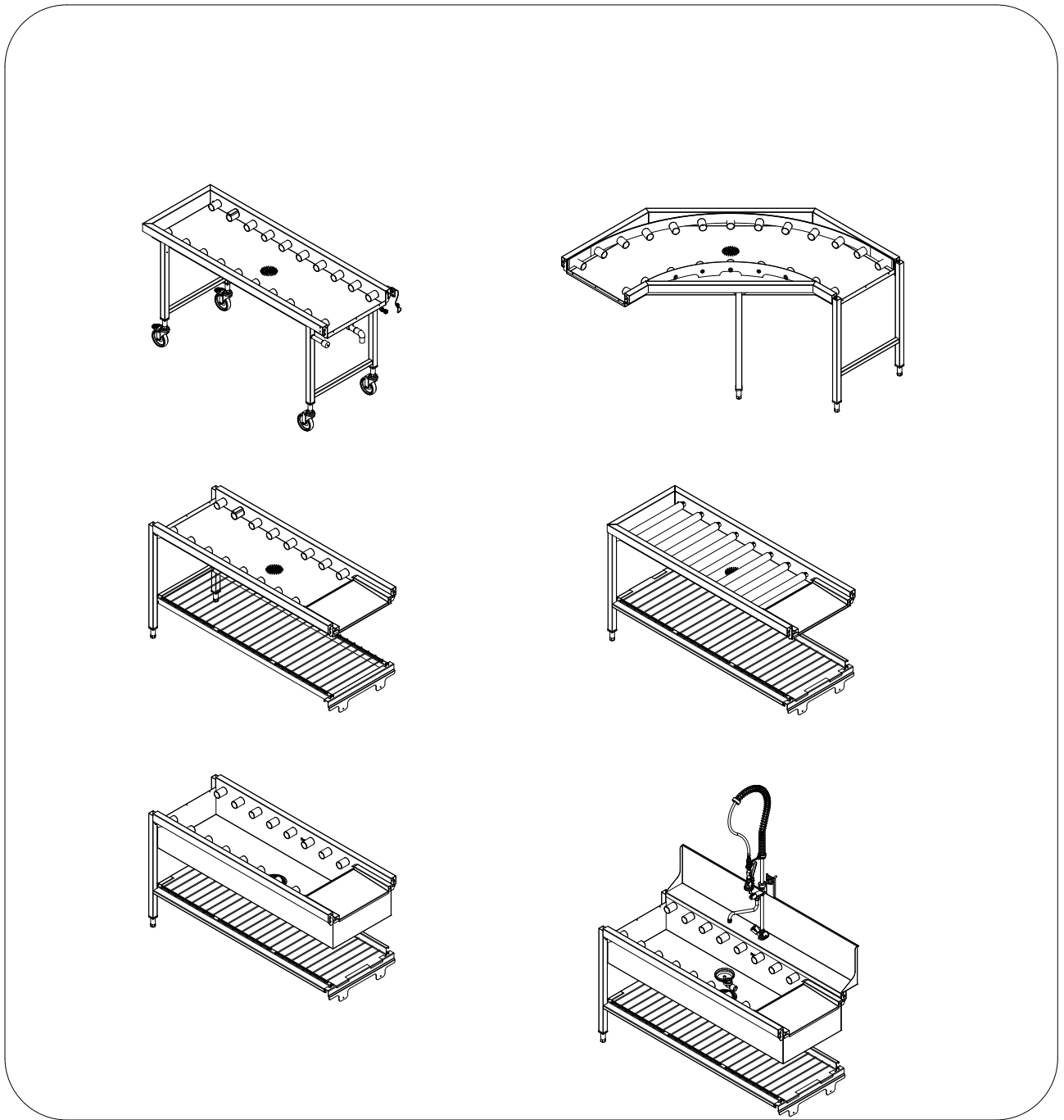

## ROLLER CONVEYOR



- **Roller conveyor, short and long rollers** 3
- **Roller conveyor 90°** 4
- **Mobile Roller conveyor** 5
- **Roller conveyor, deep basin** 6
- **Roller conveyor, deep basin with splash guard** 7
- **Part list** 8-11

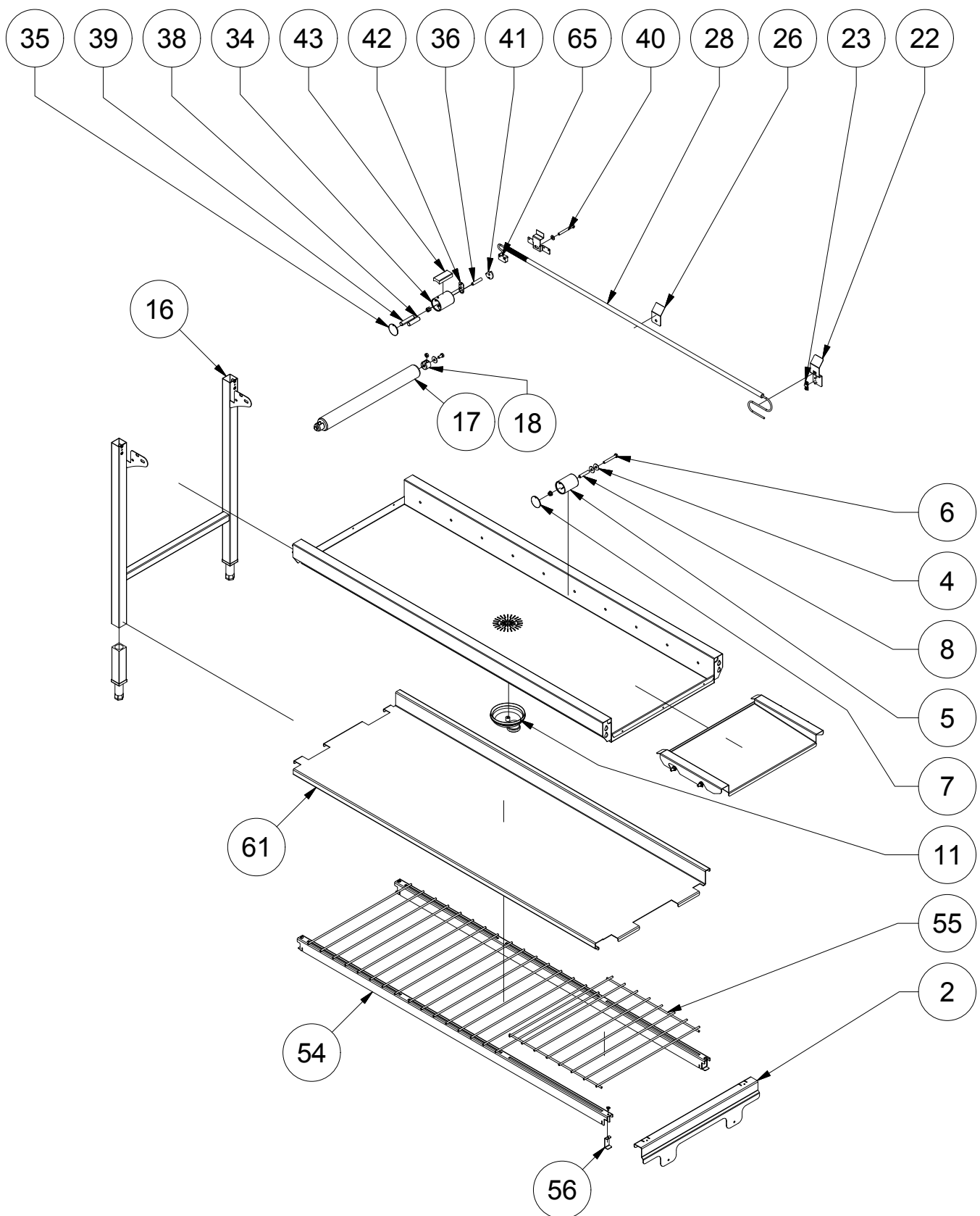

Prod.no.  
 9F86518500 to 9F86519100  
 9F86519200 to 9F86519800  
 9F86300000 to 9F86305100  
 9F86313700 to 9F86314200  
 Edition: 2

Rollerconveyor  
 Rollerconveyor  
 Rollerconveyor  
 Rollerconveyor  
 2017-10

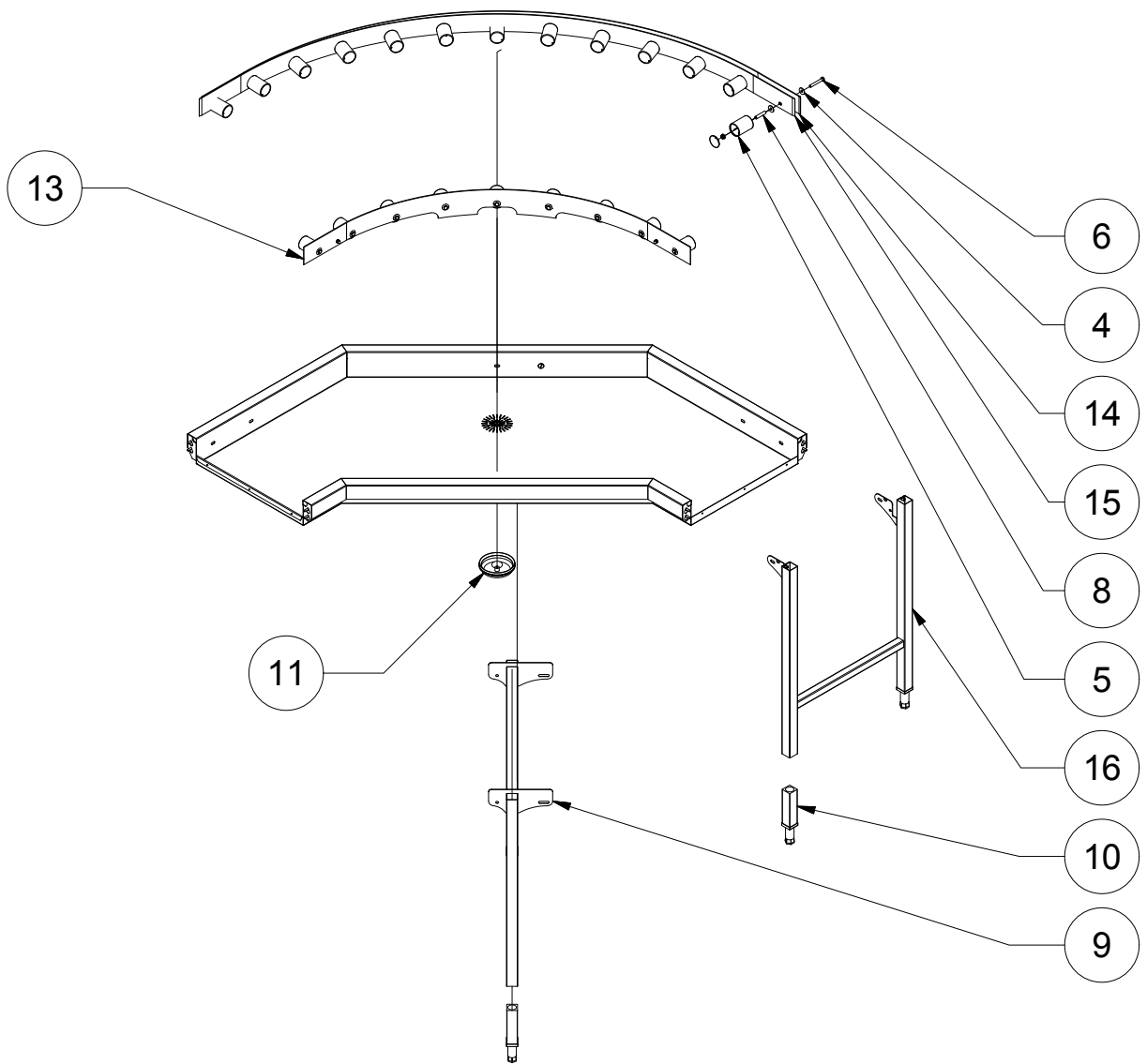

Prod.no.  
 9F86519900

Rollerconveyor curve 90°

Edition: 2

2017-10

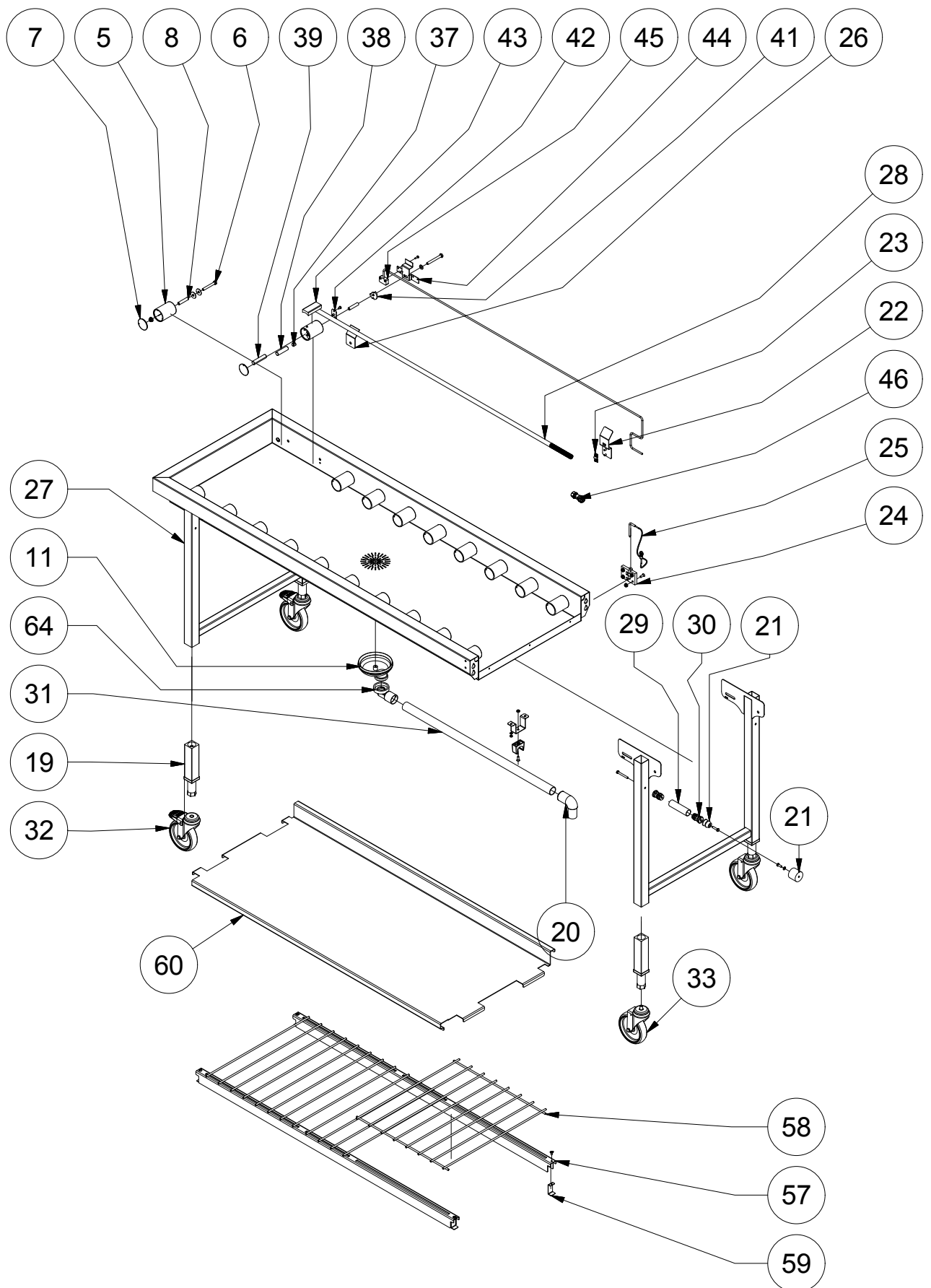

Prod.no.  
 9F86520000 to 9F86520200  
 9F86305200 to 9F86306400

Mobile Rollerconveyor  
 Mobile Rollerconveyor

Edition: 2

2017-10

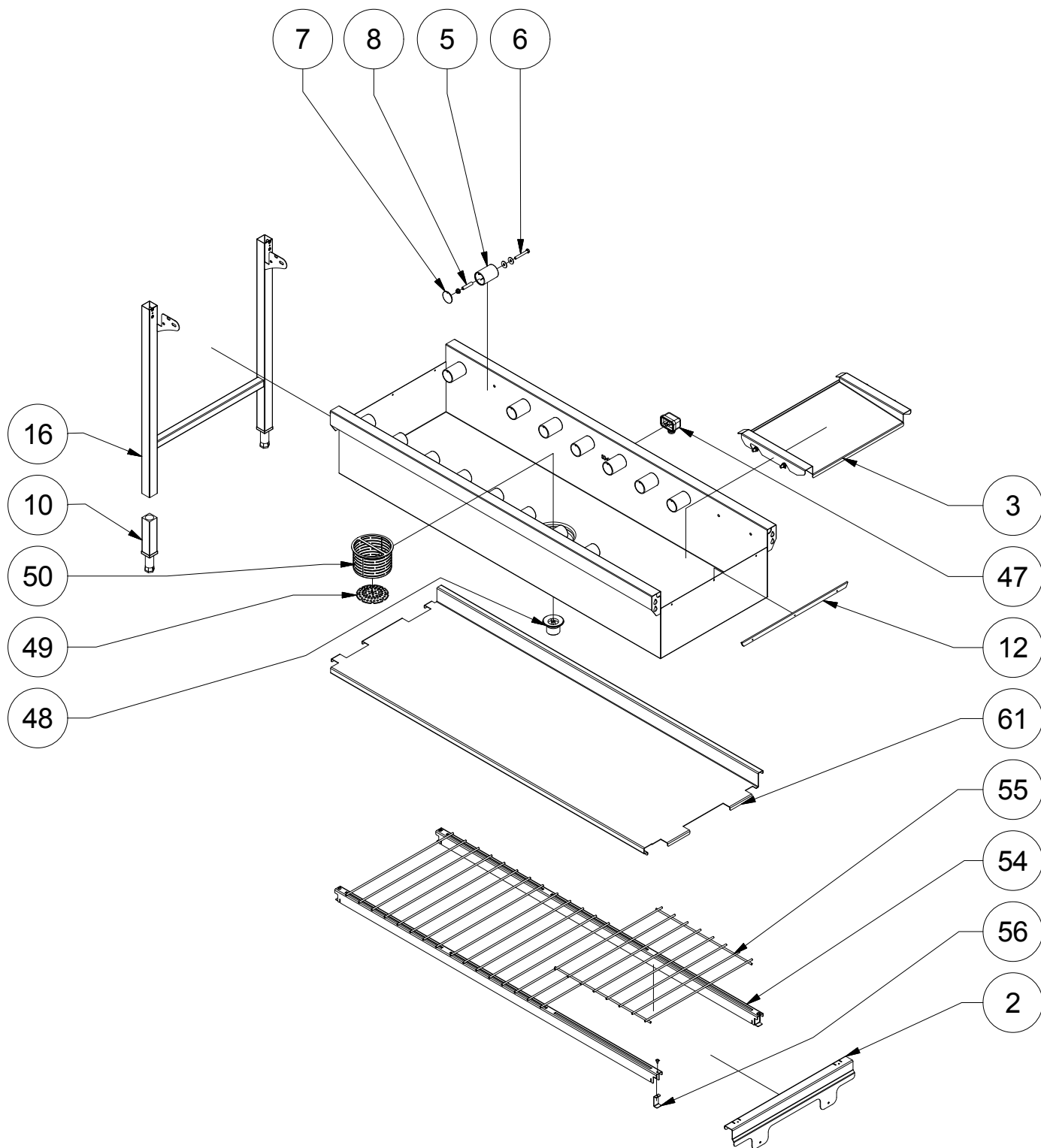

Prod.no.  
 9F86521000 to 9F86521200  
 9F86306500 to 9F86307000

Rollerconveyor, deep basin  
 Rollerconveyor, deep basin

Edition: 2

2017-10

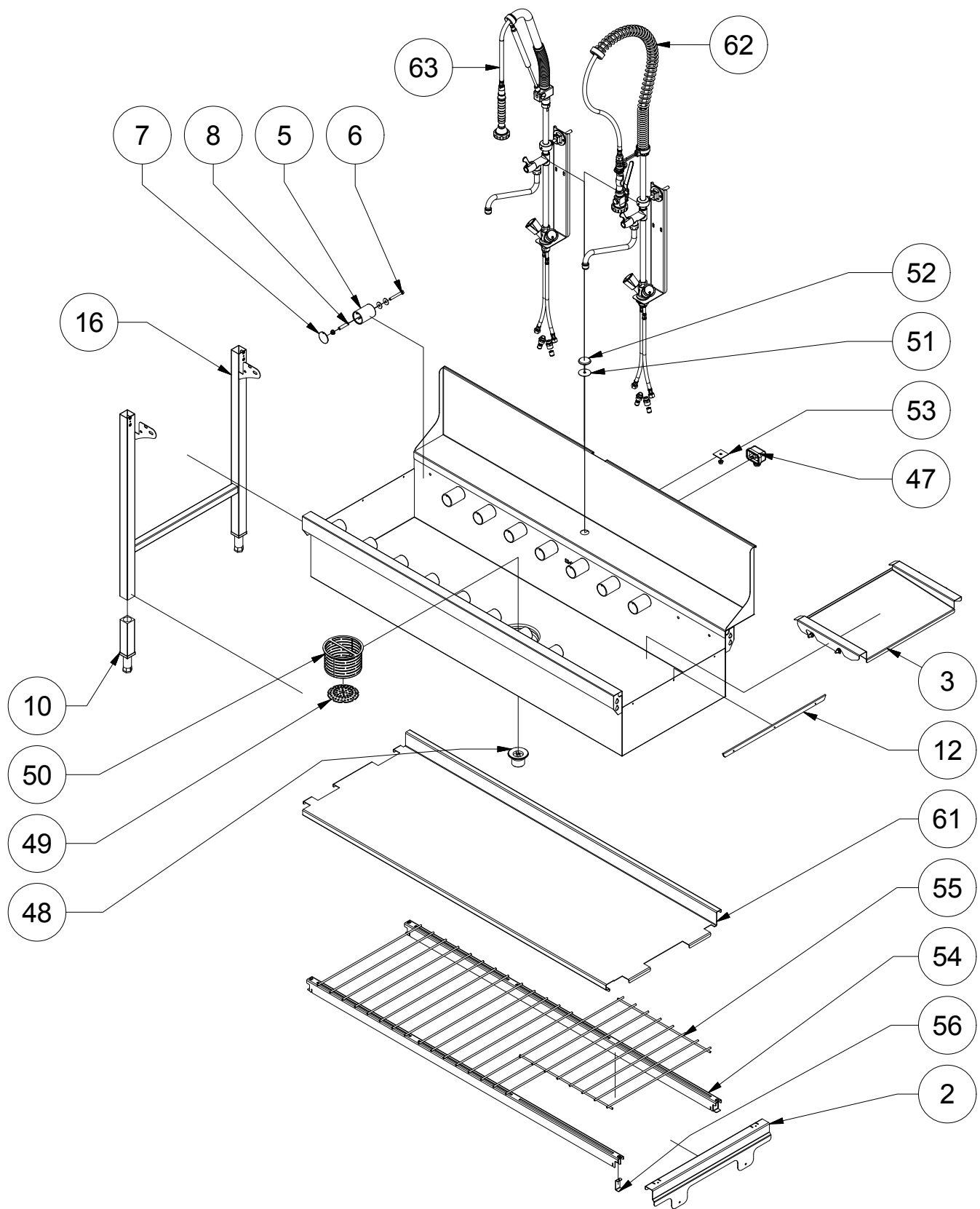

Prod.no.

9F86521300 to 9F86521500 Rollerconveyor, deep basin, splash back

9F86307100 to 9F86307600 Rollerconveyor, deep basin, splash back

Edition: 2

2017-10

41	ST1 16 77-00	Rotation Limit Washer		
40	725 24 65-45	M6S 8x70 Stainless		
39	ST0 66 31-00	Counterweight		
38	ST0 66 31-01	Counterweight		
37	ST0 41 99-00	Magnet Ø12, Neodym		
36	520 27 97-00	Distance		
35	520 31 15-00	Cover		
34	520 30 89-00	Pulley		
33	ST1 14 44-01	Wheel, Ø125		
32	ST1 14 44-00	Wheel with brakes, Ø125		
31	ST8 00 30-00	Plastic tube Ø32		
30	ST1 16 19-00	Plug with threaded hole		
29	ST1 16 18-00	Tube 25x1.5, L=89		
28	552 00 12-01	Protection hose 12B		
27	ST1 15 53-00	Stand, Mobile Conveyor		
26	482 45 60-00	Pipe holder		
25	520 31 40-00	Cotter pin		
24	520 31 39-00	Hinge		
23	552 21 30-00	Screw clamp Ø6		
22	520 30 82-00	Attachment		
21	ST0 39 82-00	Locking device		
20	ST0 39 94-00	Bend 90° Spigot/Socket		
19	ST0 35 79-00	Foot cpl		
18	491 44 43-00	Attachment		
17	491 48 54-02	Long roller		
16	ST1 16 75-00	Stand cpl		
15	ST1 15 94-00	Outer Rim		
14	ST0 48 34-00	Border, outer		
13	ST0 49 77-00	Border, inner		
12	ST0 33 59-00	Snap on		
11	476 80 48-00	Drain pipe connection		
10	ST0 33 76-00	Foot cpl.		
9	ST0 48 35-00	Stand		
8	520 27 97-00	Distance		
7	520 31 15-00	Cover		
6	725 24 63-40	Screw M6S 8x60		
5	520 30 89-00	Pulley		
4	734 11 64-45	Washer 8.4x25 Rfr		
3	9F865253-00	Inclined plate		
2	9F865234-00	Connection bracket		
Pos.	Art. No.	Description	From	To

55	ST1 15 33-00 ST1 15 33-01	Grid shelf, 476 Grid shelf, 220		
54	ST1 15 32-06 ST1 15 32-08 ST1 15 32-11 ST1 15 32-12 ST1 15 32-13 ST1 15 32-14 ST1 15 32-15 ST1 15 32-16 ST1 15 32-17 ST1 15 32-18 ST1 15 32-19 ST1 15 32-20 ST1 15 32-21 ST1 15 32-22 ST1 15 32-23 ST1 15 32-24 ST1 15 32-25 ST1 15 32-26	Rail, Gridshelf, L=600 Rail, Gridshelf, L=800 Rail, Gridshelf, L=1100 Rail, Gridshelf, L=1200 Rail, Gridshelf, L=1300 Rail, Gridshelf, L=1400 Rail, Gridshelf, L=1500 Rail, Gridshelf, L=1600 Rail, Gridshelf, L=1700 Rail, Gridshelf, L=1800 Rail, Gridshelf, L=1900 Rail, Gridshelf, L=2000 Rail, Gridshelf, L=2100 Rail, Gridshelf, L=2200 Rail, Gridshelf, L=2300 Rail, Gridshelf, L=2400 Rail, Gridshelf, L=2500 Rail, Gridshelf, L=2600		
53	482 46 78-00	Washer		
52	482 46 76-00	Cover washer		
51	482 46 77-00	Gasket		
50	ST0 33 90-00	Strainer basket		
49	428 02 89-00	Strainer plate Ø114		
48	476 84 47-00	Drainconnection 1½"		
47	520 05 24-00	Overflow house		
46	ST1 19 55-00	Connector SY21 2-P Male		
45	476 06 64-01	Magnetic switch		
44	ST0 39 99-00	Bracket		
43	ST1 18 23-00	Switch Block		
42	ST1 18 24-00	Bracket for Switch Block		
Pos.	Art. No.	Description	From	To

59	ST0 54 82-00	Locking clamp		
58	ST1 15 33-00	Grid shelf, 476		
57	ST1 16 69-11	Rail, 1145		
	ST1 16 69-12	Rail, 1245		
	ST1 16 69-13	Rail, 1345		
	ST1 16 69-14	Rail, 1445		
	ST1 16 69-15	Rail, 1545		
	ST1 16 69-16	Rail, 1645		
	ST1 16 69-17	Rail, 1745		
	ST1 16 69-18	Rail, 1845		
	ST1 16 69-19	Rail, 1945		
	ST1 16 69-20	Rail, 2045		
	ST1 16 69-21	Rail, 2145		
	ST1 16 69-22	Rail, 2245		
	ST1 16 69-23	Rail, 2345		
	ST1 16 69-24	Rail, 2445		
	ST1 16 69-25	Rail, 2545		
	ST1 16 69-26	Rail,2645		
56	ST0 54 82-00	Locking clamp		
Pos.	Art. No.	Description	From	To

65	476 06 64-02	Magnetic switch NO L=10m		
64	ST1 21 10-00			
63	9F865233-00	Pre-rinse unit Automatic		
62	9F865 231-00	Pre rinse unit		
61	ST1 16 65-06 ST1 16 65-08 ST1 16 65-11 ST1 16 65-12 ST1 16 65-13 ST1 16 65-14 ST1 16 65-15 ST1 16 65-16 ST1 16 65-17 ST1 16 65-18 ST1 16 65-19 ST1 16 65-20 ST1 16 65-21 ST1 16 65-22 ST1 16 65-23 ST1 16 65-24 ST1 16 65-25 ST1 16 65-26	Plain Shelf, L=600 Plain Shelf, L=800 Plain Shelf, L=1100 Plain Shelf, L=1200 Plain Shelf, L=1300 Plain Shelf, L=1400 Plain Shelf, L=1500 Plain Shelf, L=1600 Plain Shelf, L=1700 Plain Shelf, L=1800 Plain Shelf, L=1900 Plain Shelf, L=2000 Plain Shelf, L=2100 Plain Shelf, L=2200 Plain Shelf, L=2300 Plain Shelf, L=2400 Plain Shelf, L=2500 Plain Shelf, L=2600		
60	ST1 16 66-11 ST1 16 66-12 ST1 16 66-13 ST1 16 66-14 ST1 16 66-15 ST1 16 66-16 ST1 16 66-17 ST1 16 66-18 ST1 16 66-19 ST1 16 66-20 ST1 16 66-21 ST1 16 66-22 ST1 16 66-23 ST1 16 66-24 ST1 16 66-25 ST1 16 66-26	Plain Shelf 1145 Plain Shelf 1245 Plain Shelf 1345 Plain Shelf 1445 Plain Shelf 1545 Plain Shelf 1645 Plain Shelf 1745 Plain Shelf 1845 Plain Shelf 1945 Plain Shelf 2045 Plain Shelf 2145 Plain Shelf 2245 Plain Shelf 2345 Plain Shelf 2445 Plain Shelf 2545 Plain Shelf 2645		
Pos.	Art. No.	Description	From	To

