

# Spare part list

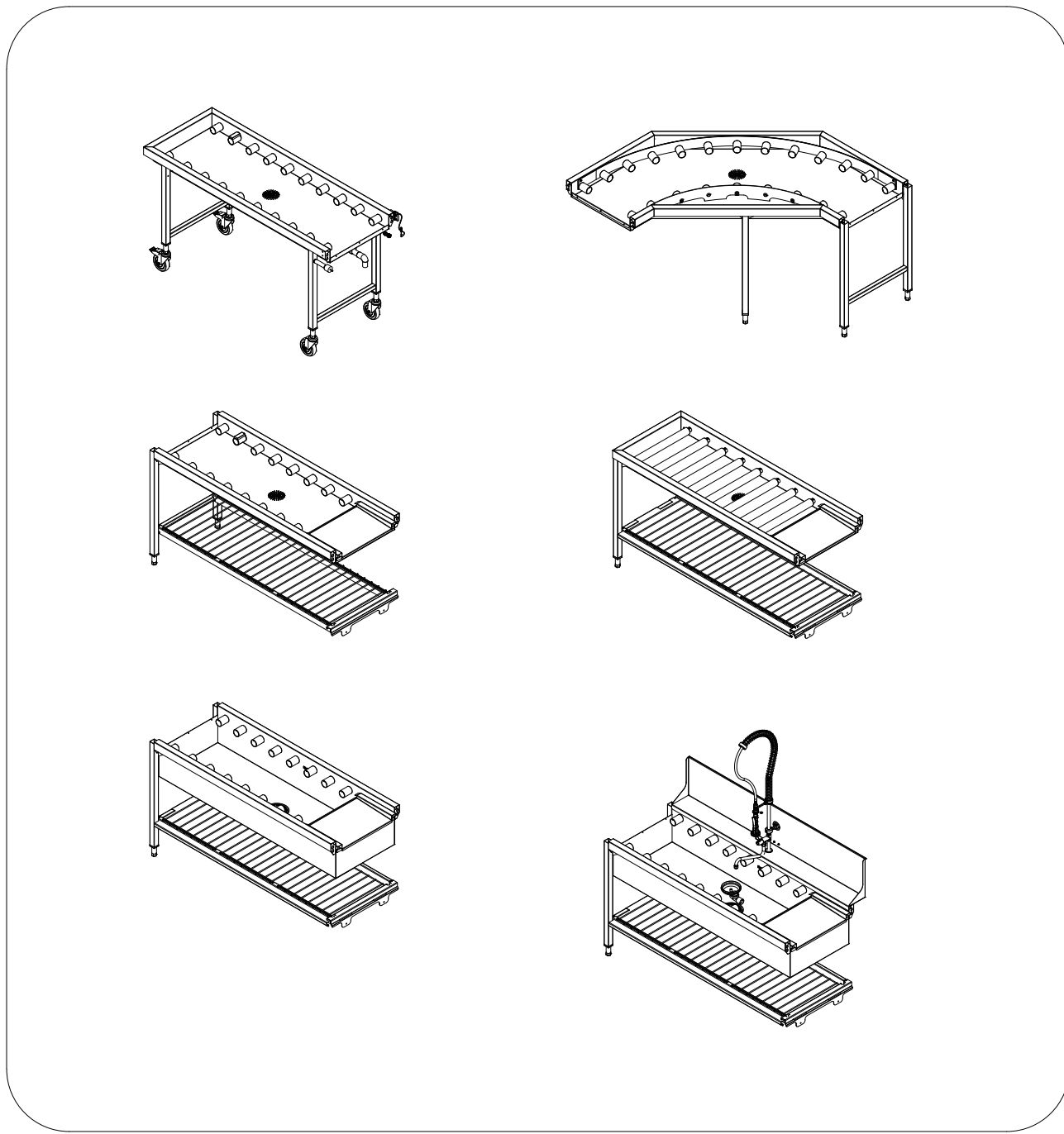

## ROLLER CONVEYOR



• Roller conveyor, short and long rollers	3
• Roller conveyor 90°	4
• Mobile Roller conveyor	5
• Roller conveyor, deep basin	6
• Roller conveyor, deep basin with splash guard	7
• Part list	8-11

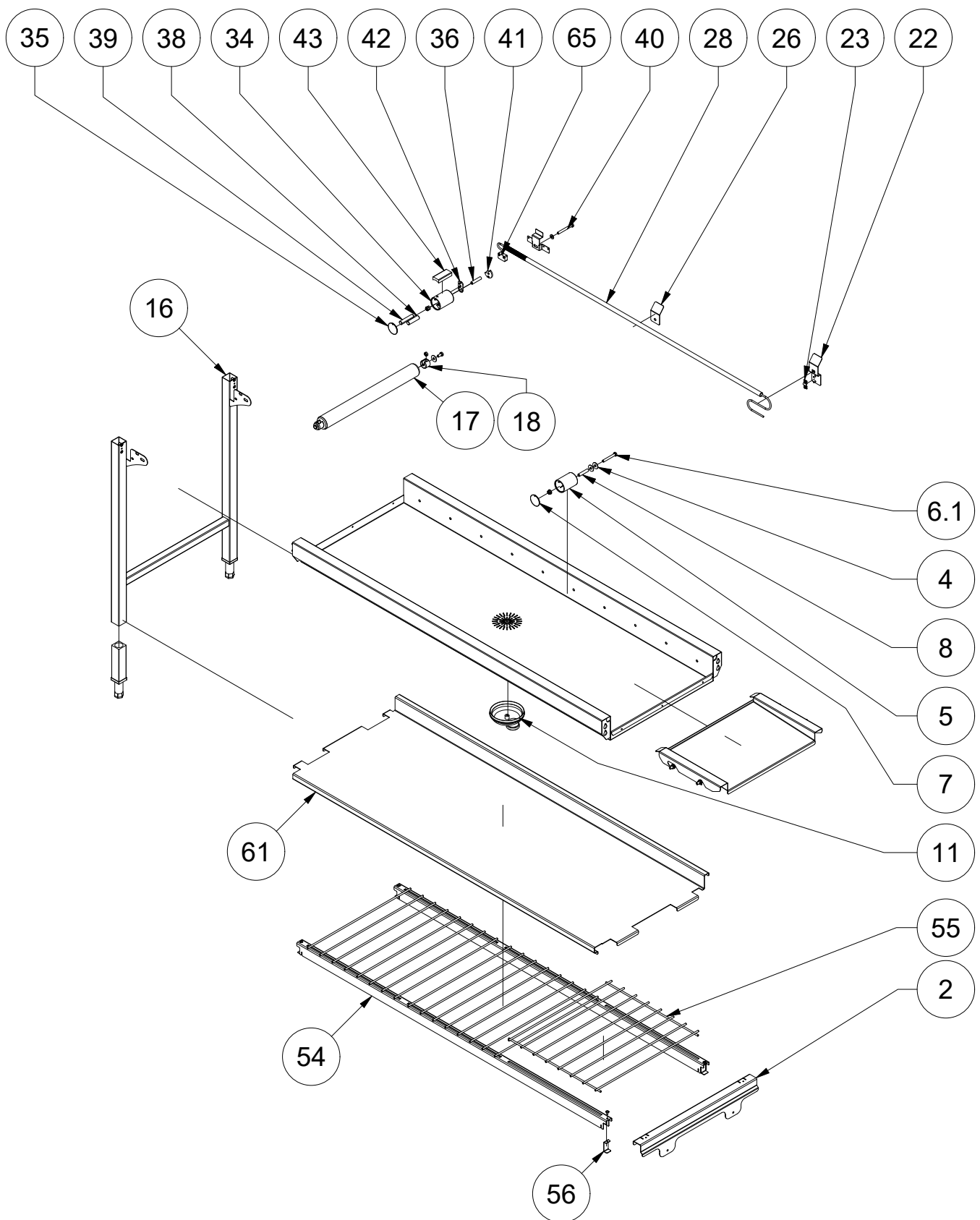

Prod.no.

9F86518500 to 9F86519100

9F86519200 to 9F86519800

9F86300000 to 9F86305100

Rollerconveyor

Rollerconveyor

Rollerconveyor

Edition: 2

2017-10

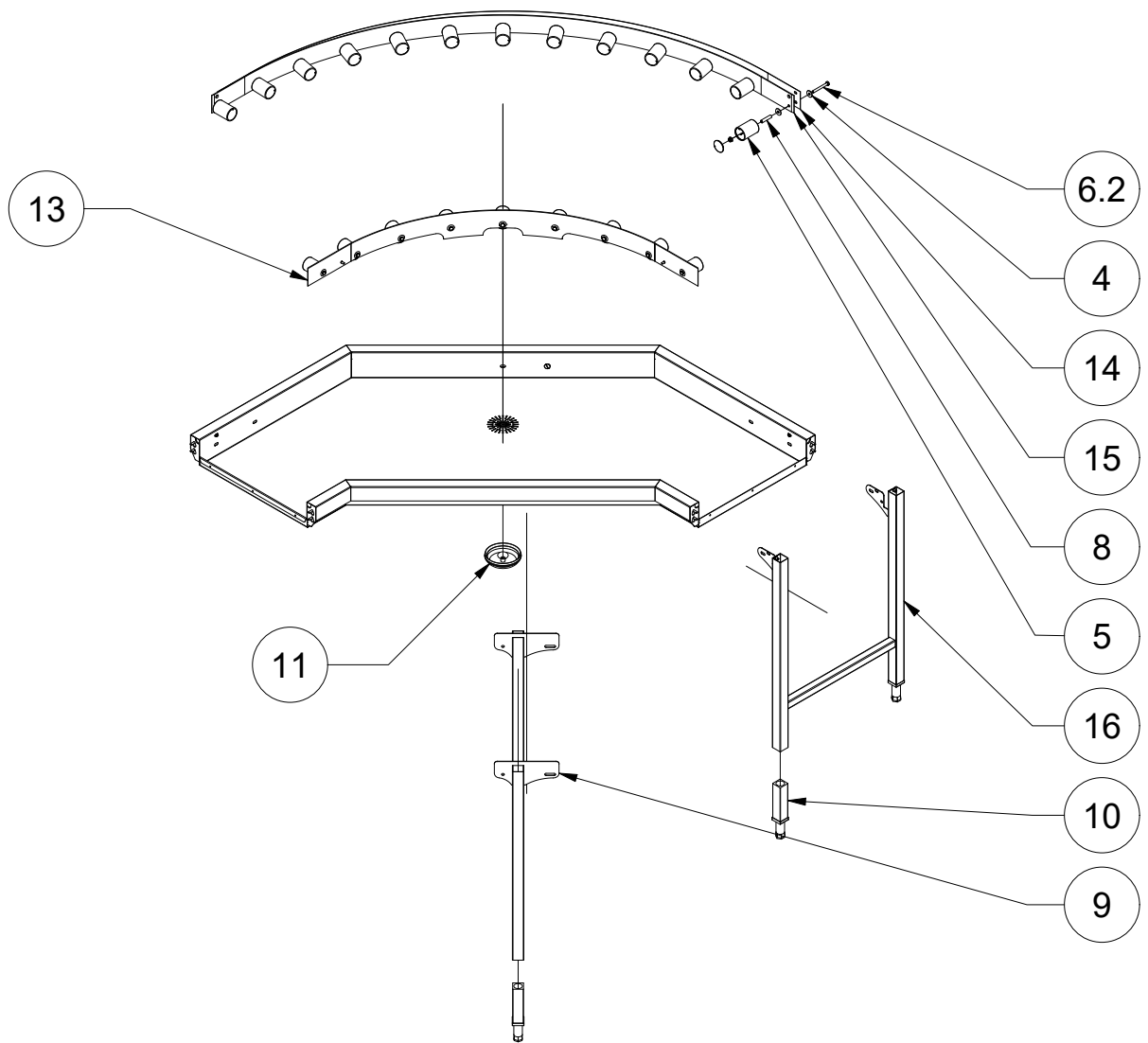

Prod.no.  
9F86519900

Rollerconveyor curve 90°

Edition: 3

2023-02

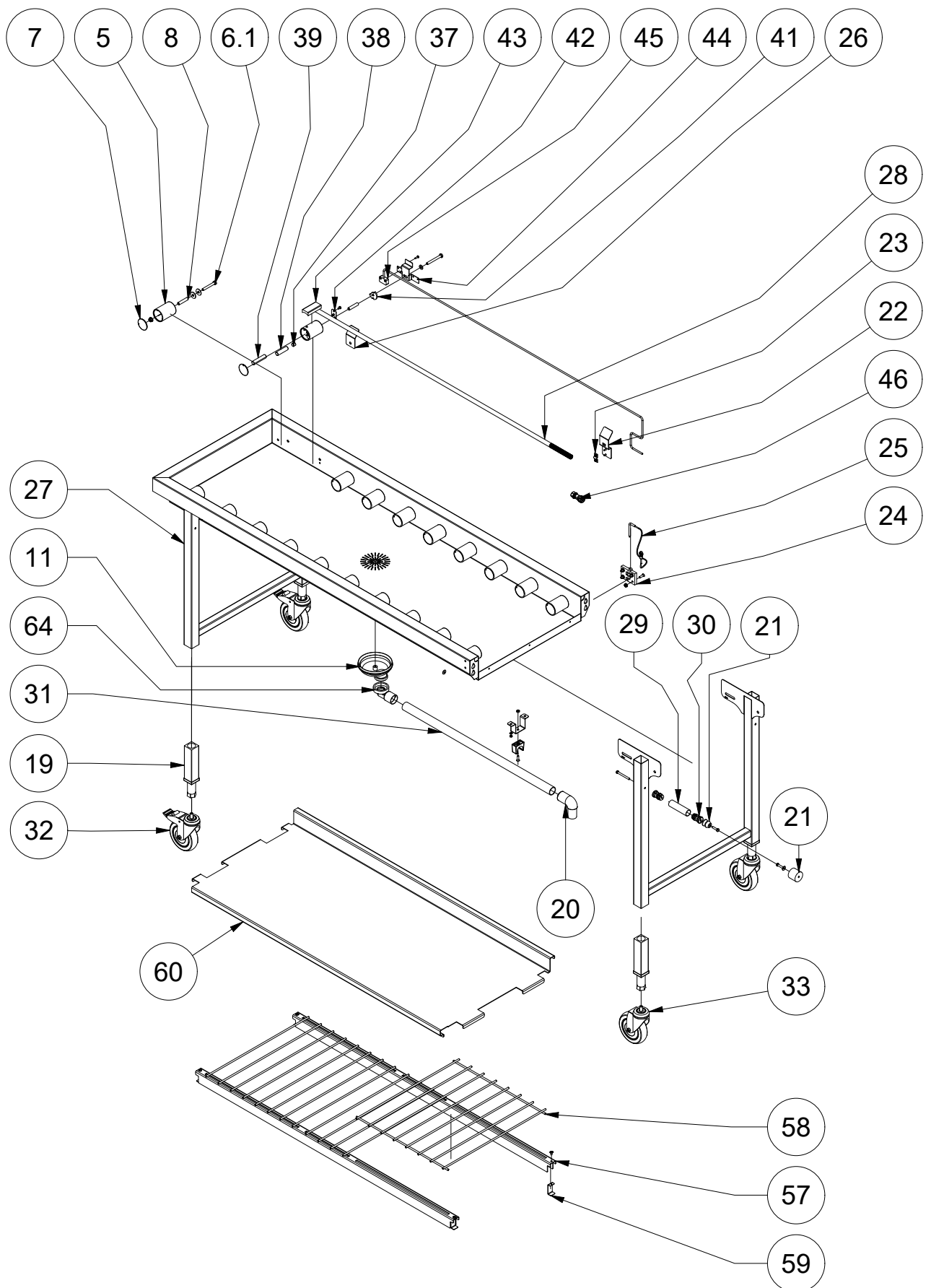

Prod.no.  
 9F86520000 to 9F86520200  
 9F86305200 to 9F86306400

Mobile Rollerconveyor  
 Mobile Rollerconveyor

Edition: 3

2020-02

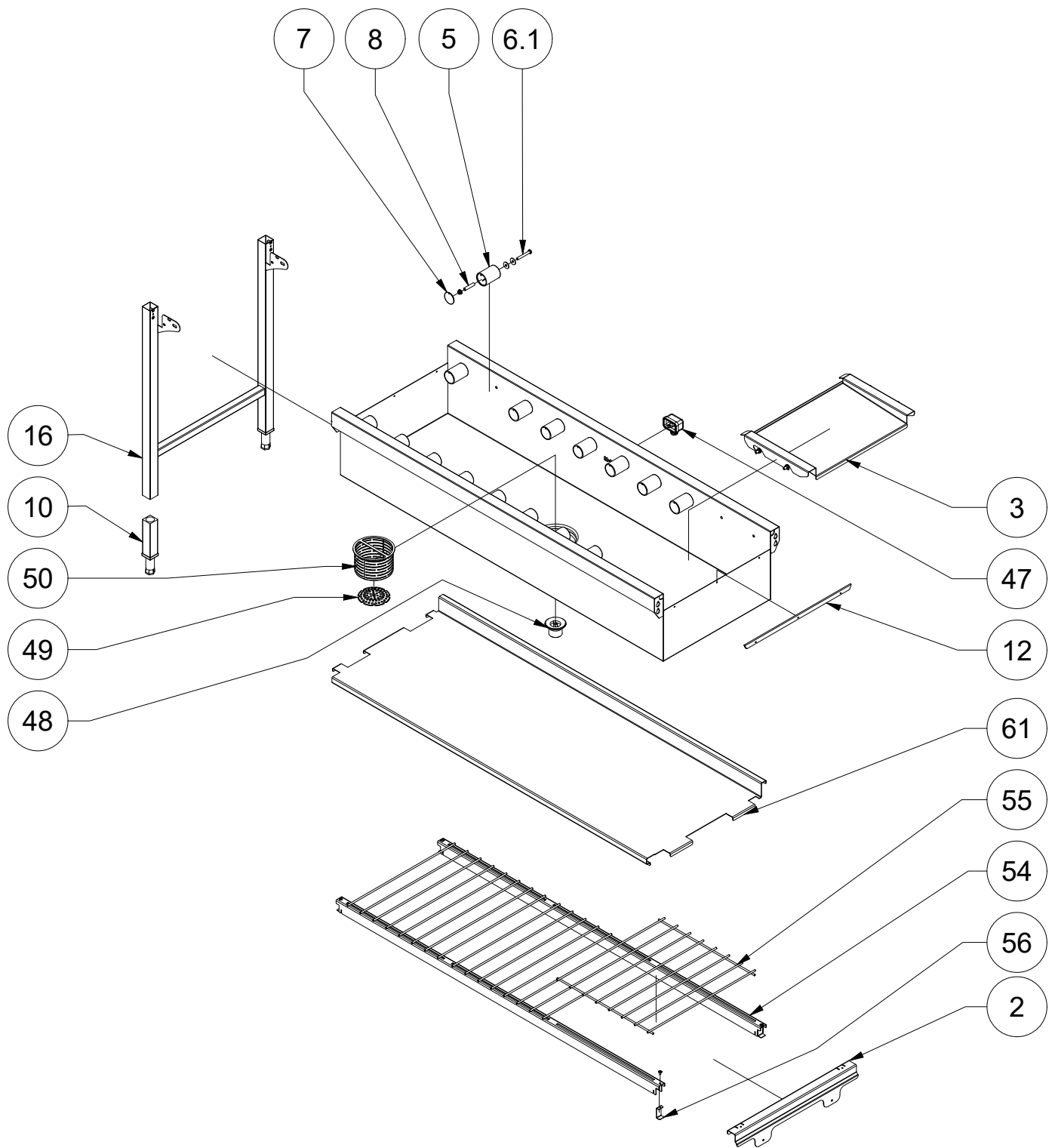

Prod.no.  
 9F86521000 to 9F86521200  
 9F86306500 to 9F86307000

Rollerconveyor, deep basin  
 Rollerconveyor, deep basin

Edition: 2

2017-10



39	ST0 66 31-00	Counterweight		
38	ST0 66 31-01	Counterweight		
37	ST0 41 99-00	Magnet Ø12, Neodym		
36	520 27 97-00	Distance		
35	520 31 15-00	Cover		
34	520 30 89-00	Pulley		
33	ST1 14 44-01 ST1 29 17-01	Swivel castor Ø125	2020 week 6	2020 week 5
32	ST1 14 44-00 ST1 29 17-00	Swivel castor Ø125 with total lock	2020 week 6	2020 week 5
31	ST8 00 30-00	Plastic tube Ø32		
30	ST1 16 19-00	Plug with threaded hole		
29	ST1 16 18-00	Tube 25x1.5, L=89		
28	552 00 12-01	Protection hose 12B		
27	ST0 33 73-00	Stand cpl		
18	491 44 43-00	Attachment		
17	491 48 54-02	Long roller		
26	482 45 60-00	Pipe holder		
25	520 31 40-00	Cotter pin		
24	520 31 39-00	Hinge		
23	552 21 30-00	Screw clamp Ø6		
22	520 30 82-00	Attachment		
21	ST0 39 82-00	Locking device		
20	ST0 39 94-00	Bend 90° Spigot/Socket		
19	ST0 35 79-00	Foot cpl		
16	ST1 16 75-00	Stand cpl		
15	ST1 15 94-00	Outer Rim		
14	ST1 22 67-00	Outer Rim Reinforcement		
13	ST0 49 77-00	Border, inner		
12	ST0 33 59-00	Snap on		
11	476 80 48-00	Drain pipe connection		
10	ST0 33 76-00	Foot cpl.		
9	ST0 48 35-00	Stand		
8	520 27 97-00	Distance		
7	520 31 15-00	Cover		
6.2	725 24 65-45	Screw M6S 8x70		
6.1	725 24 63-40	Screw M6S 8x60		
5	520 30 89-00	Pulley		
4	734 11 64-45	Washer 8.4x25 Rfr		
3	9F865253-00	Inclined plate		
2	9F865234-00	Connection bracket		
Pos.	Art. No.	Description	From	To

55	ST1 15 33-00 ST1 15 33-01	Grid shelf, 476 Grid shelf, 220		
54	ST1 15 32-06 ST1 15 32-08 ST1 15 32-11 ST1 15 32-12 ST1 15 32-13 ST1 15 32-14 ST1 15 32-15 ST1 15 32-16 ST1 15 32-17 ST1 15 32-18 ST1 15 32-19 ST1 15 32-20 ST1 15 32-21 ST1 15 32-22 ST1 15 32-23 ST1 15 32-24 ST1 15 32-25 ST1 15 32-26	Rail, Gridshelf, L=600 Rail, Gridshelf, L=800 Rail, Gridshelf, L=1100 Rail, Gridshelf, L=1200 Rail, Gridshelf, L=1300 Rail, Gridshelf, L=1400 Rail, Gridshelf, L=1500 Rail, Gridshelf, L=1600 Rail, Gridshelf, L=1700 Rail, Gridshelf, L=1800 Rail, Gridshelf, L=1900 Rail, Gridshelf, L=2000 Rail, Gridshelf, L=2100 Rail, Gridshelf, L=2200 Rail, Gridshelf, L=2300 Rail, Gridshelf, L=2400 Rail, Gridshelf, L=2500 Rail, Gridshelf, L=2600		
53	482 46 78-00	Washer		
52	482 46 76-00	Cover washer		
51	482 46 77-00	Gasket		
50	ST0 33 90-00	Strainer basket		
49	428 02 89-00	Strainer plate Ø114		
48	476 84 47-00	Drainconnection 1½"		
47	520 05 24-00	Overflow house		
46	ST1 19 55-00	Connector SY21 2-P Male		
45	476 06 64-01	Magnetic switch		
44	ST0 39 99-00	Bracket		
43	ST1 18 23-00	Switch Block		
42	ST1 18 24-00	Bracket for Switch Block		
41	ST1 16 77-00	Rotation Limit Washer		
40	725 24 65-45	Screw M6S 8x70		
Pos.	Art. No.	Description	From	To

60	ST1 16 66-11 ST1 16 66-12 ST1 16 66-13 ST1 16 66-14 ST1 16 66-15 ST1 16 66-16 ST1 16 66-17 ST1 16 66-18 ST1 16 66-19 ST1 16 66-20 ST1 16 66-21 ST1 16 66-22 ST1 16 66-23 ST1 16 66-24 ST1 16 66-25 ST1 16 66-26	Plain Shelf 1145 Plain Shelf 1245 Plain Shelf 1345 Plain Shelf 1445 Plain Shelf 1545 Plain Shelf 1645 Plain Shelf 1745 Plain Shelf 1845 Plain Shelf 1945 Plain Shelf 2045 Plain Shelf 2145 Plain Shelf 2245 Plain Shelf 2345 Plain Shelf 2445 Plain Shelf 2545 Plain Shelf 2645		
59	ST0 54 82-00	Locking clamp		
58	ST1 15 33-00	Grid shelf, 476		
57	ST1 16 69-11 ST1 16 69-12 ST1 16 69-13 ST1 16 69-14 ST1 16 69-15 ST1 16 69-16 ST1 16 69-17 ST1 16 69-18 ST1 16 69-19 ST1 16 69-20 ST1 16 69-21 ST1 16 69-22 ST1 16 69-23 ST1 16 69-24 ST1 16 69-25 ST1 16 69-26	Rail, 1145 Rail, 1245 Rail, 1345 Rail, 1445 Rail, 1545 Rail, 1645 Rail, 1745 Rail, 1845 Rail, 1945 Rail, 2045 Rail, 2145 Rail, 2245 Rail, 2345 Rail, 2445 Rail, 2545 Rail,2645		
56	ST0 54 82-00	Locking clamp		
Pos.	Art. No.	Description	From	To

65	476 06 64-02	Magnetic switch NO L=10m		
64	ST1 21 10-00	Drain pipe 90°, 32mm x G32/G40		
63	9F865233-00	Pre-rinse unit Automatic		
62	9F865 231-00	Pre rinse unit		
61	ST1 16 65-06	Plain Shelf, L=600		
	ST1 16 65-08	Plain Shelf, L=800		
	ST1 16 65-11	Plain Shelf, L=1100		
	ST1 16 65-12	Plain Shelf, L=1200		
	ST1 16 65-13	Plain Shelf, L=1300		
	ST1 16 65-14	Plain Shelf, L=1400		
	ST1 16 65-15	Plain Shelf, L=1500		
	ST1 16 65-16	Plain Shelf, L=1600		
	ST1 16 65-17	Plain Shelf, L=1700		
	ST1 16 65-18	Plain Shelf, L=1800		
	ST1 16 65-19	Plain Shelf, L=1900		
	ST1 16 65-20	Plain Shelf, L=2000		
	ST1 16 65-21	Plain Shelf, L=2100		
	ST1 16 65-22	Plain Shelf, L=2200		
	ST1 16 65-23	Plain Shelf, L=2300		
	ST1 16 65-24	Plain Shelf, L=2400		
	ST1 16 65-25	Plain Shelf, L=2500		
	ST1 16 65-26	Plain Shelf, L=2600		
Pos.	Art. No.	Description	From	To

